



The Leopold® Clari-DAF® LT System

The Leopold® Clari-DAF® LT (Lagoon Treatment) system is a clarification technology for the removal of algae, colloidal and suspended solids, precipitated dissolved solids, and BOD (Biochemical Oxygen Demand) associated with suspended solids from wastewater lagoon treatment systems. It is a proven, highly effective technology for providing consistent effluent water quality and lowering your total cost of operation.

Helps Meet Effluent Permit Requirements

Installing a Leopold® Clari-DAF® LT system after a wastewater lagoon settlement pond and before discharge to creeks, streams, rivers, or lakes can help wastewater treatment plants stay within effluent permit requirements by removing low-density solids that have not settled out. The Clari-DAF® LT system can help wastewater plants stay within permit requirements during summer months when seasonal algae blooms can lead to regulatory issues.

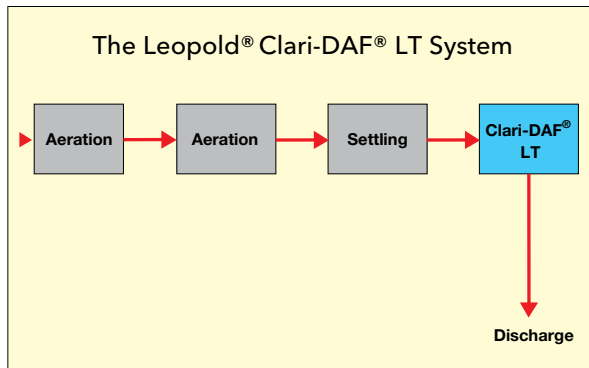

Additional Benefits

Creating hundreds of millions of microbubbles of air to float suspended low-density particles out of the effluent, the Clari-DAF® LT system increases the dissolved oxygen content in the discharged water. By adding small amounts of iron or aluminum coagulants, the Clari-DAF® LT system can effectively remove phosphates, too.

Results Prove the Clari-DAF® LT System Effective

Prior to the installation of a Clari-DAF® LT system as the final process step at a 0.4 MGD wastewater treatment plant in Johnstown, Colorado, the average effluent TSS achieved by sedimentation was 25 ppm (versus an average 195 ppm influent TSS) and the average effluent BOD achieved by sedimentation was 9.6 ppm (versus an average 227 ppm influent BOD). This was within the plant's U.S. EPA National Pollutant Discharge Elimination System (NPDES) permit for effluent of <75 ppm TSS and <30 ppm BOD. However, the plant routinely exceeded its permit limits due to algae bloom in the summer.

After installation of a Clari-DAF® LT system to handle the algae and additional TSS and BOD from a moving bed biofilm reactor that had been installed to remove ammonia, not only were permit excursions due to algae growth eliminated, but also further reductions in TSS and BOD resulted. Average TSS dropped from 25 to 8.1 ppm and average BOD dropped from 9.6 to 1.2 ppm. In addition, the coli-forms previously leaving the settling pond decreased from 5,000 cfu/100 ml to 250 cfu/100 ml leaving the Clari-DAF® LT system.

Potential to Process Increased Flow-Through

The Johnstown, Colorado wastewater treatment plant with the Clari-DAF® LT system installed is presently operating at 4 gpm/sf. But pilot tests show that it can operate at 8 gpm/sf. This means that the plant can handle increased flow-through without having to add additional capacity—a capital cost savings.

Improved Sludge Solids Lowers Cost

With the Clari-DAF® LT system, the solids content that can be achieved is 3% to 5% compared to 0.5% to 1% for gravity sedimentation. This results in increasing the efficiency of sludge handling equipment and reduction in the cost for sludge processing. Dewatering can occur without additional thickening, eliminating expensive sludge thickeners. There is less volume of sludge to handle, less chemical conditioning, less time to dewater, and lower energy costs. Because cake solids are higher, disposal costs are reduced.



This floating sludge blanket is a mass of solids created by floating low-density suspended particles that have not settled out in the wastewater lagoon.



The next step for this sludge produced by a Clari-DAF® LT system is dewatering where higher cake solids result in lower disposal cost.

How the Leopold® Clari-DAF® LT System Can Lower the Overall Cost of Wastewater Lagoon Treatment

Improved solids handling	High percentage sludge solids for lower chemical cost, less time to dewater, lower energy cost Higher cakes solids for lower disposal cost
High loading rate	Handles increased flow-through without additional capital expense

Call Leopold® to learn more about how the Clari-DAF® LT system can lower your total cost of wastewater lagoon treatment.



Xylem, Inc.
227 South Division Street
Zelienople, PA 16063
Telephone: (724) 452-6300
Fax: (724) 452-1377
www.xyleminc.com