

SCUBA* SERIES

CLOSE-COUPLED SUBMERSIBLE PUMPS

APPLICATIONS

- Water supply from rain water tanks or reservoirs, 6" wells, basins and watercourses.
- Sprinkler systems.
- Pressure boosting with pump inserted directly in tank or well, to avoid suction problems and noise.

SPECIFICATIONS

- **Delivery:** up to **7,5 m³/h.**
- **Head:** up to **75,5 m.**
- **Maximum** pump overall **diameter: 128 mm.**
- **Maximum immersion depth: 20 m.**
- **Maximum** permissible quantity of **suspended sand: 25 g/m³.**
- **Passage of solids** up to **2.5 mm.**
- **Delivery port: Rp 1 1/4".**
- **Rated motor power: 0.55 to 1.1 kW.**
- **Single-phase motor:** 220-240 V, 50 Hz, built-in automatic reset overload protection. A control box with 2-pole switch and capacitor is available on request.
- **Three-phase motor:** 380-415 V, 50 Hz; overload protection to be provided by user and installed in the control box (see control box section).
- Maximum supply voltage variations: $\pm 5\%$
- Class F insulation.
- Can also operate in **horizontal position.**
- Maximum number of **starts per hour**, at regular intervals:
 - 25** for motors up to **0.9 kW.**
 - 20** for motors **1.1 kW** and up.
- Maximum temperature of water in contact with the motor: 40°C (continuous use).

CONSTRUCTION FEATURES

- Close-coupled, multiple-impeller submersible electric pump.
The liquid end is located under the motor, which is cooled by the pumped liquid.

* Named SC for UK market.



• Dry motor

The electric motor is protected by a double seal with an oil chamber.

• Sealing system

The silicon carbide mechanical seal, highly resistant to abrasion and wear, and the lip seal, continuously lubricated thanks to the special design of the oil chamber, ensure the absolute tightness of the motor seal. In the event of dry running, the sealing system will not be damaged and the motor will not suffer from infiltration.

The oil used complies with standards concerning oils in contact with foodstuffs and satisfies the purity requirements established by the annex to G.U. no. 104 of 20/04/1973; it also complies with FDA (FOOD AND DRUG ADMINISTRATION) standards.

- Single-phase models with float (CG) are also available

TABLE OF MATERIALS

PART	MATERIAL
Outer sleeve, Upper support, Suction screen, Shaft, Screws and tie-rods, Diffusers	STAINLESS STEEL AISI 304 - DIN 1.4301
Impeller	NORYL
Upper cap, Mechanical seal housing	TECHNOPOLYMER
Lower bearing support	DIE-CAST ALUMINIUM
Lower bearing	SPECIAL RUBBER
Elastomers	NITRILE RUBBER (NBR)
Mechanical seal	SILICON CARBIDE/ SILICON CARBIDE

All the nitrile rubber, polyurethane and polycarbonate components are suitable for usage with foodstuffs and comply with FDA specification (the Food and Drug Administration is the US agency for the safeguard of public health).

SCUBA* SERIES
OPERATING CHARACTERISTICS AT 2850 rpm 50 Hz

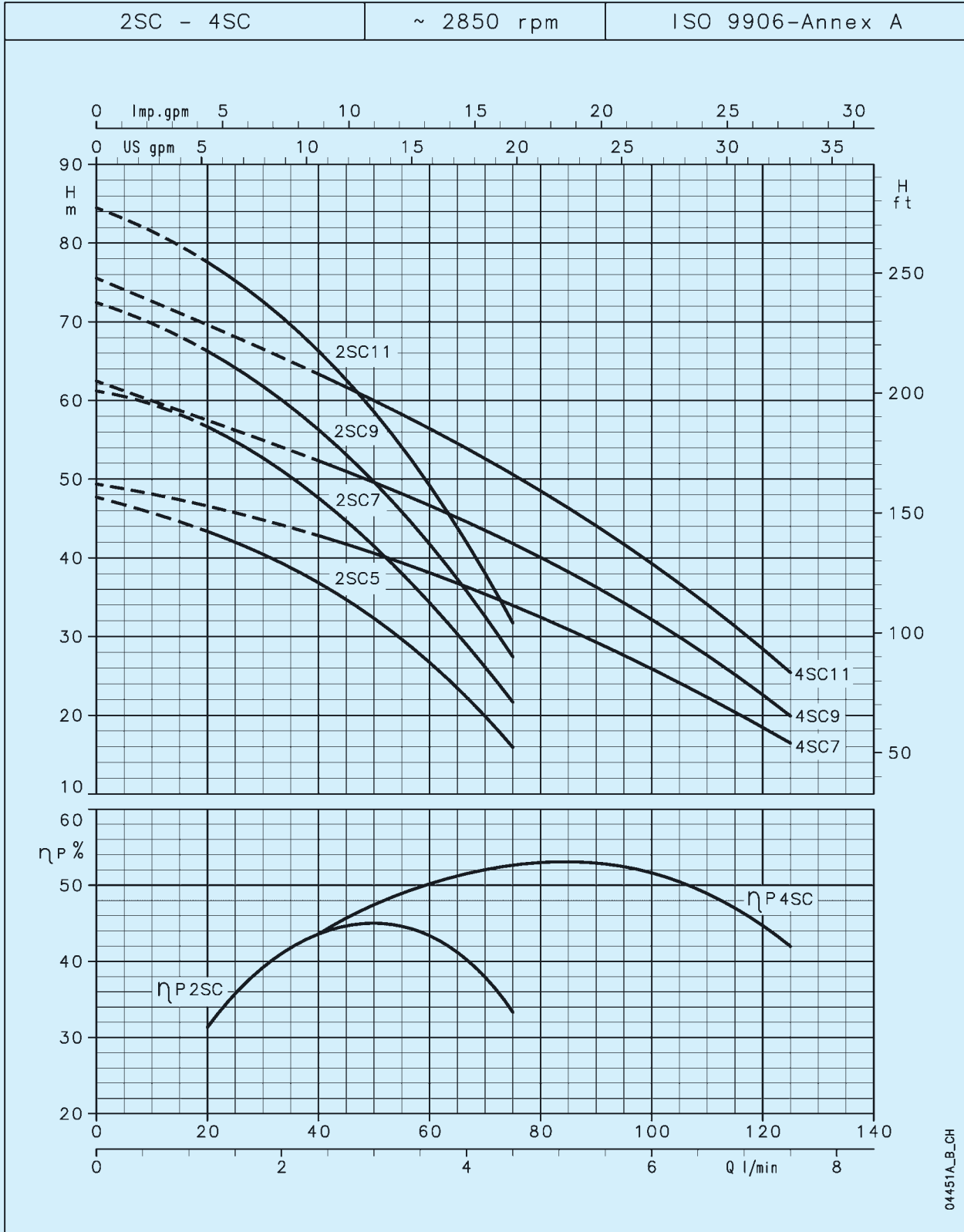

SCUBA*

These performances are valid for liquids with density $\rho = 1.0 \text{ kg/dm}^3$ and kinematic viscosity $\gamma = 1 \text{ mm}^2/\text{sec}$.
 * Named SC for UK market.

DIMENSIONS AND WEIGHTS

PUMP TYPE	DIMENSIONS	
	L mm	WEIGHT kg
2SC5	496	13.5
2SC7	536	15
2SC9	561	16
2SC11	606	18
4SC7	511	14.5
4SC9	536	15.5
4SC11	581	17.5
2SC5T	496	13.5
2SC7T	536	15
2SC9T	561	16
2SC11T	606	18
4SC7T	511	14.5
4SC9T	536	15.5
4SC11T	581	17.5

Singlephase version with float switch available (SCUBA CG)

scuba-2p50_a_td

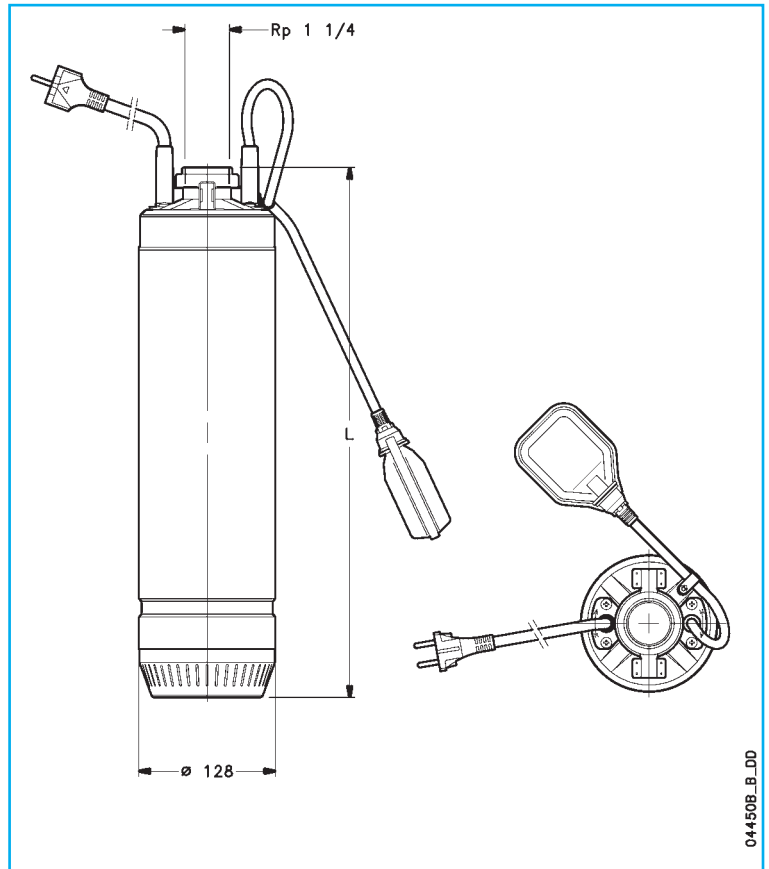

044508_B_DD

SCUBA* SERIES HYDRAULIC PERFORMANCE TABLE AT 2850 rpm

PUMP TYPE	RATED POWER		Q = DELIVERY													
			l/min	0	20	30	40	50	60	75	80	100	125			
			m ³ /h	0	1.2	1.8	2.4	3	3.6	4.5	4.8	6	7.5			
		H = TOTAL HEAD METERS COLUMN OF WATER														
	kW	HP														
2SC5(T)	0.55	0.75	47.7	43.4	40.5	36.8	32.3	26.7	15.9							
2SC7(T)	0.75	1	61.2	56.7	52.7	47.6	41.5	34.3	21.7							
2SC9(T)	0.9	1.2	72.4	66.3	61.8	56.3	49.6	41.8	27.4							
2SC11(T)	1.1	1.5	84.5	77.6	72.6	66.3	58.6	49.2	31.7							
4SC7(T)	0.75	1	49.4			42.8	40.6	38.1	34.0	32.5	25.9	16.5				
4SC9(T)	0.9	1.2	62.5			52.3	49.6	46.7	41.8	40.1	32.2	19.9				
4SC11(T)	1.1	1.5	75.5			63.4	60.0	56.4	50.6	48.5	39.3	25.4				

scuba-2p50_a_te

PUMP TYPE	INPUT POWER*	INPUT CURRENT*	CAPACITOR
	SINGLE-PHASE	220-240 V	
	kW	A	µF / 450 V
2SC5	0.93	4.37	16
2SC7	1.15	5.19	25
2SC9	1.32	5.88	25
2SC11	1.63	7.25	30
4SC7	1.18	5.28	25
4SC9	1.38	6.17	25
4SC11	1.76	7.85	30

* Maximum value in specified range

PUMP TYPE	INPUT POWER*	INPUT CURRENT*	INPUT CURRENT*
	THREE-PHASE	220-240 V	380-415 V
	kW	A	A
2SC5T	0.86	2.81	1.62
2SC7T	1.09	4.12	2.38
2SC9T	1.27	4.40	2.54
2SC11T	1.45	4.68	2.70
4SC7T	1.12	4.16	2.40
4SC9T	1.33	4.50	2.60
4SC11T	1.59	4.94	2.85

scuba-2p50_a_te

SCUBA*