



Technical brochure 50 Hz

Flygt submersible pumps and mixers



Flygt



ITT Industries
Engineered for life

CONTENTS

A guide to performance data	3
B-PUMPS	4
C-PUMPS Small and medium size	9
C- AND R-PUMPS Large size	23
D-PUMPS	29
F-PUMPS	41
H-PUMPS 3000-series	45
H-PUMPS 5500-series	48
L-PUMPS	54
M-PUMPS	62
MIXERS	67
N-PUMPS	70
PROPELLER PUMPS 4600-series	82
PROPELLER PUMPS 7000-series	86
B-PUMPS In bronze and stainless steel	93
C-PUMPS In stainless steel	94
D-PUMPS In bronze and stainless steel	99
EXPLOSION PROOF PUMPS AND MIXERS	102
DIMENSIONS	102

THIS IS WHAT OUR CURVES, TABLES AND CHARTS SHOW YOU.

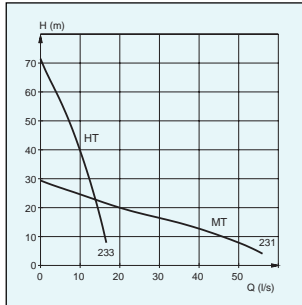

B pumps

The curves are the specified performance for the impeller selected.

The values shown are for a BS 2125 pump. Impeller characteristics are coded as follows:

LT=Low head. MT=Medium head. HT=High head. SH=Super High head.

□ = optimal duty point.

Technical data	MT	HT
Impeller code	231	233
Phase	3~	3~
Speed of rotation	2875 rpm	2875 rpm
Output power	8 kW	8 kW
Input power	9,5 kW	9,5 kW
Weight	77 kg	80 kg

C, D, F, L, M, N and H pumps

The upper diagram shows the shaft power for the corresponding pump.

The lower diagram shows the performance data for each pump in terms of pressure (m) and flow rate (l/s).

Further data for each impeller is also shown in the table format.

□ = optimal duty point.

P_1 = motor input power
 P_2 = shaft power

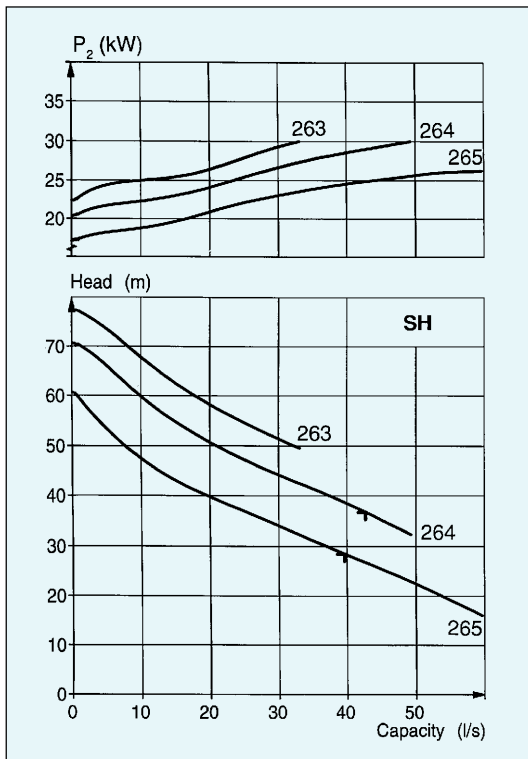

Impeller code	No. of vanes	Outlet dia. mm CP-vers	Through-let, mm	Motor rating kW		rpm	Available versions
				P_1	P_2		
263	1	100	Ø 76	34	30	2930	CP/CT/CS
264	1	100	Ø 76	34	30	2930	CP/CT/CS
265	1	100	Ø 76	34	30	2930	CP/CT/CS

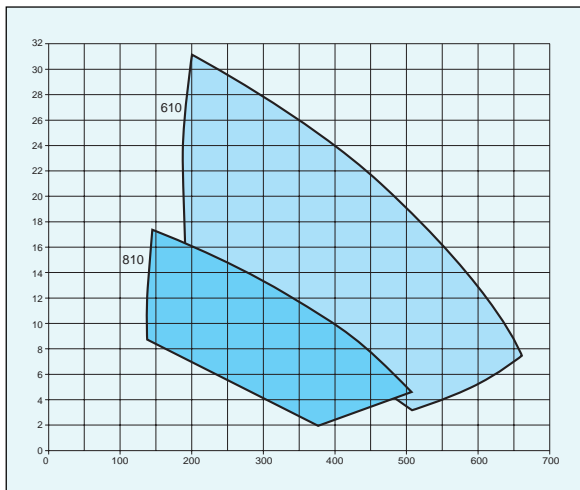

Large C pumps, P, PP and L pumps

This chart and table provides performance data for impellers used in a large C 3356 pump.

Each different impeller is coded for easy identification.

Impellers can be machined to achieve any duty point required within a field.

Impeller code	No. of vanes	Outlet dia. mm CP-vers	Through-let, mm	Motor rating kW		rpm	Available versions
				P_1	P_2		
610	3	350	Ø 102	82-150	75-140	990	CP/CT
810	3	350	Ø 102	61	55	735	CP/CT

B-PUMPS • 50 Hz

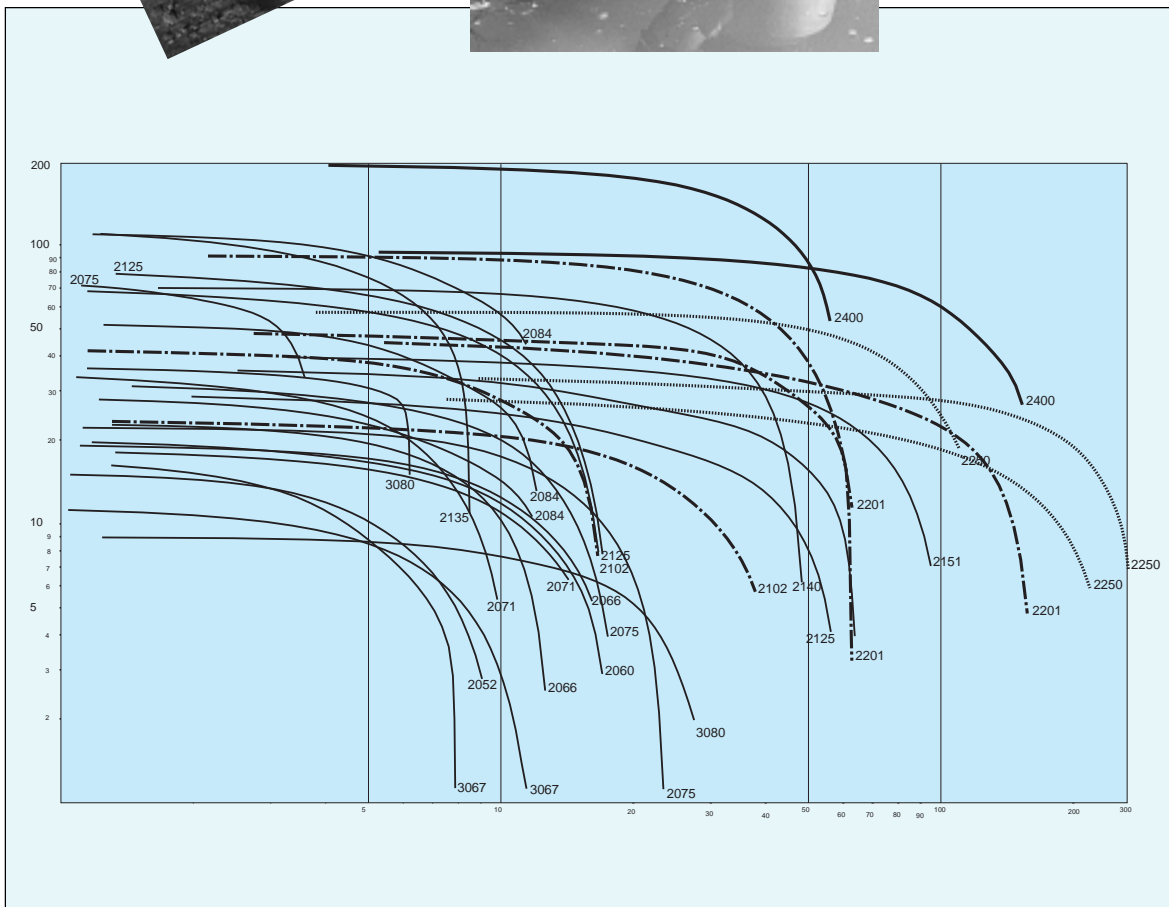

The B-pump has a multi-vaned, open or semi-open channel impeller available in different materials. It is specifically designed to handle media containing highly abrasive material, such as clay, sand, drilling mud, etc.



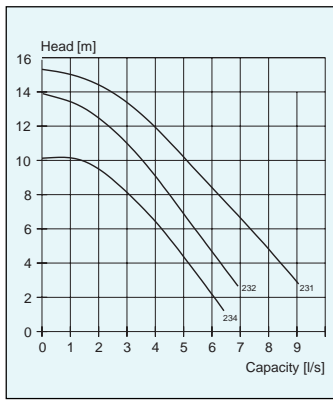

BIBO 2052

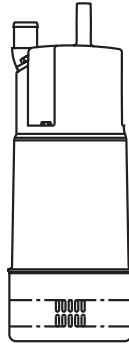

Technical data	MT	MT	MT
IMPELLERCODE	231	232	234
PHASE	3-	1-, 3-	1-, 3-
SPEED OF ROTATION	2700rpm	2700rpm	2700rpm
OUTPUT POWER	1.0kW	0.75kW, 1.0kW	0.75kW, 1.0kW
INPUT POWER	1.4kW	1kW, 1.4kW	1kW, 1.4kW
WEIGHT	18kg	18kg	18kg

Poly-Life® version available

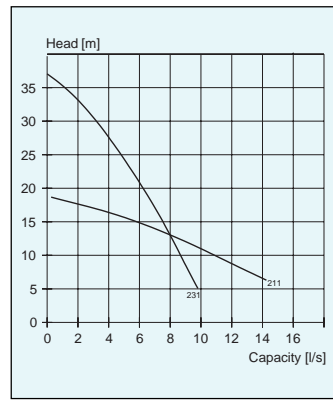

BIBO 2071

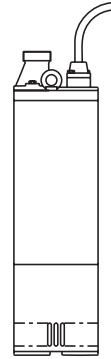

Technical data	MT	LT
IMPELLERCODE	231	211
PHASE	3-	3-
SPEED OF ROTATION	2800rpm	2800rpm
OUTPUT POWER	3kW	3kW
INPUT POWER	3.9kW	3.9kW
WEIGHT	31kg	28kg

Poly-Life® version available

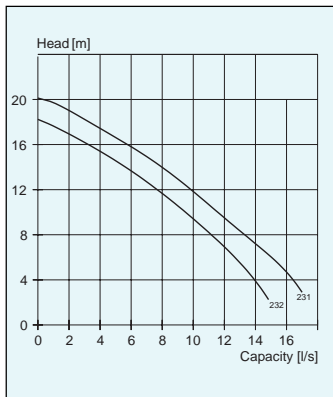

BIBO 2060

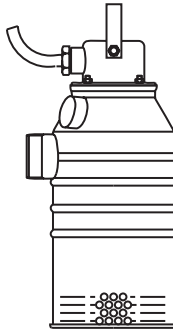

Technical data	MT	HT
IMPELLERCODE	231	232
PHASE	3	3
SPEED OF ROTATION	2800rpm	2800rpm
OUTPUT POWER	2.2kW	2.2kW
INPUT POWER	2.8kW	2.8kW
WEIGHT	32kg	32kg

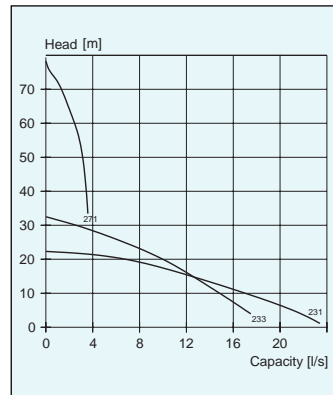

BIBO 2075

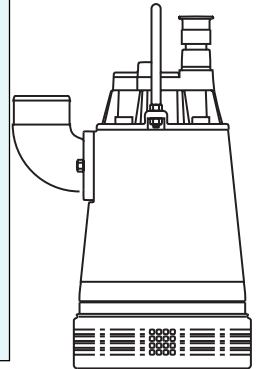

Technical data	MT	HT	ST
IMPELLERCODE	231	233	271
PHASE	3-	3-	3-
SPEED OF ROTATION	2800rpm	2800rpm	2800rpm
OUTPUT POWER	3.7kW	3.7kW	5.5kW
INPUT POWER	4.6kW	4.6kW	7.3kW
WEIGHT	73kg ¹⁾ 40kg ²⁾	73kg ¹⁾ 40kg ²⁾	90kg ¹⁾ 64kg ²⁾

¹⁾ Model 324 in cast iron

²⁾ Model 334 in hydraulic aluminum

Poly-Life® version available

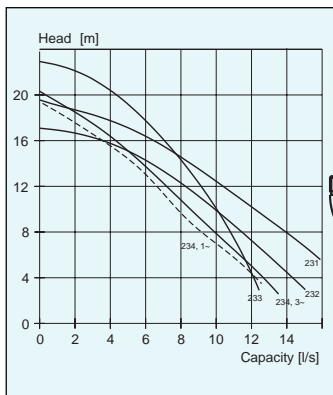

BIBO 2066

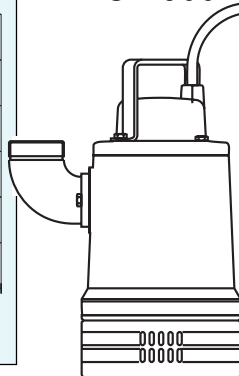

Technical data	MT	HT	HT
IMPELLERCODE	231, 232	233, 234	234-
PHASE	3-	3-	1-
SPEED OF ROTATION	2800rpm	2800rpm	2900rpm
OUTPUT POWER	2.2kW	2.2kW	1.5kW
INPUT POWER	2.8kW	2.8kW	1.9kW
WEIGHT	30kg	30kg	30kg

Poly-Life® version available

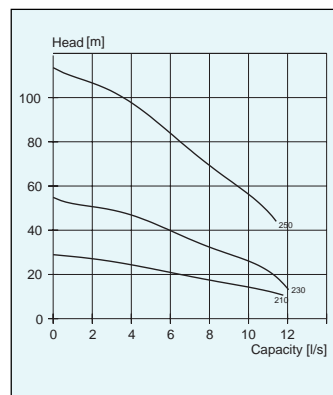

BIBO 2084



Technical data	MT	HT	LT
IMPELLER CODE	230	250	210
PHASE	3-	3-	3-
SPEED OF ROTATION	2880 rpm	2870 rpm	2850 rpm
OUTPUT POWER	7.5 kW	14 kW	3.7 kW
INPUT POWER	8.9 kW	16.4 kW	4.5 kW
WEIGHT	75 kg	110 kg	55 kg

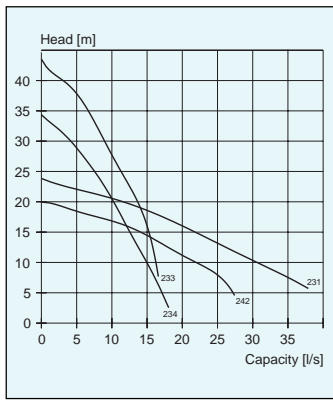

BIBO 2102

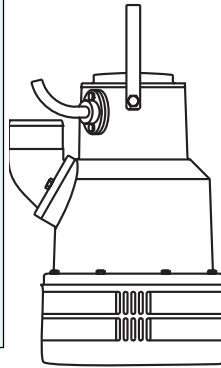

Technical data	MT	MT	HT	HT
IMPELLERCODE	242	231	234	233
PHASE	3~	3~	3~	3~
SPEED OF ROTATION	2850 rpm	2850 rpm	2850 rpm	2850 rpm
OUTPUT POWER	3.7 kW	5.2 kW	3.7 kW	5.2 kW
INPUT POWER	4.5 kW	6.3 kW	4.5 kW	6.3 kW
WEIGHT	48 kg	48 kg	48 kg	48 kg

Poly-Life® version available

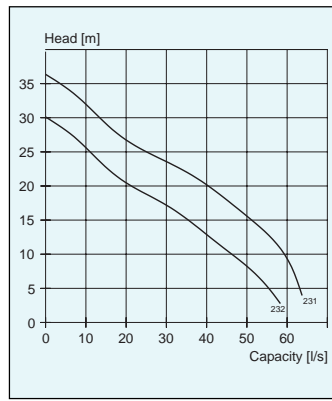

BIBO 2140

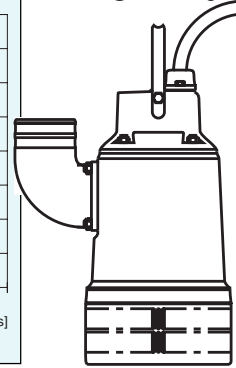

Technical data	MT
IMPELLERCODE	231/232
PHASE	3~
SPEED OF ROTATION	2875 rpm
OUTPUT POWER	12.0 kW
INPUT POWER	13.0 kW
WEIGHT	82 kg

Poly-Life® version available

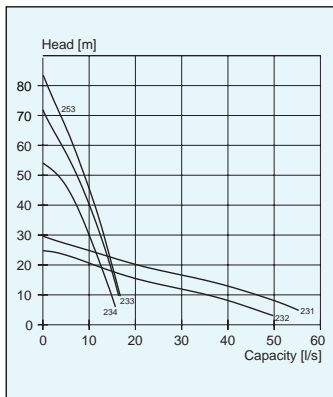

BIBO 2125

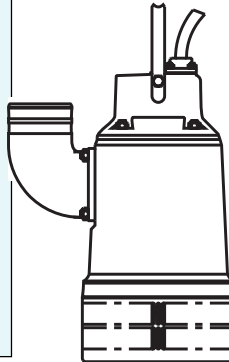

Technical data	MT	HT	SH
IMPELLERCODE	231/232	233/234	253
PHASE	3~	3~	3~
SPEED OF ROTATION	2875 rpm	2875 rpm	2915 rpm
OUTPUT POWER	8 kW	9.7 kW	11.1 kW
INPUT POWER	9.5 kW	11.1 kW	164 kg
WEIGHT	77 kg	80 kg	

Poly-Life® version available

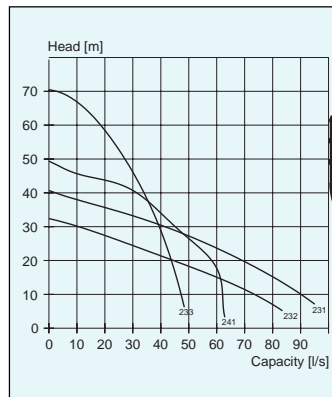

BIBO 2151

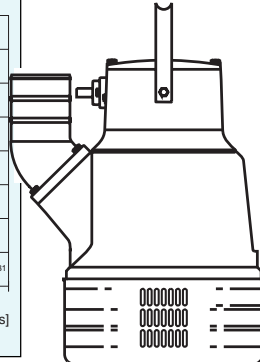

Technical data	MT	HT	LT
IMPELLERCODE	241	233	231/232
PHASE	3~	3~	3~
SPEED OF ROTATION	2900 rpm	2900 rpm	2900 rpm
OUTPUT POWER	20 kW	20 kW	20 kW
INPUT POWER	23 kW	23 kW	23 kW
WEIGHT	165 kg	165 kg	165 kg

Poly-Life® version available

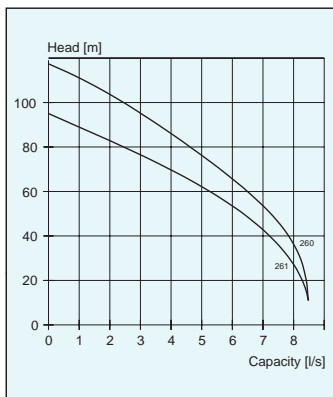

BIBO 2135

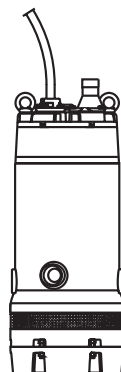

Technical data	HT
IMPELLERCODE	260
PHASE	3~
SPEED OF ROTATION	2920 rpm
OUTPUT POWER	13.5 kW
INPUT POWER	15.4 kW
WEIGHT	250 kg

Poly-Life® version available

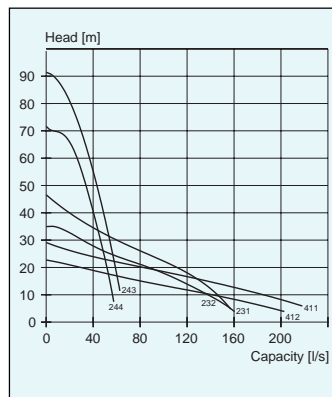

BIBO 2201



Technical data	MT	HT	LT
IMPELLERCODE	231/232	243/244	411/412
PHASE	3~	3~	3~
SPEED OF ROTATION	2940 rpm	2940 rpm	1465 rpm
OUTPUT POWER	37 kW	37 kW	30 kW
INPUT POWER	41 kW	41 kW	33 kW
WEIGHT	445 kg	350 kg	285 kg

Poly-Life® version available

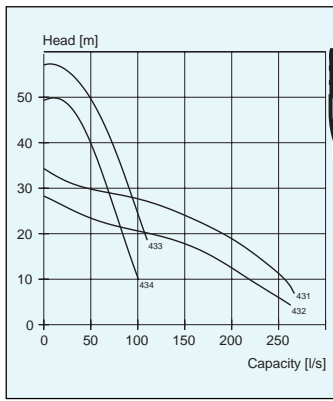

BIBO 2250

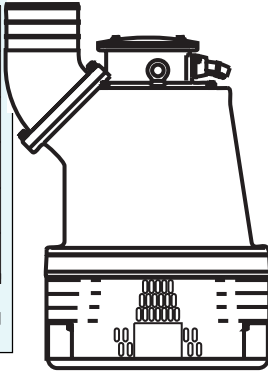

Technical data	MT	HT
IMPELLERCODE	431/432	433/434
PHASE	3-	3-
SPEED OF ROTATION	1475 rpm	1475 rpm
OUTPUT POWER	54 kW	54 kW
INPUT POWER	59 kW	59 kW
WEIGHT	540 kg	540 kg

Poly-Life® version available

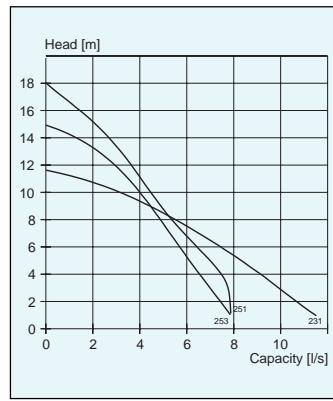

BIBO 3067

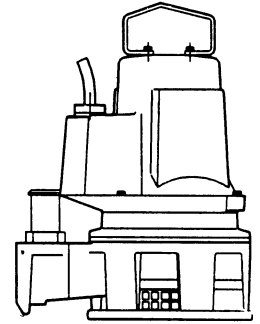

Impeller code	No. of vanes	Outlet dia mm CP vers.	Through-let, mm	Motor rating kW	rpm	Available versions
253	3	38	10	0.9*	2815	BP/BS
251	3	38	10	1.2	2815	BP/BS
231	6	38	10	1.2	2815	BP/BS

* Single phase

Weight, kg	BP	BS
HT / MT	34	34

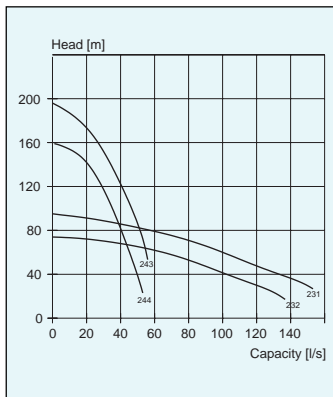

BIBO 2400

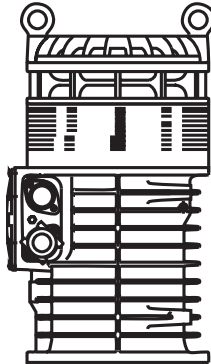

Technical data	MT	HT
IMPELLERCODE	231/232	243/244
PHASE	3-	3-
SPEED OF ROTATION	2970 rpm	2970 rpm
OUTPUT POWER	90 kW	90 kW
INPUT POWER	97 kW	97 kW
WEIGHT	900 kg	985 kg

Poly-Life® version available

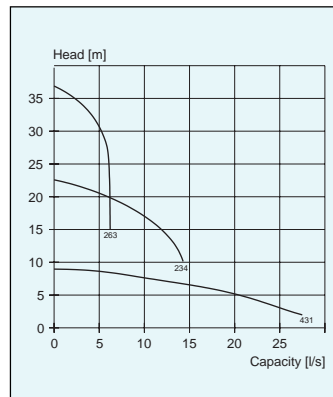

BIBO 3080

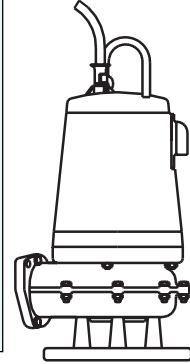

Technical data	MT	HT	ST
IMPELLERCODE	431	234	233
PHASE	3-	3-	3-
SPEED OF ROTATION	1400 rpm	2800 rpm	2800 rpm
OUTPUT POWER	4.0 kW	5.5 kW	5.5 kW
INPUT POWER	5.0 kW	7.3 kW	7.3 kW
WEIGHT	61 kg ¹⁾	61 kg ¹⁾	105 kg ³⁾
	100 kg ²⁾	100 kg ²⁾	

¹⁾Aluminium ²⁾Castiron ³⁾Alum-bronze

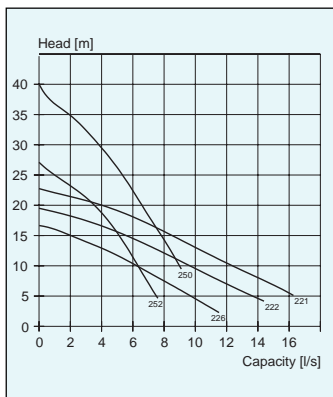

BIBO 3060

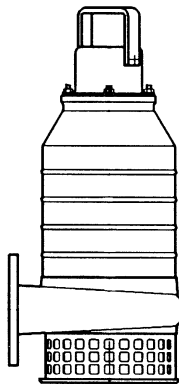

Technical data	MT	HT
IMPELLERCODE	221, 222, 226	250, 252
PHASE	3-	3-
SPEED OF ROTATION	2800 rpm	2800 rpm
OUTPUT POWER	2.4 kW	2.4 kW
INPUT POWER	3.3 kW	2.3 kW
WEIGHT	41 kg	41 kg

Poly-Life® version available

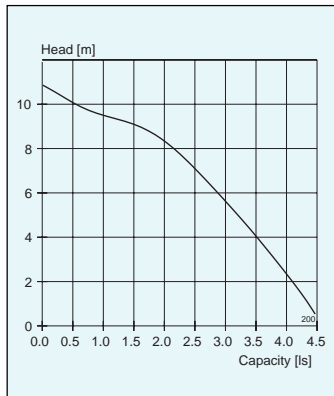

READY 4

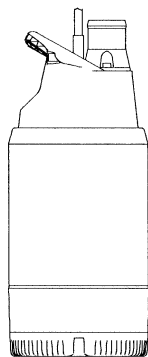

Technical data	MT
IMPELLERCODE	200
PHASE	1~
SPEED OF ROTATION	2700rpm
OUTPUT POWER	0.4kW
INPUT POWER	0.56kW
WEIGHT	9kg
OUTLET DIAMETER mm	Ø50

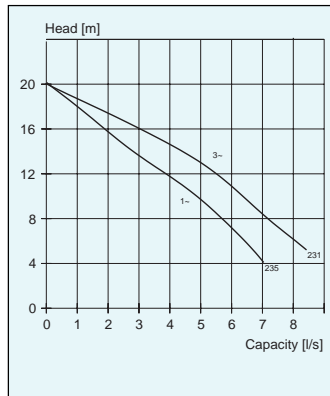

READY 16

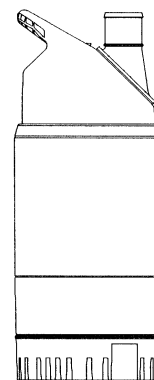

Technical data	MT	MT
IMPELLERCODE	231	235
PHASE	3~	1~
SPEED OF ROTATION	2800rpm	2750rpm
OUTPUT POWER	1.7kW	1.5kW
INPUT POWER	2.3 kW	2.0kW
WEIGHT	18kg	19kg
OUTLET DIAMETER mm	Ø50	Ø75

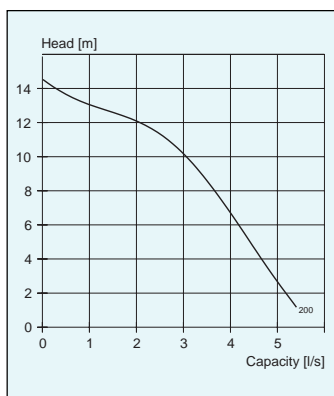

READY 8

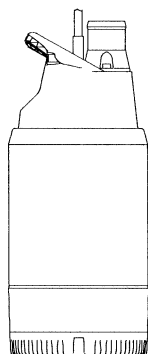

Technical data	MT
IMPELLERCODE	200
PHASE	1~
SPEED OF ROTATION	2800rpm
OUTPUT POWER	0.75kW
INPUT POWER	1.0kW
WEIGHT	11.5kg
OUTLET DIAMETER mm	Ø50

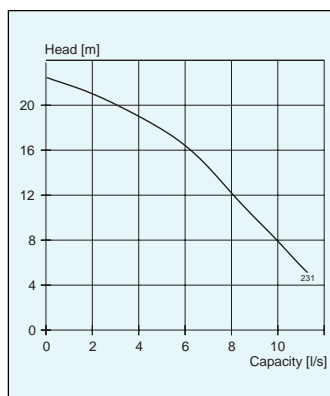

READY 24

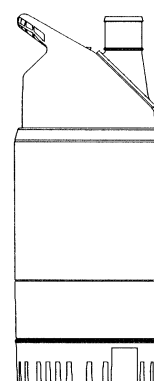

Technical data	MT
IMPELLERCODE	231
PHASE	3~
SPEED OF ROTATION	2700rpm
OUTPUT POWER	2.4kW
INPUT POWER	3.2kW
WEIGHT	19kg
OUTLET DIAMETER mm	Ø50/Ø75

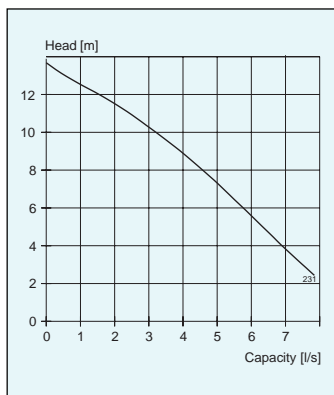

READY 12

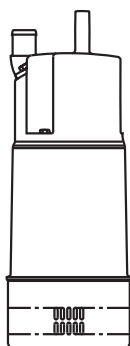

Technical data	MT
IMPELLERCODE	231
PHASE	3~
SPEED OF ROTATION	2650rpm
OUTPUT POWER	1.0kW
INPUT POWER	1.4kW
WEIGHT	18kg
OUTLET DIAMETER mm	Ø50

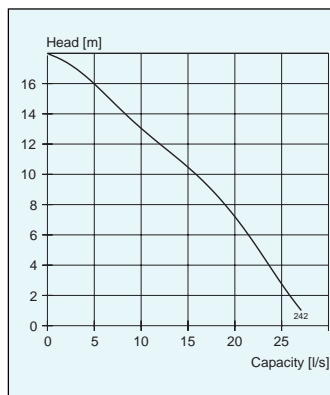

READY 40

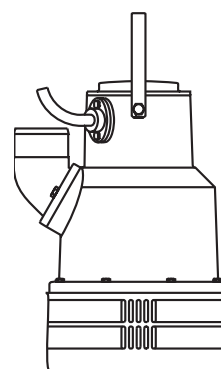

Technical data	MT
IMPELLERCODE	242
PHASE	3~
SPEED OF ROTATION	2800rpm
OUTPUT POWER	3.7kW
INPUT POWER	3.2kW
WEIGHT	19kg
OUTLET DIAMETER mm	Ø75/Ø100

C-PUMPS • 50 Hz

SMALL AND MEDIUM SIZE

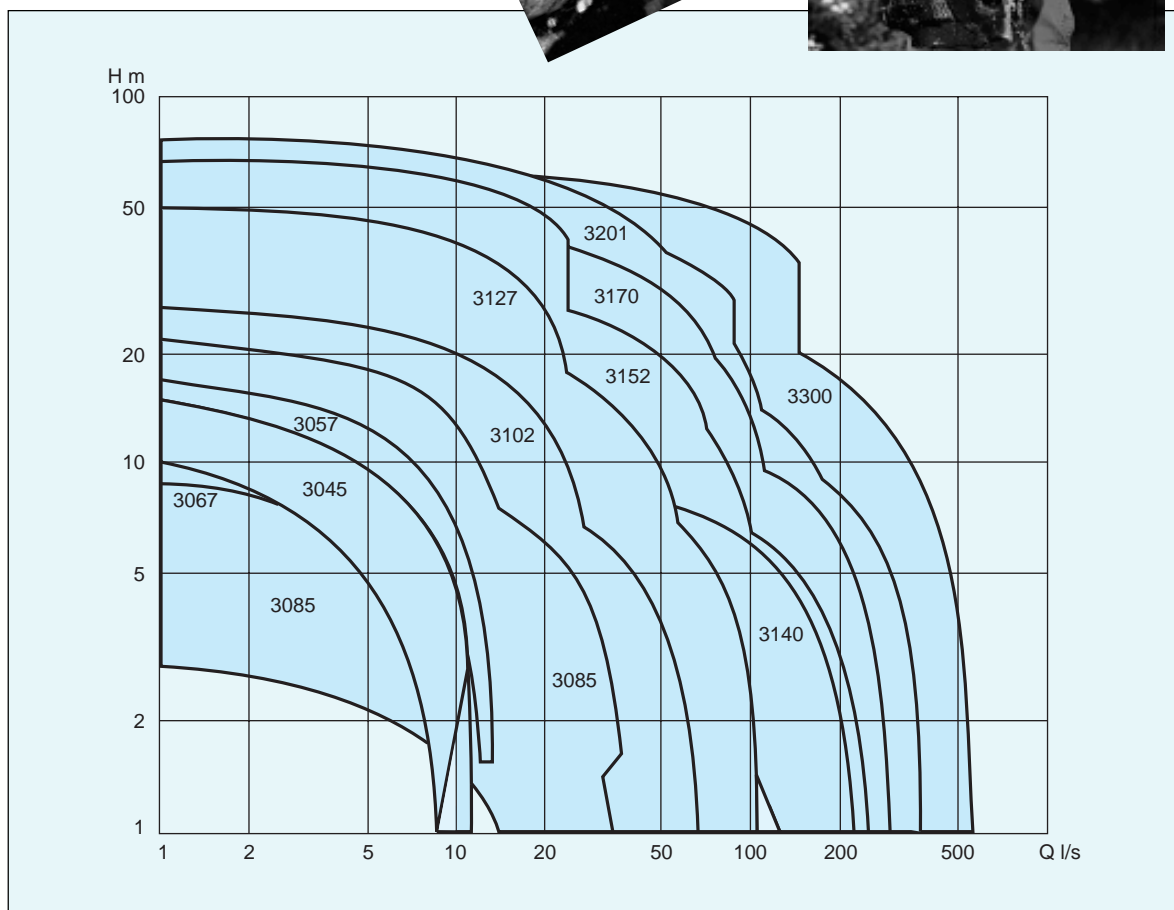

The conventional single-channel impeller is a shrouded channel impeller running in a volute. The shape and size of the channel minimize clogging, and therefore makes the pump ideal for waste water, containing large solid particles. See also chapter N-pumps.



C 3045

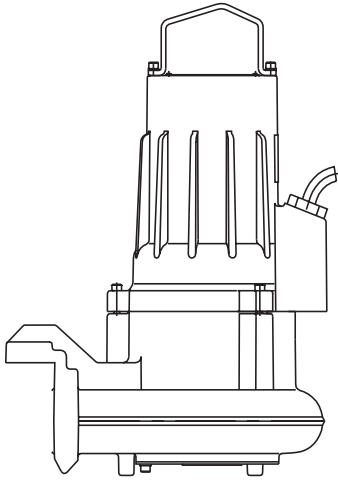

Pump type	CP	CF	CH	CS
Weight kg	28	28	28	28

CP/CF/CH/CS

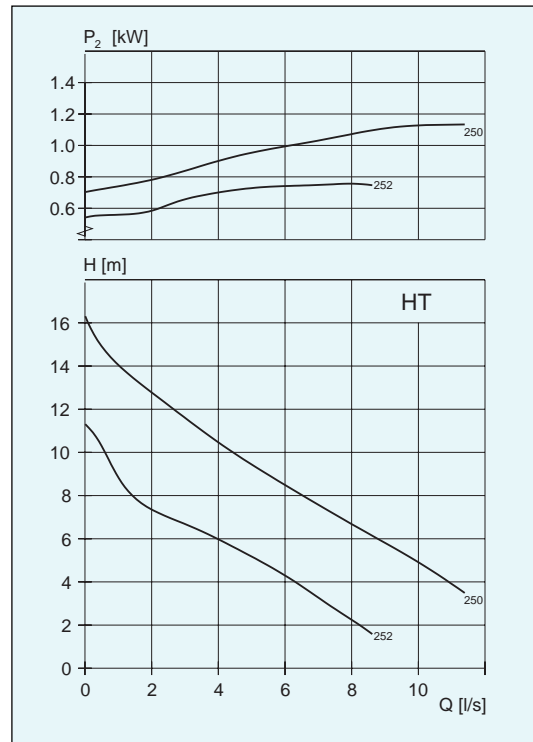

Impeller code	No. of vanes	Outlet dia mm CP vers.	Through-let, mm	Motor rating kW		rpm	Available versions
				P_1	P_2		
250	1	50	46	1.5	1.2	2790	CP/CF/CH/CS
252	1	50	46	1.5	1.2	2790	CP/CF/CH/CS
252	1	50	46	1.0	0.8	2870	CP/CF/CH/CS

CP/CF/CH/CS

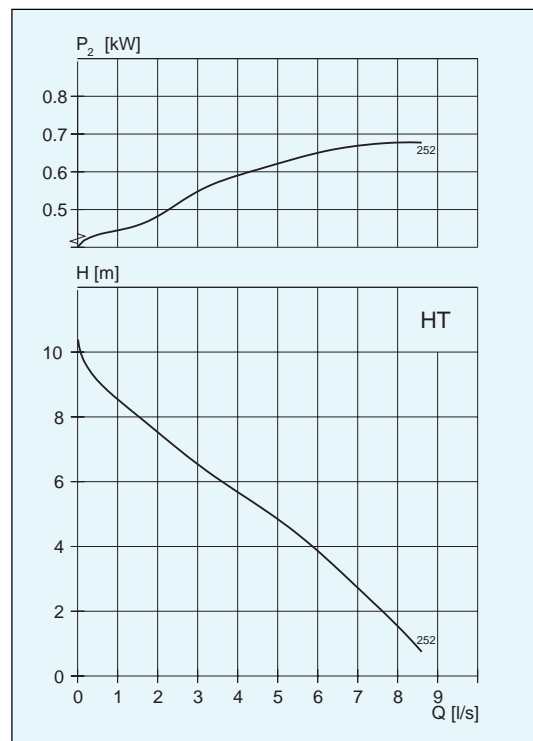

Impeller code	No. of vanes	Outlet dia mm CP vers.	Through-let, mm	Motor rating kW		rpm	Available versions
				P_1	P_2		
252*	1	50	46	1.0	0.75	2740	CP/CF/CH/CS

* Single phase

C 3057

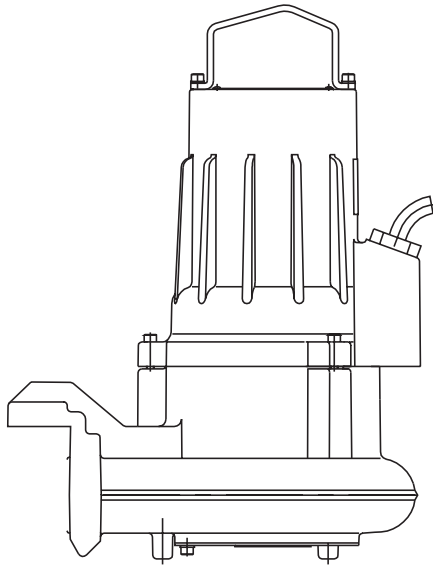

Weight kg	CP	CF	CS
HT	34	34	34

CP/CF/CS

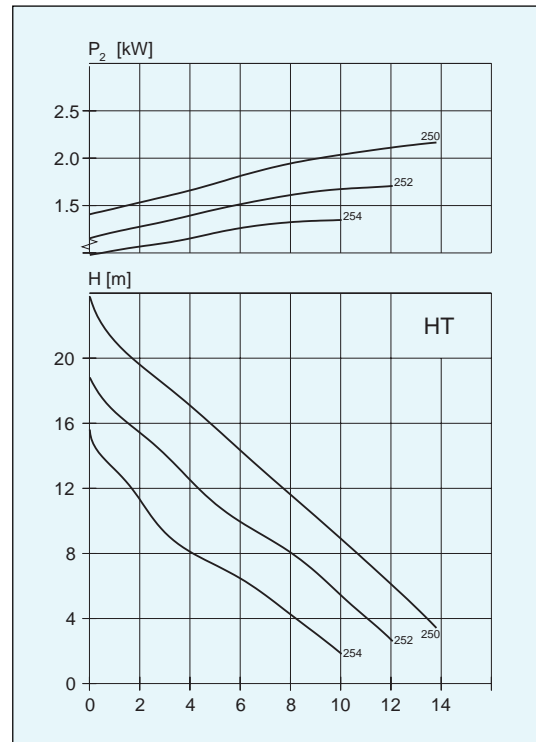

Impeller code	No. of vanes	Outlet dia mm CP vers.	Through-let, mm	Motor rating kW		rpm	Available versions
				P ₁	P ₂		
W250	1	50	48	3.1	2.4	2685	CP/CF/CS
250	1	50	48	2.3	1.7	2685	CP/CF/CS
W252	1	50	48	3.1	2.4	2685	CP/CF/CS
252	1	50	48	2.3	1.7	2685	CP/CF/CS
252*	1	50	48	2.1	1.5	2685	CP/CF/CS
W254	1	50	48	3.1	2.4	2685	CP/CF/CS
254	1	50	48	2.3	1.7	2685	CP/CF/CS
254*	1	50	48	2.1	1.5	2685	CP/CF/CS

* Single phase
W=Also available in a warm liquid version

C 3067

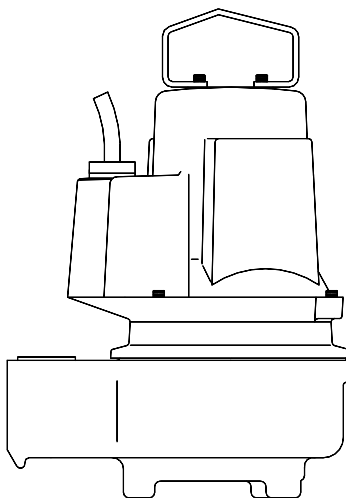

Weight kg	CP	CF	CH	CS
HT	39	40	39	49

CP/CF/CH/CS

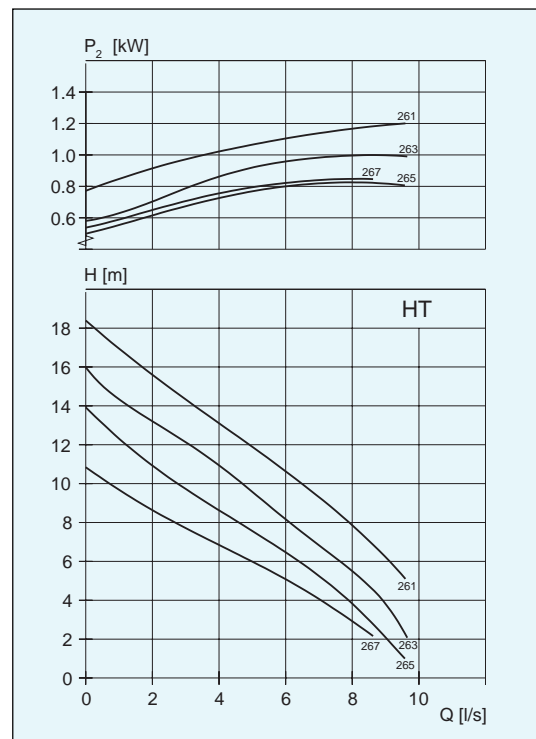

Impeller code	No. of vanes	Outlet dia mm CP vers.	Through-let, mm	Motor rating kW		rpm	Available versions
				P ₁	P ₂		
W261*	1	50	34	1.6	1.2	2820	CP/CF/CH/CS
W263*	1	50	34	1.6	1.2	2820	CP/CF/CH/CS
W265*	1	50	34	1.6	1.2	2820	CP/CF/CH/CS
W267*	1	50	34	1.6	1.2	2820	CP/CF/CH/CS
263**	1	50	34	1.5	1.0	2835	CP/CF/CH/CS

* NEVACLOG
** Single phase

C 3085

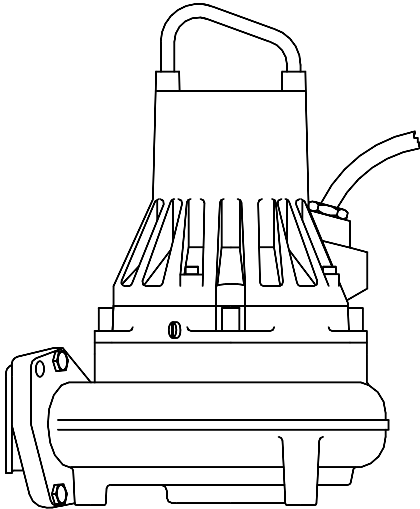

Weight, kg	CP	CF	CS	CT/CZ
LT	78	-	73	-
MT	66	68	71	88
HT	62	-	63	-

CP/CF/CS/CT/CZ

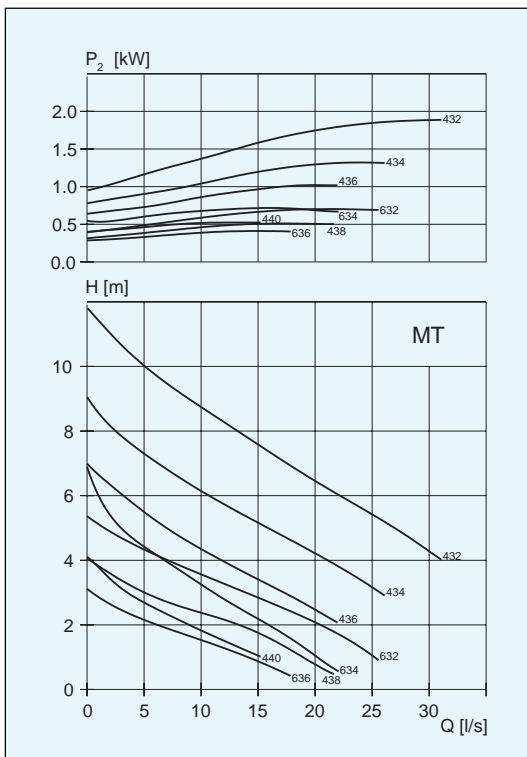

Impeller code	No. of vanes	Outlet dia mm CP vers.	Through-let, mm	Motor rating kW P ₁ P ₂	rpm	Available versions
W• 432*	1	80	∅ 76	2.7 2.0	1395	CP/CS/CF
W• 434*	1	80	∅ 76	2.7 2.0	1395	CP/CS/CF
W• 434*	1	80	∅ 76	1.8 1.3	1385	CP/CS/CF
434*	1	80	∅ 76	1.8 1.4	1430	CT/CZ
W• 436*	1	80	∅ 76	2.7 2.0	1395	CP/CS/CF
W• 436*	1	80	∅ 76	1.8 1.3	1385	CP/CS/CF
436*	1	80	∅ 76	1.8 1.4	1435	CT/CZ
436*	1	80	∅ 76	1.4 1.0	1420	CT/CZ
W• 438	1	80	64 x 86	2.7 2.0	1395	CP/CS/CF
W• 438	1	80	64 x 86	1.8 1.3	1385	CP/CS/CF
438	1	80	64 x 86	1.8 1.4	1430	CT/CZ
438	1	80	64 x 86	1.4 1.0	1415	CT/CZ
W• 440	1	80	64 x 95	2.7 2.0	1395	CP/CF/CS
W• 440	1	80	64 x 95	1.8 1.3	1385	CP/CF/CS
440	1	80	64 x 95	1.8 1.4	1430	CT/CZ
440	1	80	64 x 95	1.4 1.0	1415	CT/CZ
• 632*	1	80	∅ 76	1.3 0.9	940	CP/CF/CS
634*	1	80	∅ 76	1.3 0.9	940	CP/CF/CS
636*	1	80	∅ 76	1.3 0.9	940	CP/CF/CS
Single phase						
• 434	1	80	∅ 76	2.0 1.5	1440	CP/CF/CS
• 436	1	80	∅ 76	2.0 1.5	1440	CP/CF/CS
• 436	1	80	∅ 76	1.4 0.95	1440	CP/CF/CS
• 438	1	80	64 x 86	2.0 1.5	1440	CP/CF/CS
• 438	1	80	64 x 86	1.4 0.95	1440	CP/CF/CS
• 440	1	80	64 x 95	2.0 1.5	1440	CP/CF/CS
• 440	1	80	64 x 95	1.4 0.95	1440	CP/CF/CS

• Can be equipped with flush valve * NEVACLOG

CP/CS/CT/CZ

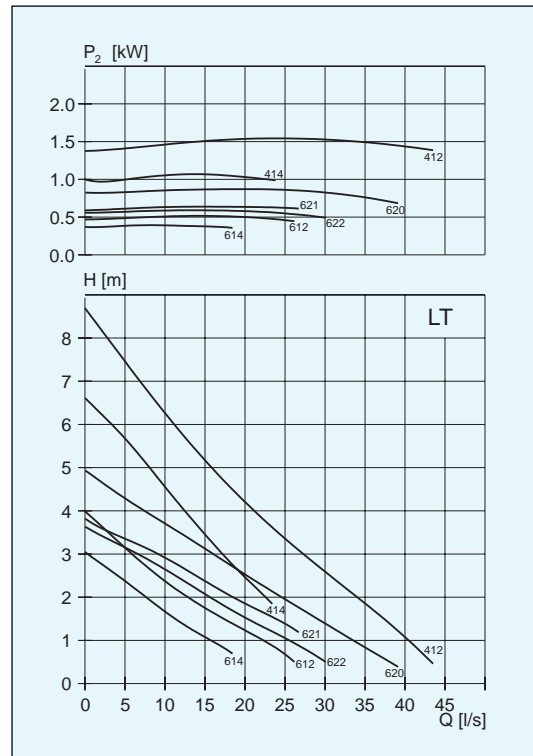

Impeller code	No. of vanes	Outlet dia mm CP vers.	Through-let, mm	Motor rating kW		rpm	Available versions
				P ₁	P ₂		
W• 412	1	100	∅ 100	2.7	2.0	1395	CP/CS
W• 414	1	100	80 x 100	2.7	2.0	1395	CP/CS
W• 414	1	100	80 x 100	1.8	1.3	1385	CP/CS
• 414	1	100	80 x 100	1.8	1.4	1430	CT/CZ
612	1	100	∅ 100	1.3	0.9	940	CP/CS
614	1	100	80 x 100	1.3	0.9	940	CP/CS
• 620	1	100	∅ 100	1.3	0.9	940	CP/CS
621	1	100	∅ 100	1.3	0.9	940	CP/CS
622	1	100	∅ 100	1.3	0.9	940	CP/CS

• Can be equipped with flush valve

CP/CS

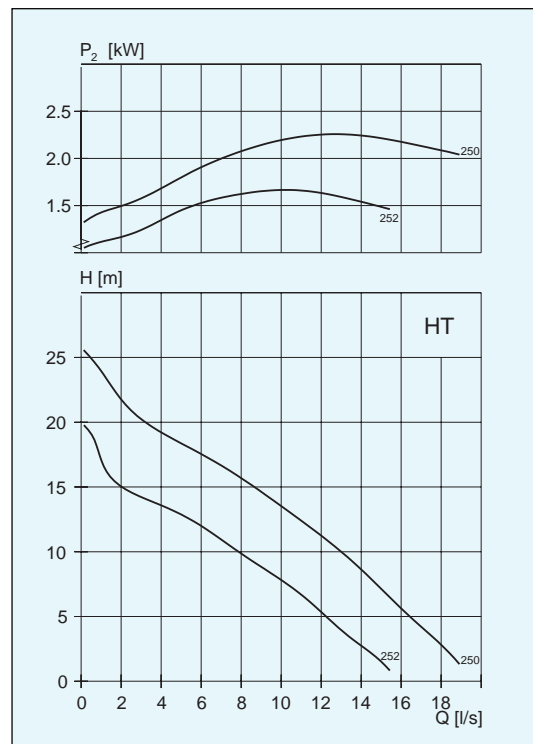

Impeller code	No. of vanes	Outlet dia mm CP vers.	Through-let, mm	Motor rating kW		rpm	Available versions
				P ₁	P ₂		
• 250	1	80	40 x 40	3.0	2.4	2830	CP/CS
• 252	1	80	40 x 40	3.0	2.4	2830	CP/CS

• Can be equipped with flush valve

C 3102

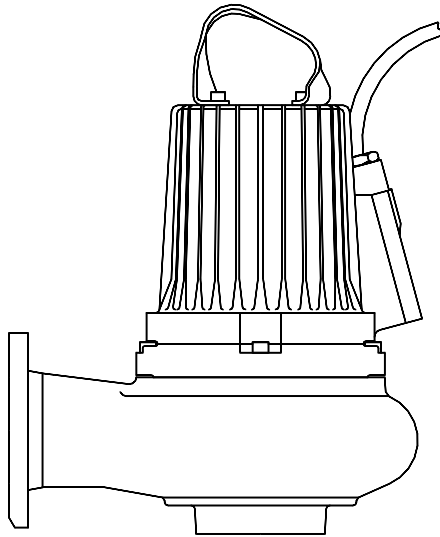

Weight, kg	CP	CT/CZ	CS
LT	117	163	135
MT	112	132	121
HT	105	-	114

- Can be equipped with flush valve.
- * NEVACLOG

CP/CS/CT/CZ

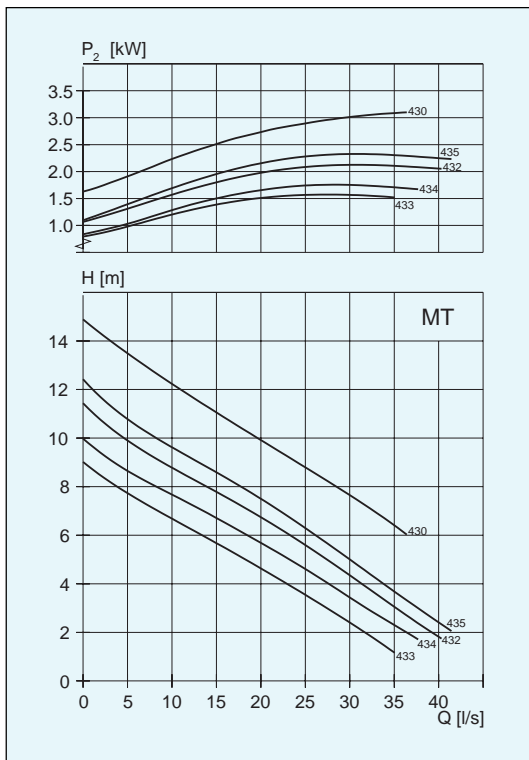

Impeller code	No. of vanes	Outlet dia mm CP vers.	Through-let, mm	Motor rating kW		rpm	Available versions
				P ₁	P ₂		
W• 430*	1	100	∅ 76	3.8	3.1	1440	CP/CS
W• 432*	1	100	∅ 76	3.8	3.1	1440	CP/CS
W• 433*	1	100	∅ 76	3.8	3.1	1440	CP/CS
W• 434*	1	100	∅ 76	3.8	3.1	1440	CP/CS
W• 435*	1	100	∅ 76	3.8	3.1	1440	CP/CS
432	1	100	∅ 76	2.9	2.4	1455	CT/CZ
433	1	100	∅ 76	2.9	2.4	1455	CT/CZ
434	1	100	∅ 76	2.9	2.4	1455	CT/CZ
435	1	100	∅ 76	2.9	2.4	1455	CT/CZ

CP/CS/CT/CZ

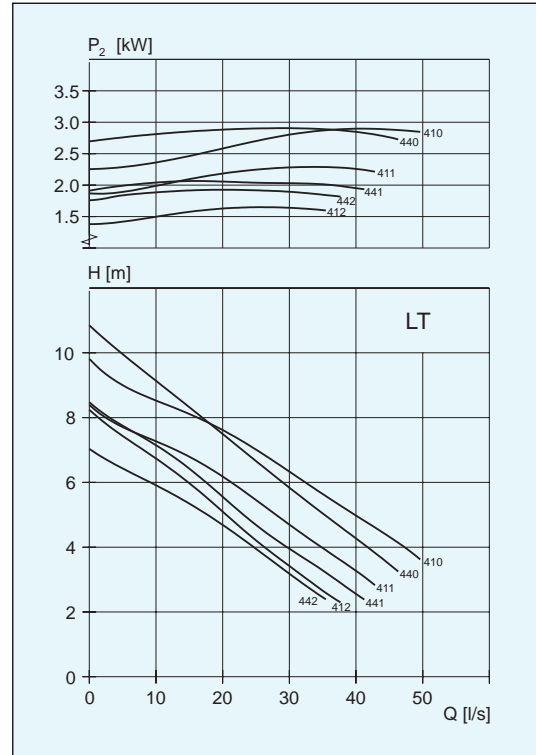

Impeller code	No. of vanes	Outlet dia mm CP vers.	Through-let, mm	Motor rating kW		rpm	Available versions
				P ₁	P ₂		
W• 410	2	100/150	55 x 100	3.8	3.1	1435	CP/CS
W• 411	2	100/150	52 x 96	3.8	3.1	1435	CP/CS
W• 412	2	100/150	54 x 88	3.8	3.1	1435	CP/CS
W• 440	1	100/150	∅ 100	3.8	3.1	1435	CP/CS
W• 441	1	100/150	∅ 100	3.8	3.1	1435	CP/CS
W• 442	1	100/150	∅ 100	3.8	3.1	1435	CP/CS
411	2	100/150	52 x 96	2.9	2.4	1450	CT/CZ
412	2	100/150	54 x 88	2.9	2.4	1450	CT/CZ
441	1	100/150	∅ 100	2.9	2.4	1450	CT/CZ
442	1	100/150	∅ 100	2.9	2.4	1450	CT/CZ

CP/CS

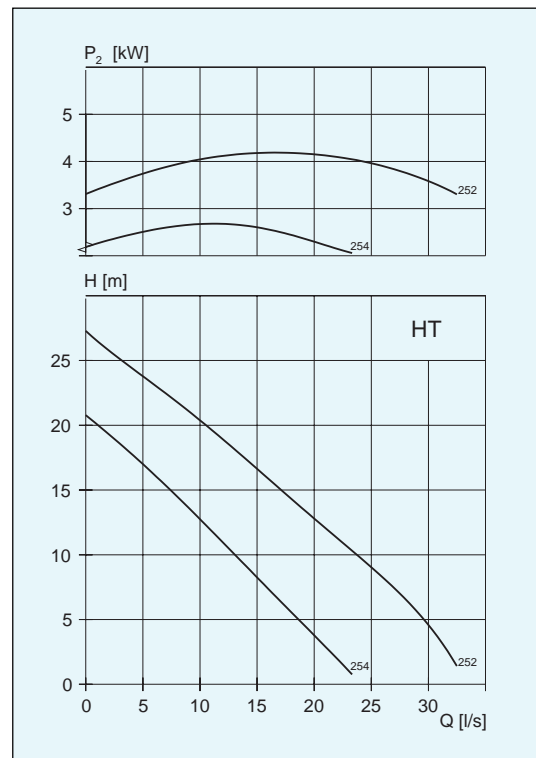

Impeller code	No. of vanes	Outlet dia mm CP vers.	Through-let, mm	Motor rating kW		rpm	Available versions
				P ₁	P ₂		
• 252	1	80	∅ 52	5.4	4.4	2870	CP/CS
• 254	1	80	∅ 52	5.4	4.4	2870	CP/CS

C 3127

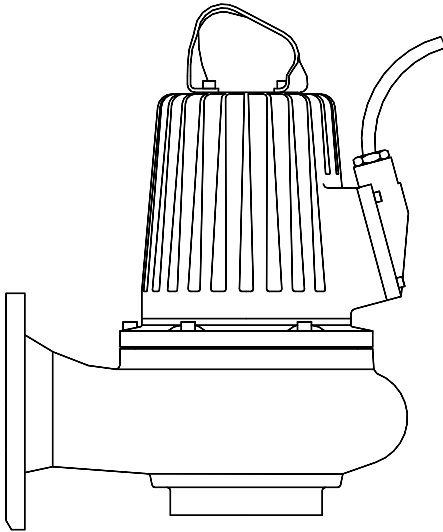

Weight, kg	CP	CT/CZ	CS
LT	154	221	181
MT	142	188	158

CP/CS/CT/CZ

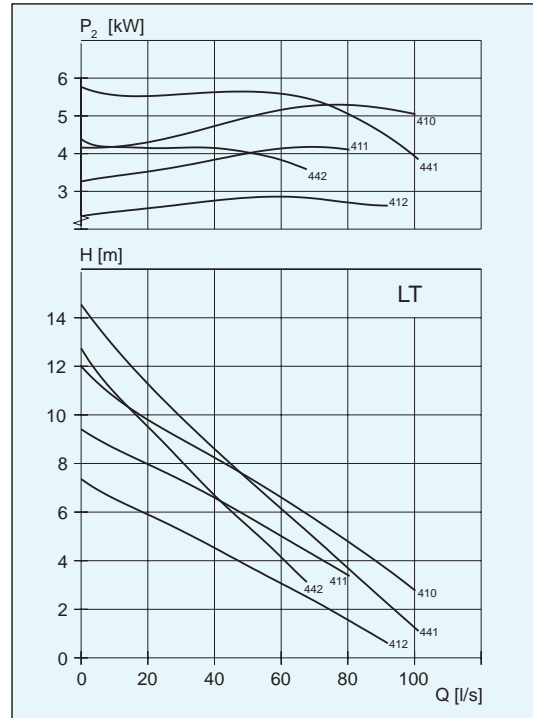

CP/CS/CT/CZ

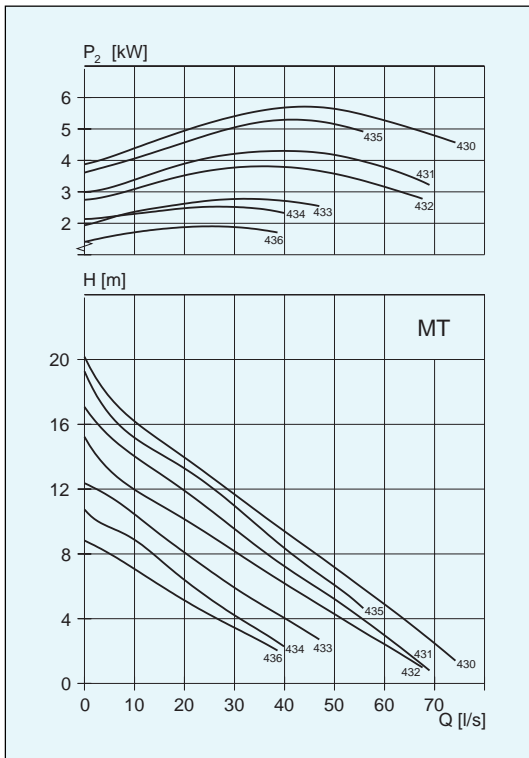

Impeller code	No. of vanes	Outlet dia mm CP vers.	Through-let, mm	Motor rating kW		rpm	Available versions
				P ₁	P ₂		
W•410	2	200	∅76	7.0	5.9	1450	CP/CS
W•411	2	200	∅76	7.0	5.9	1450	CP/CS
•411	2	200	∅76	5.7	4.7	1450	CP/CS
W•412	2	200	∅76	7.0	5.9	1450	CP/CS
•412	2	200	∅76	5.7	4.7	1450	CP/CS
W•441	1	200	107x117	7.0	5.9	1450	CP/CS
W•442	1	200	∅76	7.0	5.9	1450	CP/CS
•442	1	200	∅76	5.7	4.7	1450	CP/CS
411	2	200	∅76	5.6	4.7	1460	CT/CZ
412	2	200	∅76	4.8	4.0	1460	CT/CZ
412	2	200	∅76	5.6	4.7	1460	CT/CZ
442	1	200	∅76	4.8	4.0	1460	CT/CZ
442	1	200	∅76	5.6	4.7	1460	CT/CZ

Impeller code	No. of vanes	Outlet dia mm CP vers.	Through-let, mm	Motor rating kW		rpm	Available versions
				P ₁	P ₂		
W•430	1	100/150	100x110	7.1	5.9	1445	CP/CS
W•431	1	100/150	90x100	7.1	5.9	1445	CP/CS
•431	1	100/150	90x100	5.7	4.7	1445	CP/CS
W•432	1	100/150	87x100	7.1	5.9	1445	CP/CS
•432	1	100/150	87x100	5.7	4.7	1445	CP/CS
W•433	1	100/150	82x100	7.1	5.9	1445	CP/CS
•433	1	100/150	82x100	5.7	4.7	1445	CP/CS
W•434	1	100/150	80x100	7.1	5.9	1445	CP/CS
•434	1	100/150	80x100	5.7	4.7	1445	CP/CS
W•435	1	100/150	∅100	7.1	5.9	1445	CP/CS
W•436	1	100/150	∅100	7.1	5.9	1445	CP/CS
•436	1	100/150	∅100	5.7	4.7	1445	CP/CS
•431	1	100/150	90x100	5.6	4.7	1460	CT/CZ
•432	1	100/150	87x100	5.6	4.7	1460	CT/CZ
•432	1	100/150	87x100	4.8	4.0	1455	CT/CZ
•433	1	100/150	82x100	5.6	4.7	1460	CT/CZ
•433	1	100/150	82x100	4.8	4.0	1455	CT/CZ
•434	1	100/150	80x100	5.6	4.7	1460	CT/CZ
•434	1	100/150	80x100	4.8	4.0	1455	CT/CZ
•436	1	100/150	∅100	5.6	4.7	1460	CT/CZ
•436	1	100/150	∅100	4.8	4.0	1455	CT/CZ

• Can be equipped with flush valve. * NEVACLOG

C 3127

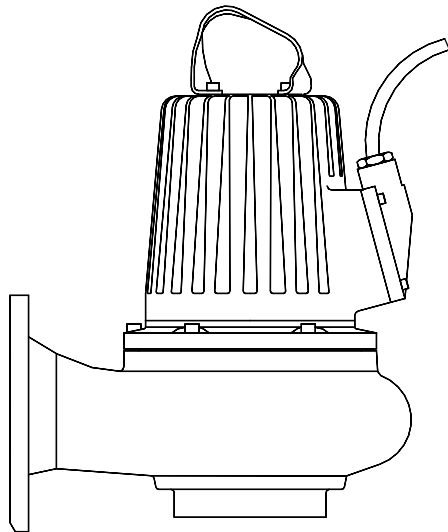

Weight, kg	CP	CT/CZ	CS
HT	136	156	142
SH	136	-	142

CP/CS/CT/CZ

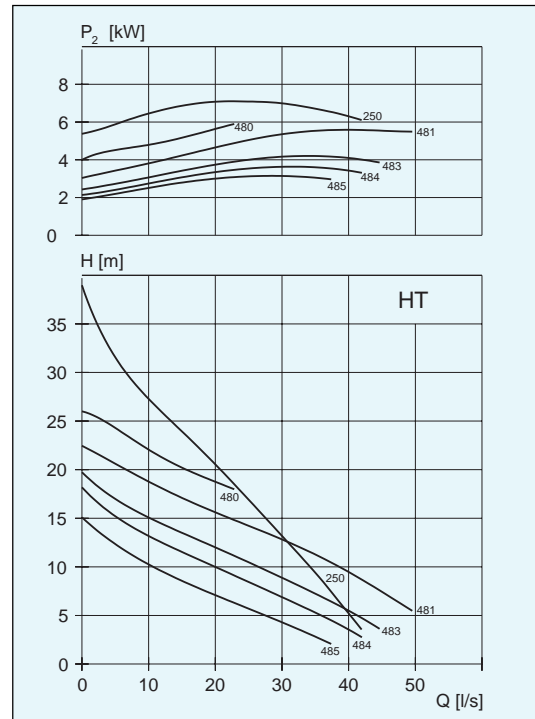

CP/CS

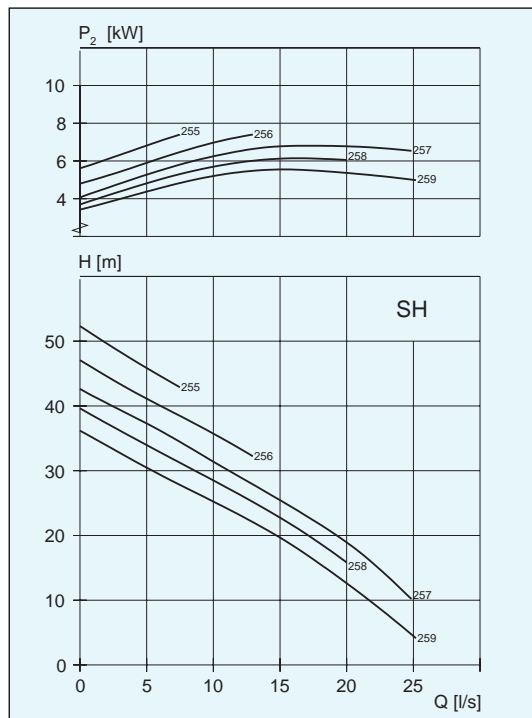

Impeller code	No. of vanes	Outlet dia mm CP vers.	Through-let, mm	Motor rating kW		rpm	Available versions
				P ₁	P ₂		
•250	1	80	∅ 58	8.7	7.4	2900	CP/CS
W•480*	1	100	∅ 76	7.1	5.9	1445	CP/CS
W•481*	1	100	∅ 76	7.1	5.9	1445	CP/CS
W•483*	1	100	∅ 76	7.1	5.9	1445	CP/CS
•483*	1	100	∅ 76	5.7	4.7	1445	CP/CS
W•484*	1	100	∅ 76	7.1	5.9	1445	CP/CS
•484*	1	100	∅ 76	5.7	4.7	1445	CP/CS
W•485*	1	100	∅ 76	7.1	5.9	1445	CP/CS
•485*	1	100	∅ 76	5.7	4.7	1445	CP/CS
•483*	1	100	∅ 76	5.6	4.7	1460	CT/CZ
•484*	1	100	∅ 76	5.6	4.7	1460	CT/CZ
•484*	1	100	∅ 76	4.8	4.0	1460	CT/CZ
•485*	1	100	∅ 76	5.6	4.7	1460	CT/CZ
•485*	1	100	∅ 76	4.8	4.0	1460	CT/CZ

• Can be equipped with flush valve. * NEVACLOG

Impeller code	No. of vanes	Outlet dia mm CP vers.	Through-let, mm	Motor rating kW		rpm	Available versions
				P ₁	P ₂		
•255	1	80	40 x 40	8.7	7.4	2900	CP/CS
•256	1	80	40 x 40	8.7	7.4	2900	CP/CS
•257	1	80	40 x 40	8.7	7.4	2900	CP/CS
•258	1	80	40 x 40	8.7	7.4	2900	CP/CS
•259	1	80	40 x 40	8.7	7.4	2900	CP/CS

C 3140

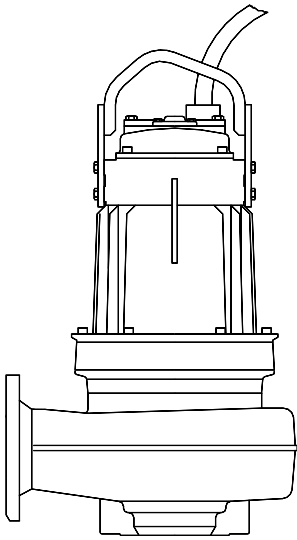

Weight, kg	CP	CS
LT	378	436
MT	283	364
HT	283	310

• Can be equipped with flush valve.

CP/CS

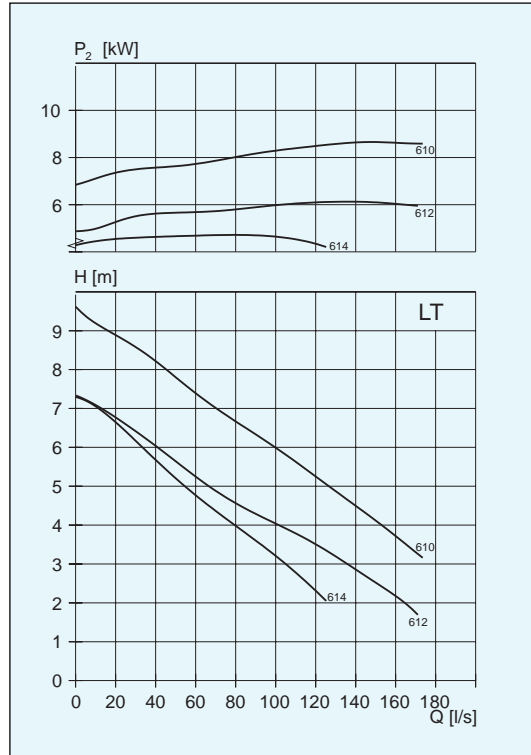

Impeller code	No. of vanes	Outlet dia mm CP vers.	Through-let, mm	Motor rating kW		rpm	Available versions
				P ₁	P ₂		
•610	2	250	102 x 110	10.5	8.8	955	CP/CS
•612	2	250	102 x 110	10.5	8.8	955	CP/CS
•614	2	250	82 x 95	10.5	8.8	955	CP/CS

CP/CS

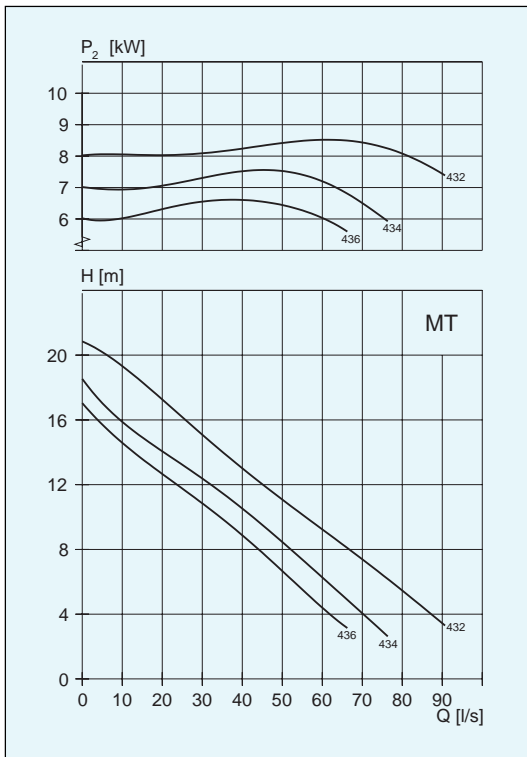

Impeller code	No. of vanes	Outlet dia mm CP vers.	Through-let, mm	Motor rating kW		rpm	Available versions
				P ₁	P ₂		
•432	1	150	100 x 109	10.7	9	1455	CP/CS
•434	1	150	100 x 100	10.7	9	1455	CP/CS
•436	1	150	93 x 100	10.7	9	1455	CP/CS

CP/CS

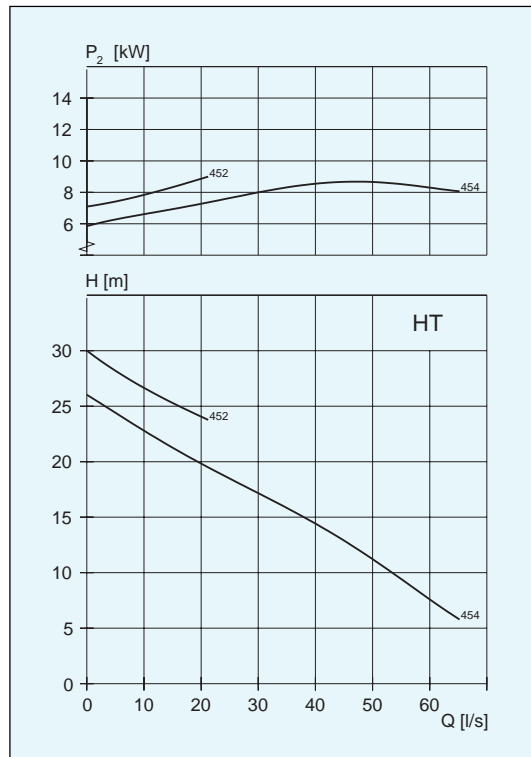

Impeller code	No. of vanes	Outlet dia mm CP vers.	Through-let, mm	Motor rating kW		rpm	Available versions
				P ₁	P ₂		
•452	1	100	∅76	10.7	9	1455	CP/CS
•454	1	100	∅76	10.7	9	1455	CP/CS

C 3152

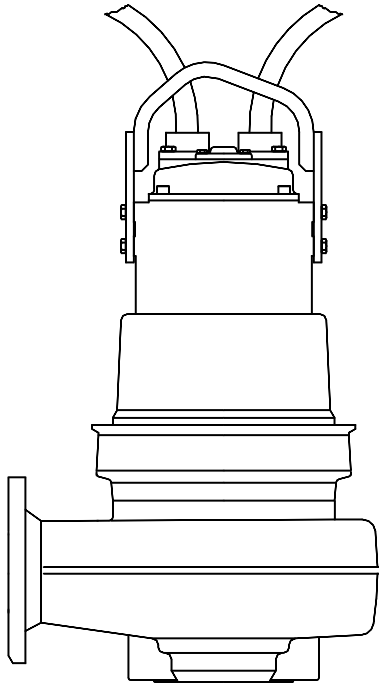

Weight, kg (with cooling jacket)	CP	CS	CT/CZ
LT	368	425	466
MT	279	320	348
HT	270	289	314

CP/CS/CT/CZ

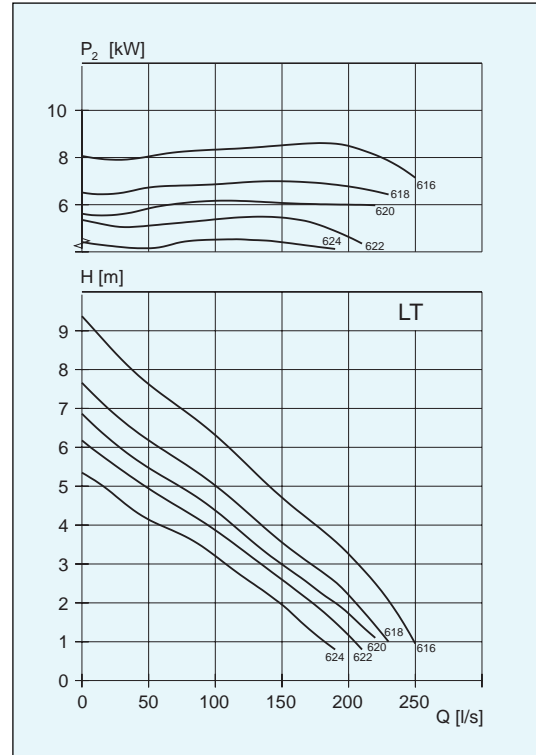

Impeller code	No. of vanes	Outlet dia mm CP vers.	Through-let, mm	Motor rating kW		rpm	Available versions
				P ₁	P ₂		
W• 616	2	300	102x102	10.5	8.8	955	CP/CS/CT/CZ
W• 618	2	300	102x102	10.5	8.8	955	CP/CS/CT/CZ
W• 620	2	300	102x102	10.5	8.8	955	CP/CS/CT/CZ
W• 622	2	300	102x102	10.5	8.8	955	CP/CS/CT/CZ
W• 624	2	300	102x102	10.5	8.8	955	CP/CS/CT/CZ

• Can be equipped with flush valve

CP/CS/CT/CZ

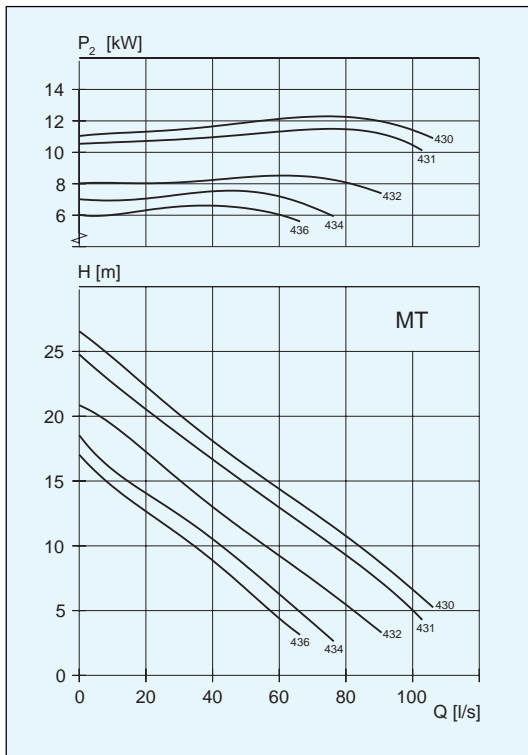

Impeller code	No. of vanes	Outlet dia mm CP vers.	Through-let, mm	Motor rating kW		rpm	Available versions
				P ₁	P ₂		
• 430	1	200	100x115	15.8	13.5	1450	CP/CS/CT/CZ
W• 431	1	200	100x110	15.8	13.5	1450	CP/CS/CT/CZ
W• 432	1	200	109x100	15.8	13.5	1450	CP/CS/CT/CZ
• 432	1	200	109x100	10.7	9	1455	CP/CS/CT/CZ
W• 434	1	200	100x100	15.8	13.5	1450	CP/CS/CT/CZ
• 434	1	200	100x100	10.7	9	1455	CP/CS/CT/CZ
W• 436	1	200	100x93	15.8	13.5	1450	CP/CS/CT/CZ
• 436	1	200	100x93	10.7	9	1455	CP/CS/CT/CZ

• Can be equipped with flush valve

CP/CS/CT/CZ

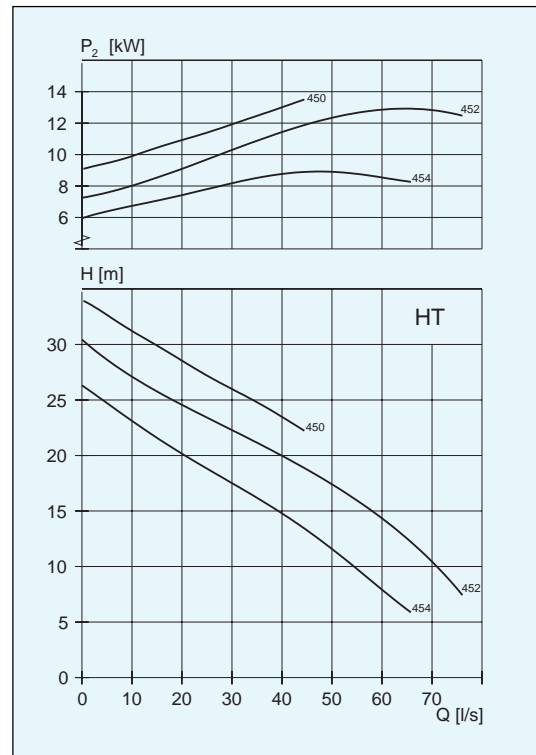

Impeller code	No. of vanes	Outlet dia mm CP vers.	Through-let, mm	Motor rating kW		rpm	Available versions
				P ₁	P ₂		
W• 450	1	100/150	∅ 76	15.8	13.5	1450	CP/CS/CT/CZ
W• 452	1	100/150	∅ 76	15.8	13.5	1450	CP/CS/CT/CZ
W• 454	1	100/150	∅ 76	15.8	13.5	1450	CP/CS/CT/CZ
• 454	1	100/150	∅ 76	10.7	9	1455	CP/CS/CT/CZ

• Can be equipped with flush valve

C 3152 SH

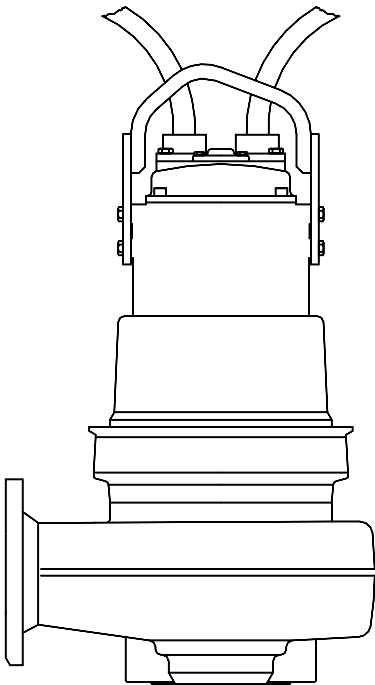

Weight, kg (with cooling jacket)	CP	CS	CT/CZ
SH	262	261	266

CP/CS/CT/CZ

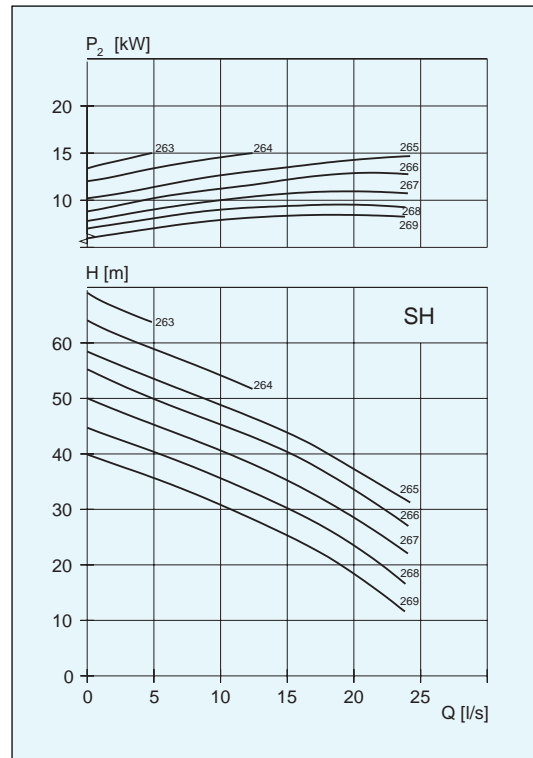

Impeller code	No. of vanes	Outlet dia mm CP vers.	Through-let, mm	Motor rating kW		rpm	Available versions
				P ₁	P ₂		
•263	1	100	40 x 40	17.0	15	2920	CP/CS/CT/CZ
•264	1	100	40 x 40	17.0	15	2920	CP/CS/CT/CZ
•265*	1	100	40 x 40	17.0	15	2920	CP/CS/CT/CZ
•266*	1	100	40 x 40	17.0	15	2920	CP/CS/CT/CZ
•267*	1	100	40 x 40	17.0	15	2920	CP/CS/CT/CZ
•268*	1	100	40 x 40	17.0	15	2920	CP/CS/CT/CZ
•269*	1	100	40 x 40	17.0	15	2920	CP/CS/CT/CZ

* NPSH_{re} = 11 m at 20 l/s • Can be equipped with flush valve

C 3170

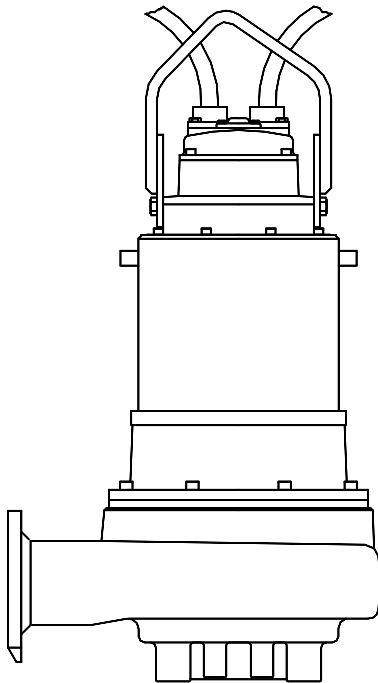

Weight, kg (with cooling jacket)	CP	CS	CT/CZ
LT	575	615	670
MT	522	542	572
HT	480	527	530

CP/CS/CT/CZ

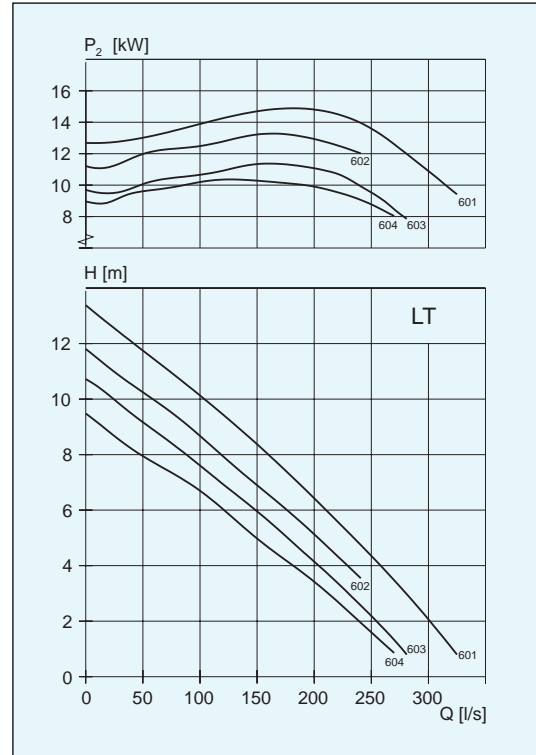

Impeller code	No. of vanes	Outlet dia mm CP vers.	Through-let, mm	Motor rating kW		rpm	Available versions
				P ₁	P ₂		
W•601	2	250	102x102	17.5	15	970	CP/CS/CT/CZ
W•602	2	250	102x102	17.5	15	970	CP/CS/CT/CZ
W•603	2	250	102x102	17.5	15	970	CP/CS/CT/CZ
W•604	2	250	102x102	17.5	15	970	CP/CS/CT/CZ

• Can be equipped with flush valve

CP/CS/CT/CZ

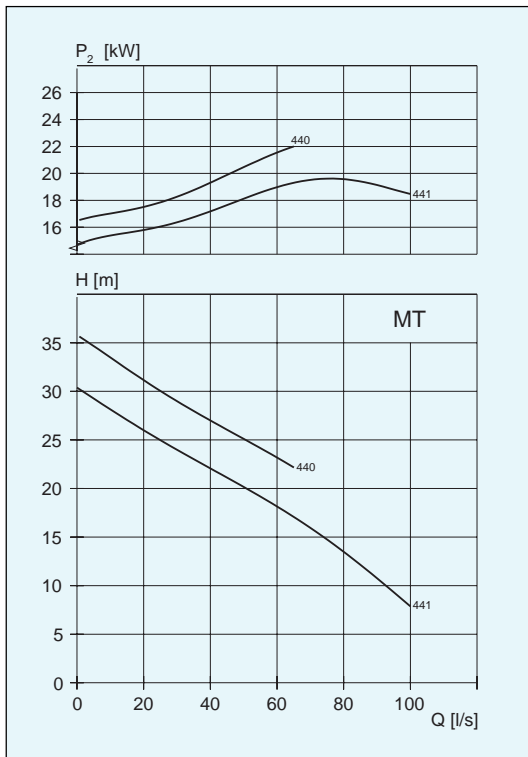

Impeller code	No. of vanes	Outlet dia mm CP vers.	Through-let, mm	Motor rating kW		rpm	Available versions
				P ₁	P ₂		
W•440	1	200	∅100	25	22	1460	CP/CS/CT/CZ
W•441	1	200	∅100	25	22	1460	CP/CS/CT/CZ

CP/CS/CT/CZ

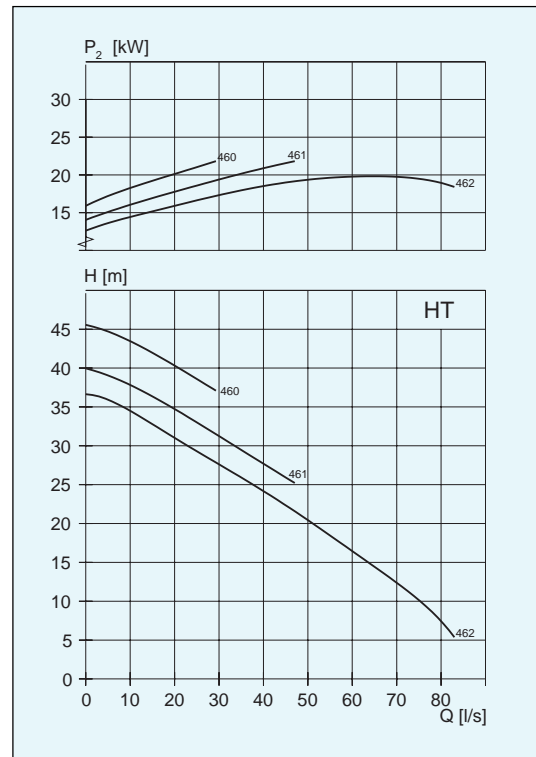

Impeller code	No. of vanes	Outlet dia mm CP vers.	Through-let, mm	Motor rating kW		rpm	Available versions
				P ₁	P ₂		
W•460	1	150	77x80	25	22	1460	CP/CS/CT/CZ
W•461	1	150	77x80	25	22	1460	CP/CS/CT/CZ
W•462	1	150	∅77	25	22	1460	CP/CS/CT/CZ

C 3201

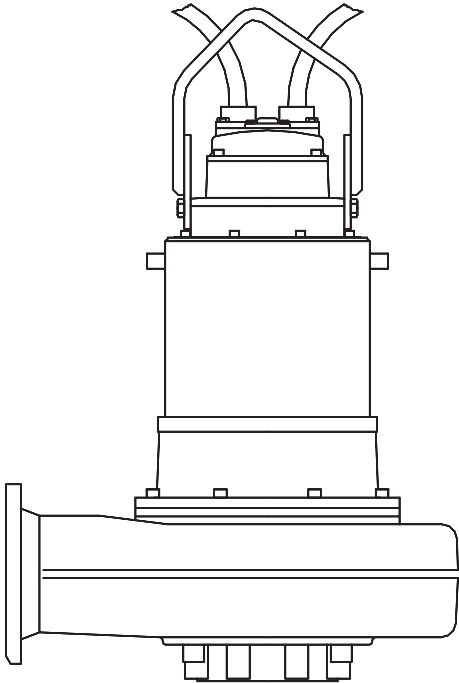

Weight, kg (with cooling jacket)	CP	CS	CT/CZ
LT	671	786	917
MT	570	598	635
HT	525	535	530

• Can be equipped with flush valve

CP/CT/CS

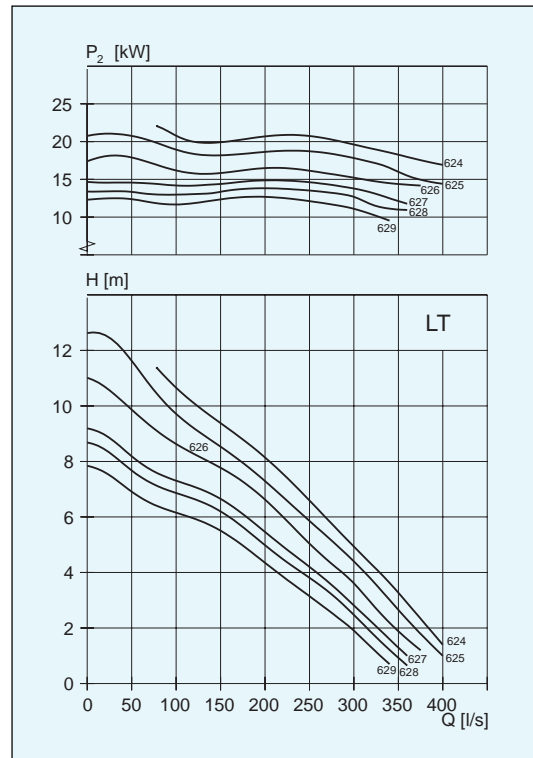

Impeller code	No. of vanes	Outlet dia mm CP vers.	Through-let, mm	Motor rating kW		rpm	Available versions
				P ₁	P ₂		
W•624	3	300/350	102 x 102	25	22	970	CP/CS/CT/CZ
W•625	3	300/350	102 x 102	25	22	970	CP/CS/CT/CZ
W•626	3	300/350	102 x 102	25	22	970	CP/CS/CT/CZ
W•627	3	300/350	102 x 102	25	22	970	CP/CS/CT/CZ
W•628	3	300/350	102 x 102	25	22	970	CP/CS/CT/CZ
W•629	3	300/350	102 x 102	25	22	970	CP/CS/CT/CZ

CP/CS/CT/CZ

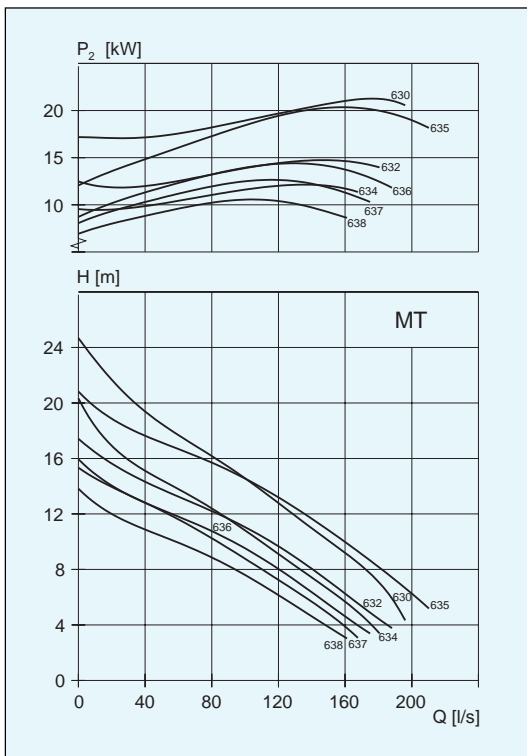

Impeller code	No. of vanes	Outlet dia mm CP vers.	Through-let, mm	Motor rating kW		rpm	Available versions
				P ₁	P ₂		
W•630	1	250	144 x 120	25	22	970	CP/CS/CT/CZ
W•632	1	250	144 x 120	25	22	970	CP/CS/CT/CZ
W•634	1	250	144 x 120	25	22	970	CP/CS/CT/CZ
W•635	2	250	102 x 84	25	22	970	CP/CS/CT/CZ
W•636	2	250	102 x 84	25	22	970	CP/CS/CT/CZ
W•637	2	250	102 x 84	25	22	970	CP/CS/CT/CZ
W•638	2	250	102 x 84	25	22	970	CP/CS/CT/CZ

CP/CS/CT/CZ

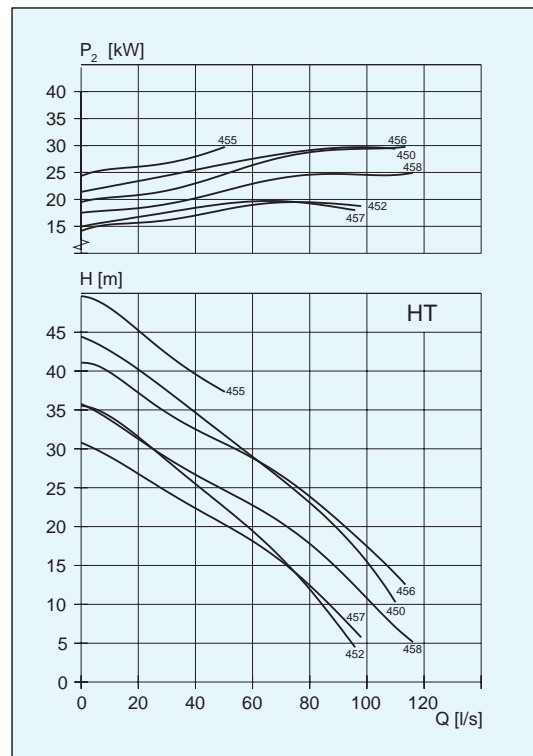

Impeller code	No. of vanes	Outlet dia mm CP vers.	Through-let, mm	Motor rating kW		rpm	Available versions
				P ₁	P ₂		
•450	1	200	77 x 80	34	30	1455	CP/CS/CT/CZ
W•452	1	200	77 x 77	34	30	1455	CP/CS/CT/CZ
•452	1	200	77 x 77	25	22	1460	CP/CS/CT/CZ
•455	1	200	∅ 100	34	30	1455	CP/CS/CT/CZ
•456	1	200	∅ 100	34	30	1455	CP/CS/CT/CZ
W•457	1	200	∅ 100	34	30	1455	CP/CS/CT/CZ
•457	1	200	∅ 100	25	22	1460	CP/CS/CT/CZ
W•458	1	200	∅ 100	34	30	1455	CP/CS/CT/CZ
•458	1	200	∅ 100	25	22	1460	CP/CS/CT/CZ

C 3201 SH

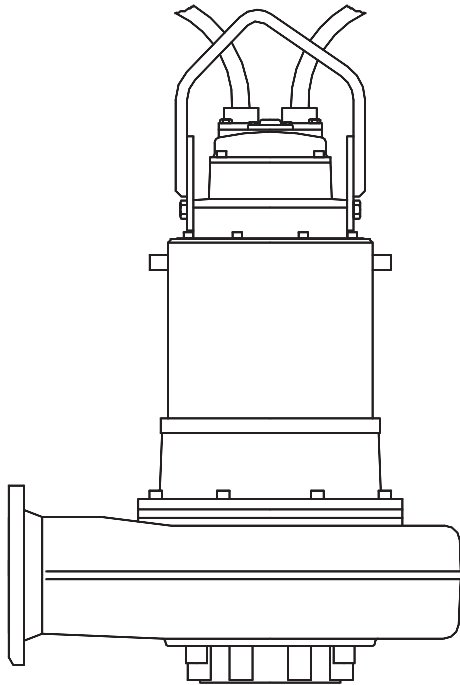

Weight, kg (with cooling jacket)	CP	CS	CT/CZ
SH	490	489	538

CP/CS/CT/CZ

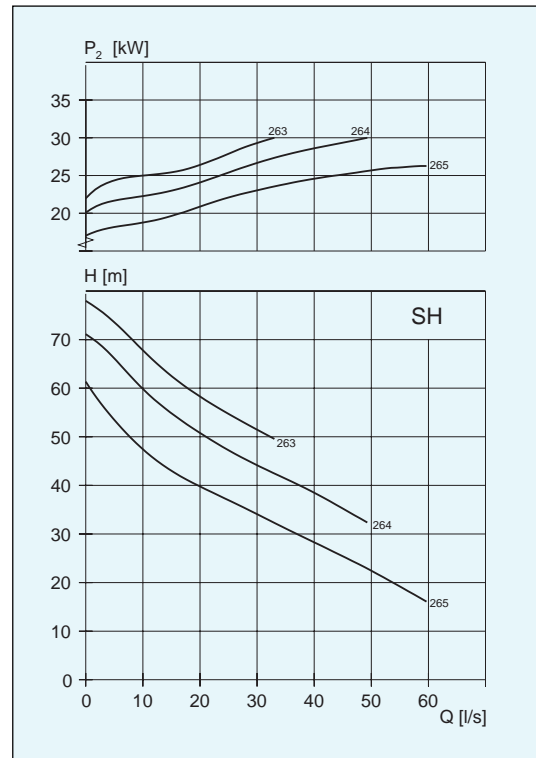

Impeller code	No. of vanes	Outlet dia mm CP vers.	Through-let, mm	Motor rating kW		rpm	Available versions
				P_1	P_2		
•263 *	1	100	∅76	34	30	2300	CP/CS/CT/CZ
•264 *	1	100	∅76	34	30	2300	CP/CS/CT/CZ
•265 ¹⁾	1	100	∅76	34	30	2300	CP/CS/CT/CZ

¹⁾ NPSH_{re} = 11 m at 51 l/s

- Can be equipped with flush valve
- * NEVACLOG

C 3300

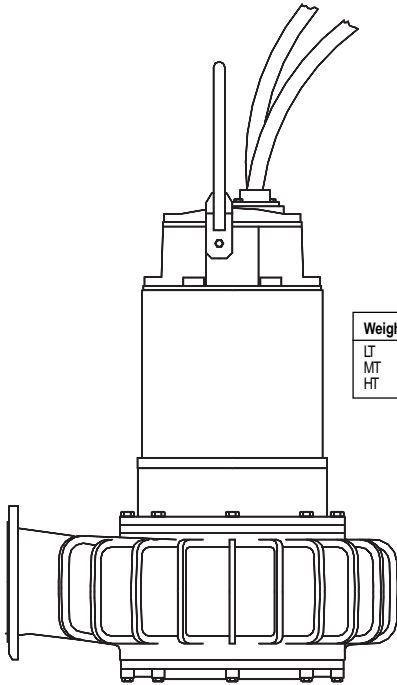

Weight, kg	CP	CS	CT/CZ
LT	1060	1175	1308
MT	1075	1188	1321
HT	900	963	1022

CP/CS/CT/CZ

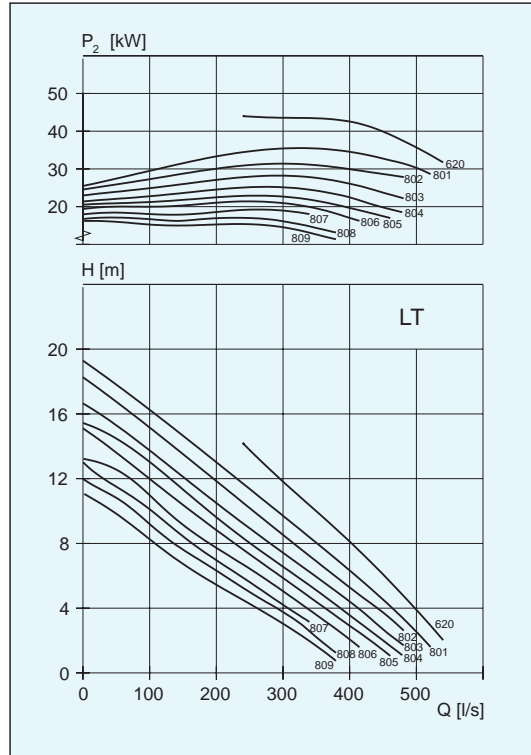

Impeller code	No. of vanes	Outlet dia mm CP vers.	Through-let, mm	Motor rating kW		rpm	Available versions
				P ₁	P ₂		
• 801-809	3	350	102 x 102	43	37	730	CP/CS/CT/CZ
• 804-809	3	350	102 x 102	31	27	730	CP/CS/CT/CZ
• 620	3	350	102 x 102	50	44	975	CP/CS/CT/CZ

CP/CS/CT/CZ

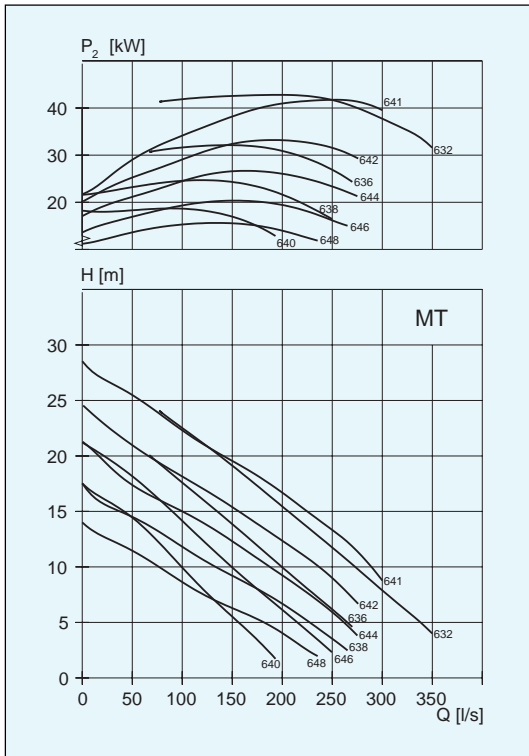

Impeller code	No. of vanes	Outlet dia mm CP vers.	Through-let, mm	Motor rating kW		rpm	Available versions
				P ₁	P ₂		
• 632	1	300	∅ 190	50	44	975	CP/CS/CT/CZ
• 636	1	300	176 x 100	50	44	975	CP/CS/CT/CZ
• 636	1	300	176 x 180	39	34	975	CP/CS/CT/CZ
• 638	1	300	150 x 100	50	44	975	CP/CS/CT/CZ
• 638	1	300	150 x 180	39	34	975	CP/CS/CT/CZ
• 640	1	300	134 x 100	50	44	975	CP/CS/CT/CZ
• 640	1	300	134 x 180	39	34	975	CP/CS/CT/CZ
• 641	2	300	100 x 100	50	44	975	CP/CS/CT/CZ
• 642	2	300	100 x 100	50	44	975	CP/CS/CT/CZ
• 642	2	300	100 x 100	39	34	975	CP/CS/CT/CZ
• 644	2	300	100 x 100	50	44	975	CP/CS/CT/CZ
• 644	2	300	100 x 100	39	34	975	CP/CS/CT/CZ
• 646	2	300	100 x 100	50	44	975	CP/CS/CT/CZ
• 646	2	300	100 x 100	39	34	975	CP/CS/CT/CZ
• 648	2	300	100 x 100	50	44	975	CP/CS/CT/CZ
• 648	2	300	100 x 100	39	34	975	CP/CS/CT/CZ

CP/CS/CT/CZ

• Can be equipped with flush valve

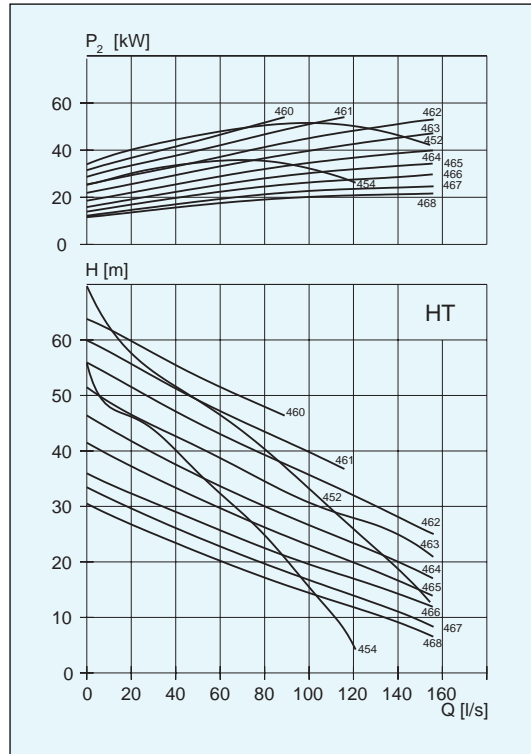

Impeller code	No. of vanes	Outlet dia mm CP vers.	Through-let, mm	Motor rating kW		rpm	Available versions
				P ₁	P ₂		
• 452	1	200	90 x 96	60	54	1475	CP/CS/CT/CZ
• 454	1	200	76 x 90	60	54	1475	CP/CS/CT/CZ
• 454	1	200	76 x 90	45	40	1475	CP/CS/CT/CZ
• 460-463	2	200	76 x 76	60	54	1475	CP/CS/CT/CZ
• 464-468	2	200	76 x 76	60	54	1475	CP/CS/CT/CZ
• 464-468	2	200	76 x 76	45	40	1475	CP/CS/CT/CZ

C- AND R-PUMPS • 50 Hz

LARGE SIZE

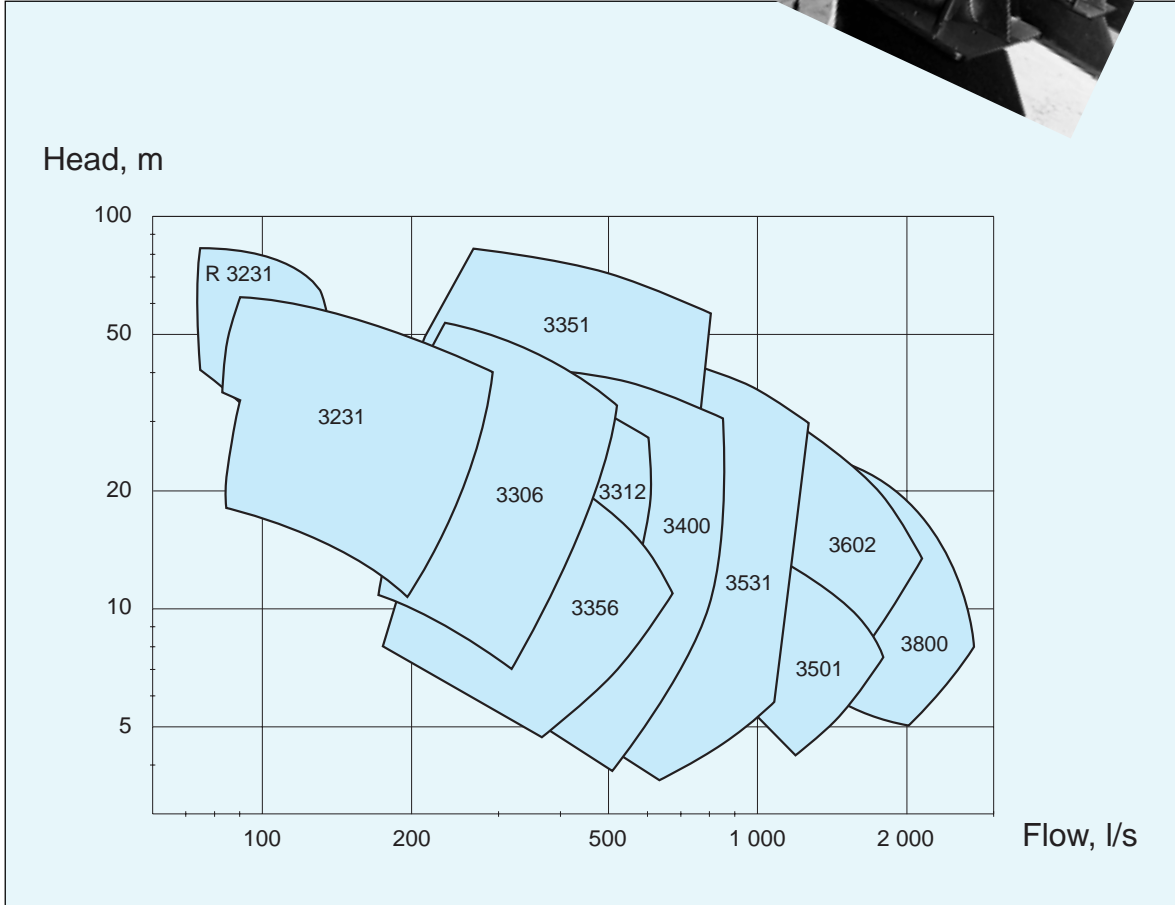
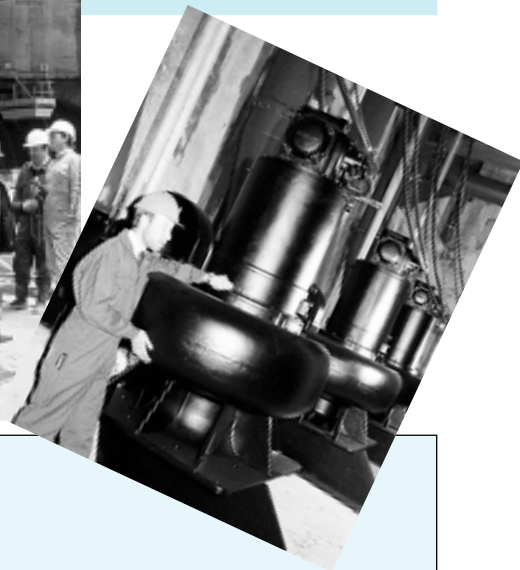

The C-pumps are equipped with shrouded multi-channel impellers running in a volute. The shape and the size of the channel minimize clogging, and therefore make the pump ideal for waste water containing large solid particles.



CP/CS/CT/CZ

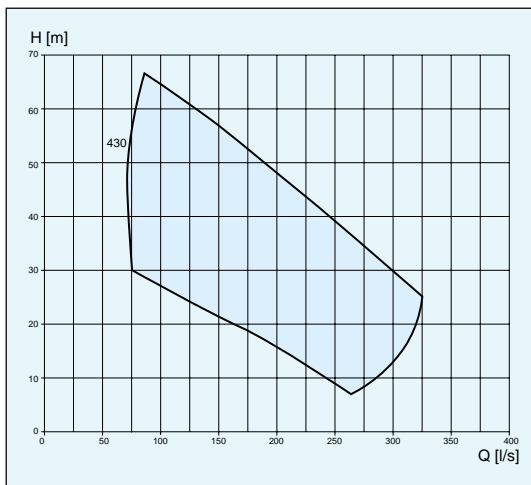

Impeller code	No. of vanes	Outlet dia mm CP vers.	Through-let, mm	Motor rating kW		rpm	Available versions
				P ₁	P ₂		
430	2	200	∅ 88	76-181	70-170	1485	CP/CS/CT/CZ

3231

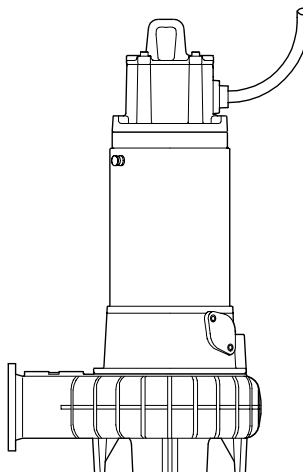

	CP	CS	CT	CZ
Max weight, kg	1820	1910	1730	1730

CP/CS/CT/CZ

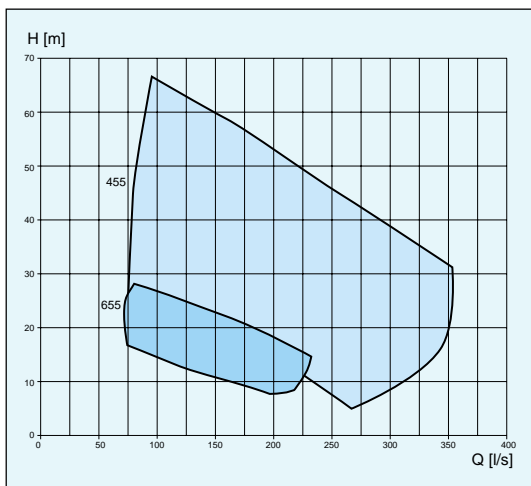

Impeller code	No. of vanes	Outlet dia mm CP vers.	Through-let, mm	Motor rating kW		rpm	Available versions
				P ₁	P ₂		
455	2	200	∅ 102	76-181	70-170	1485	CP/CS/CT/CZ
655	2	200	∅ 102	64	58	985	CP/CS/CT/CZ

RP/RT

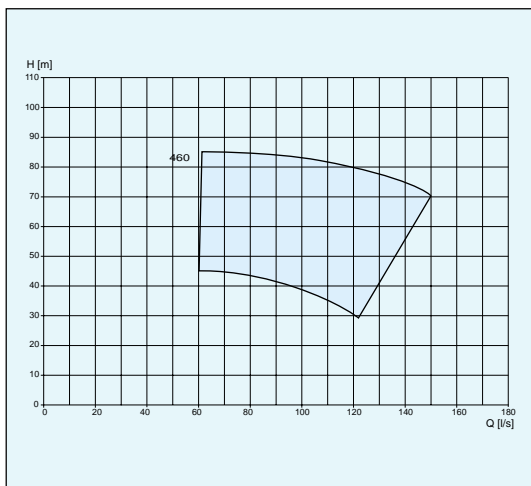

Impeller code	No. of vanes	Outlet dia mm RP vers.	Through-let, mm	Motor rating kW		rpm	Available versions
				P ₁	P ₂		
460	6	150	∅ 24	76-181	70-170	1485	RP/RT

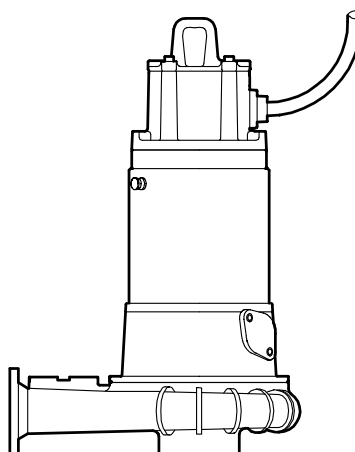

	RP	RT
Max weight, kg	1650	1620

RP/RT

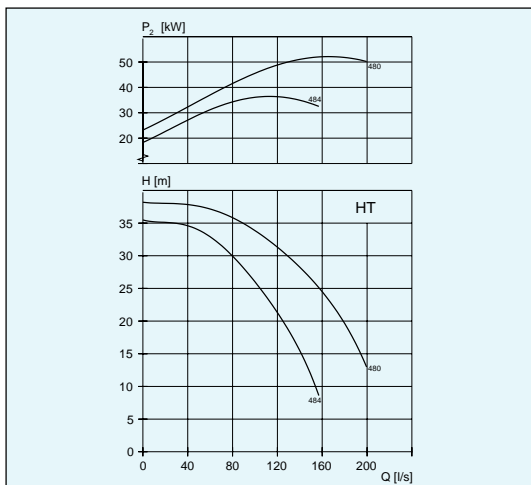

Impeller code	No. of vanes	Outlet dia mm	Through-let, mm	Motor rating kW		rpm	Available versions
				P ₁	P ₂		
480	6	150	37 x 37	45	40	1475	RP/RT
484	6	150	32 x 32	60	54	1475	RP/RT

R 3300

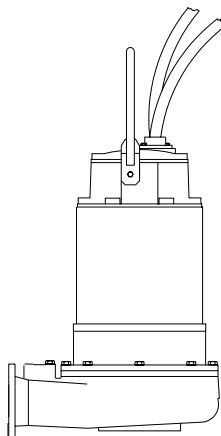

	RP	RT
Max weight, kg	820	943

CP/CS/CT/CZ

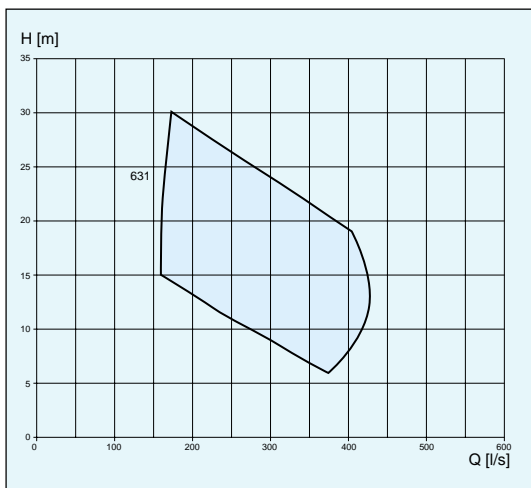

Impeller code	No. of vanes	Outlet dia mm CP vers.	Through-let, mm	Motor rating kW		rpm	Available versions
				P ₁	P ₂		
631	3	300	∅ 104	64-150	58-140	985	CP/CSCT/CZ

3306

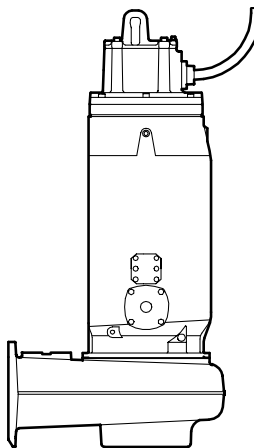

	CP	CS	CT	CZ
Max weight, kg	1920	2005	1820	1820

CP/CS/CT/CZ

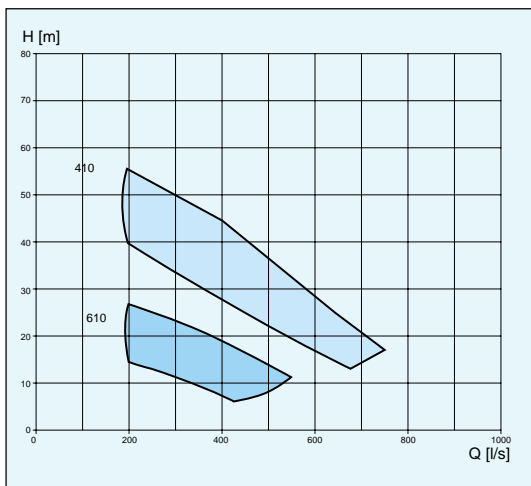

Impeller code	No. of vanes	Outlet dia mm CP vers.	Through-let, mm	Motor rating kW		rpm	Available versions
				P ₁	P ₂		
410	3	300	∅ 104	181-228	170-215	1480	CP/CSCT/CZ
610	3	300	∅ 104	64-150	58-140	985	CP/CSCT/CZ

CP/CS/CT/CZ

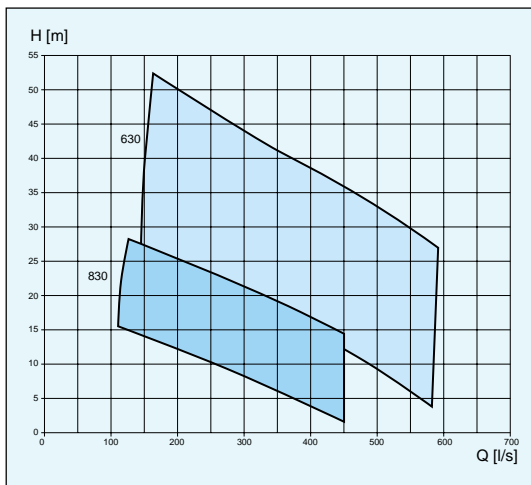

Impeller code	No. of vanes	Outlet dia mm CP vers.	Through-let, mm	Motor rating kW		rpm	Available versions
				P ₁	P ₂		
630	3	300	∅ 102	109-265	100-250	990	CP/CS/CT/CZ
830	3	300	∅ 102	61-100	55-90	735	CP/CS/CT/CZ

3312

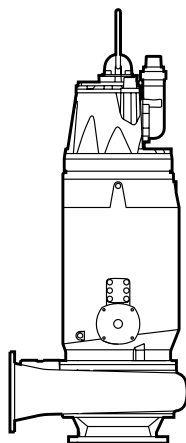

	CP	CS	CT	CZ
Max weight, kg	3150	3325	3050	3050

CP/CT/CZ

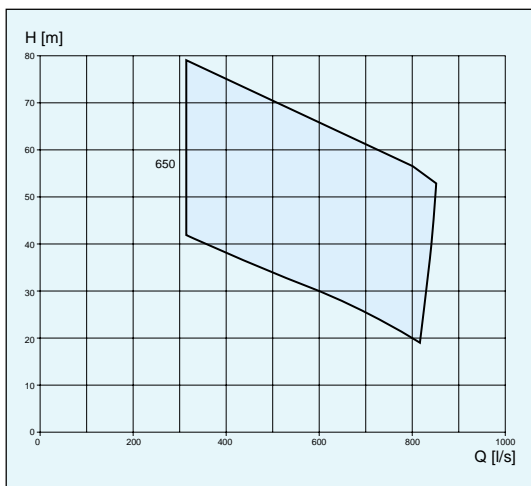

Impeller code	No. of vanes	Outlet dia mm CP vers.	Through-let, mm	Motor rating kW		rpm	Available versions
				P ₁	P ₂		
650	2	350	∅ 110	305-583	290-560	995	CP/CT/CZ

3351

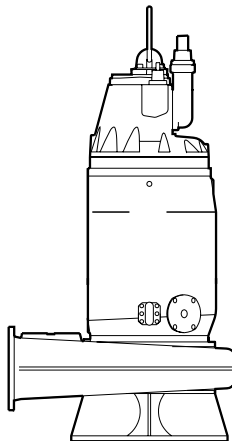

	CP	CT	CZ
Max weight, kg	5500	5520	5250

CP/CT/CZ

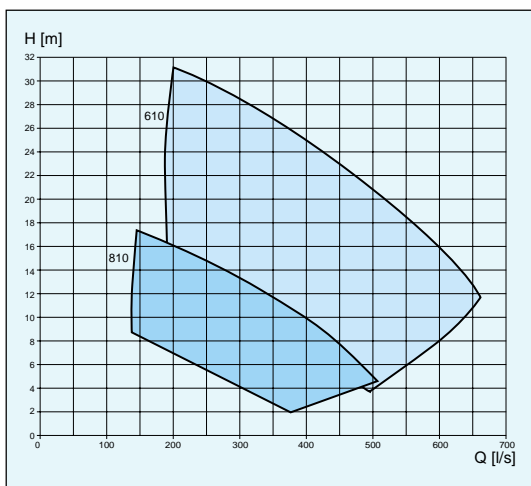

Impeller code	No. of vanes	Outlet dia mm CP vers.	Through-let, mm	Motor rating kW		rpm	Available versions
				P ₁	P ₂		
610	3	350	∅ 102	64-150	58-140	990	CP/CT/CZ
810	3	350	∅ 102	51-61	45-55	735	CP/CT/CZ

3356

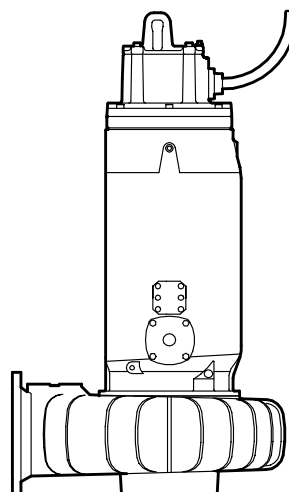

	CP	CT	CZ
Max weight, kg	2050	1950	1950

CP/CT/CZ

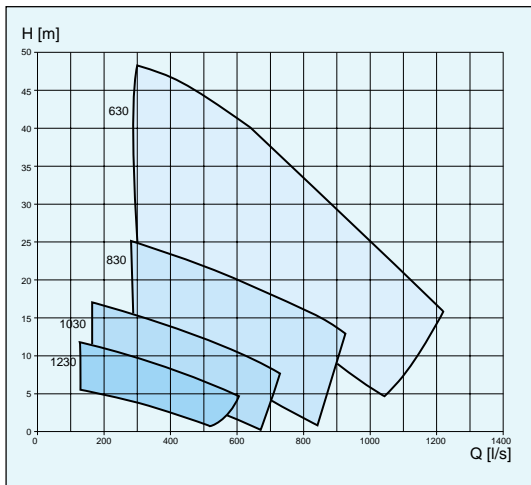

Impeller code	No. of vanes	Outlet dia mm CP vers.	Through-let, mm	Motor rating kW		rpm	Available versions
				P ₁	P ₂		
630	3	400	110	191-327	180-310	990	CP/CT/CZ
830	3	400	110	100-172	90-160	735	CP/CT/CZ
1030	3	400	110	44-99	40-90	585	CP/CT/CZ
1230	3	400	110	34-45	30-40	490	CP/CT/CZ

3400

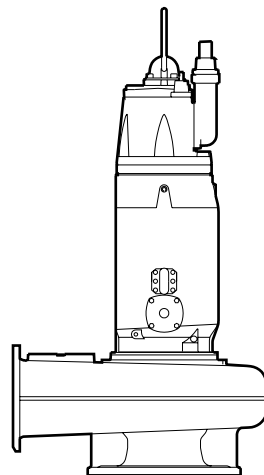

	CP	CT	CZ
Max weight, kg	3850	3700	3700

CP/CT/CZ

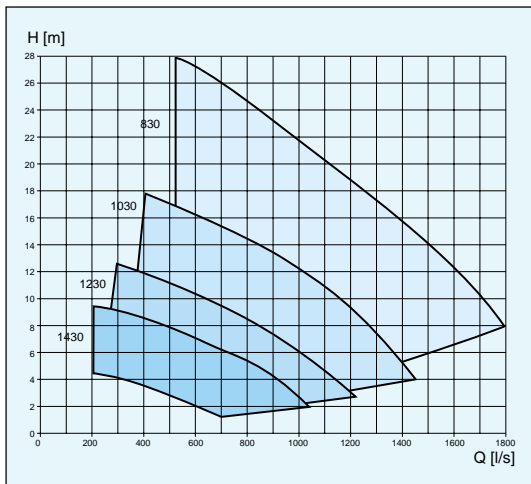

Impeller code	No. of vanes	Outlet dia mm CP vers.	Through-let, mm	Motor rating kW		rpm	Available versions
				P ₁	P ₂		
830	3	500	∅ 110	164-293	150-275	740	CP/CT/CZ
1030	3	500	∅ 110	99-183	90-170	590	CP/CT/CZ
1230	3	500	∅ 110	45-109	40-100	490	CP/CT/CZ
1430	3	500	∅ 110	46-68	40-60	420	CP/CT/CZ

3501

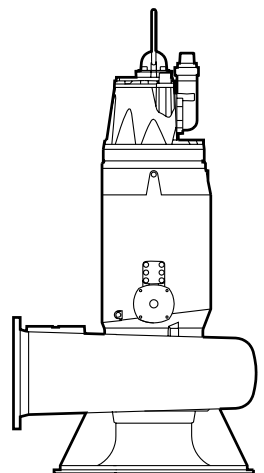

	CP	CT	CZ
Max weight, kg	4330	4100	4100

CP/CT/CZ

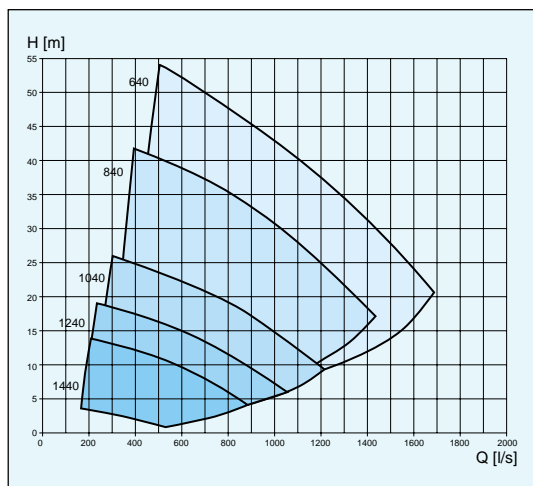

Impeller code	No. of vanes	Outlet dia mm CP vers.	Through-let, mm	Motor rating kW		rpm	Available versions
				P ₁	P ₂		
640	3	500	∅ 105	265-583	250-560	995	CP/CT/CZ
840	3	500	∅ 105	137-417	125-400	745	CP/CT/CZ
1040	3	500	∅ 105	67-231	60-215	590	CP/CT/CZ
1240	3	500	∅ 105	45-152	40-140	495	CP/CT/CZ
1440	3	500	∅ 105	46-79	40-70	420	CP/CT/CZ

3531

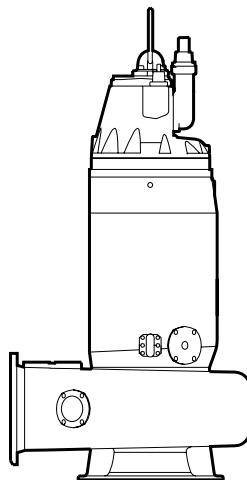

	CP	CT	CZ
Max weight, kg	5500	5300	5300

CP/CT/CZ

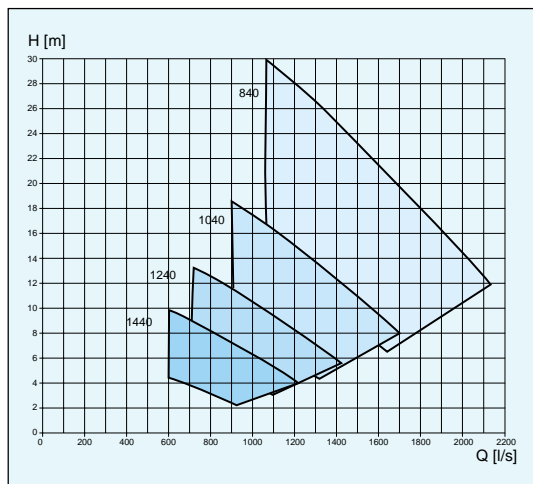

Impeller code	No. of vanes	Outlet dia mm CP vers.	Through-let, mm	Motor rating kW		rpm	Available versions
				P ₁	P ₂		
840	4	600	∅ 126	230-479	215-460	745	CP/CT/CZ
1040	4	600	∅ 126	121-264	110-250	595	CP/CT/CZ
1240	4	600	∅ 126	67-152	60-140	495	CP/CT/CZ
1440	4	600	∅ 126	68-88	60-80	420	CP/CT/CZ

3602

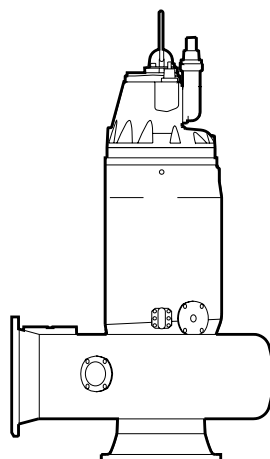

	CP	CT	CZ
Max weight, kg	6200	5950	5950

CP/CT/CZ

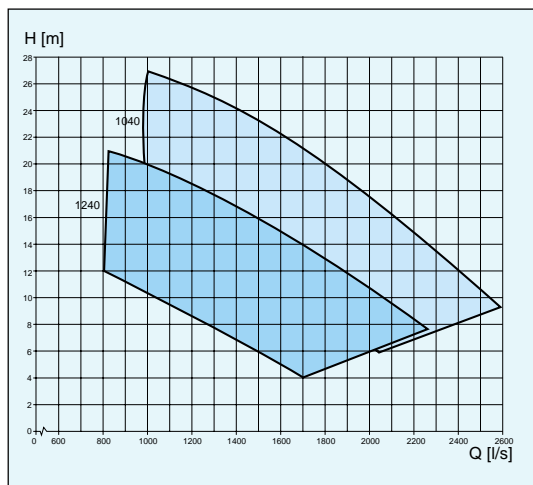

Impeller code	No. of vanes	Outlet dia mm CP vers.	Through-let, mm	Motor rating kW		rpm	Available versions
				P ₁	P ₂		
1040	4	800	∅ 140	342-473	325-450	595	CP/CT/CZ
1240	4	800	∅ 140	241-345	225-325	495	CP/CT/CZ

3800

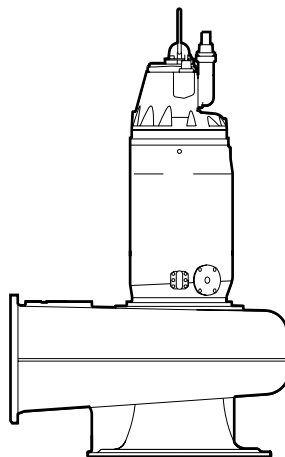

	CP	CT	CZ
Max weight, kg	9000	8600	8600

D-PUMPS • 50 Hz

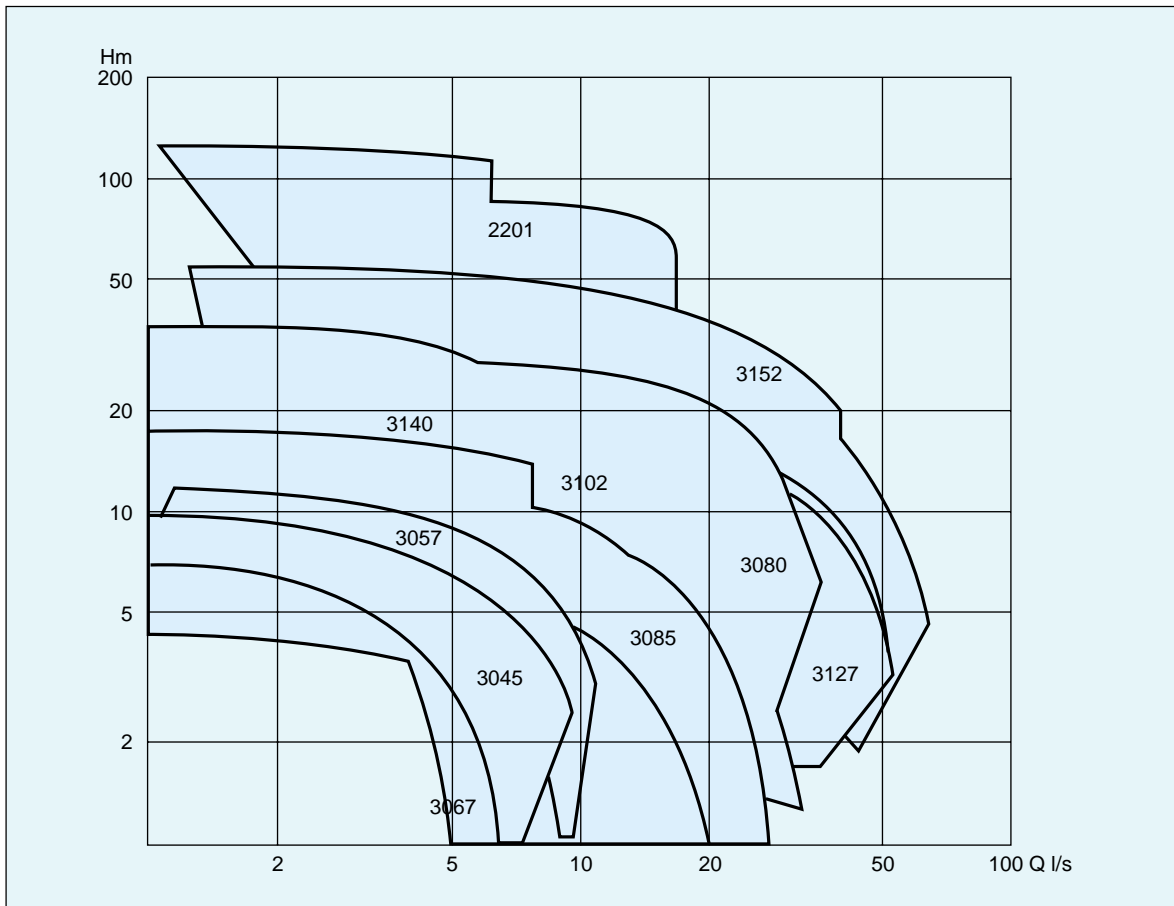

D-pumps are equipped with a vortex impeller in a volute. Pumping takes place by the impeller inducing a rapidly rotating vortex, with consequent pressure rise in the liquid.

As a result, most of the solid particles in the liquid never come into contact with the impeller, thereby minimizing wear.

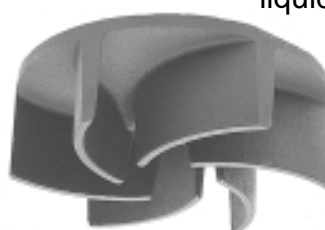

The throughlet area of a pump with a torque flow impeller is almost as large as the pump inlet.

D 2201

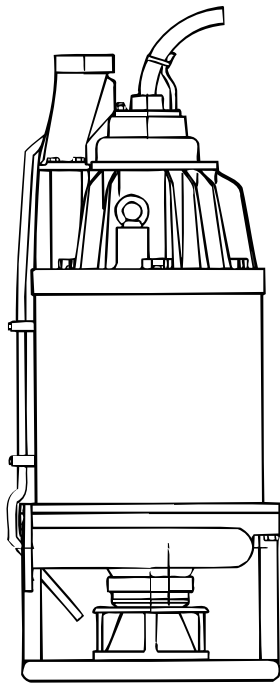

Pump type	DS
Weight, kg	415

DS

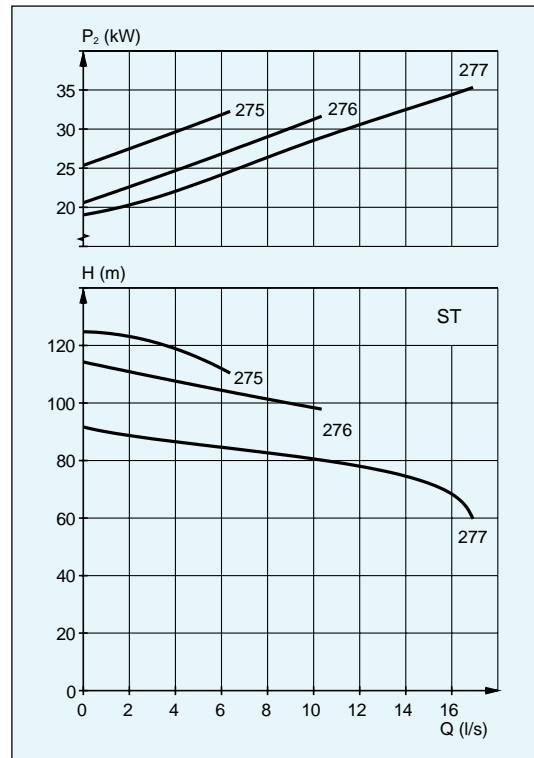

Impeller code	Outlet dia mm DP vers.	Through-let, mm	Motor rating kW		rpm	Available versions
			P ₁	P ₂		
275	40	10	41	37	2940	DS
276	40	10	41	37	2940	DS
277	40	10	41	37	2940	DS

D 3045

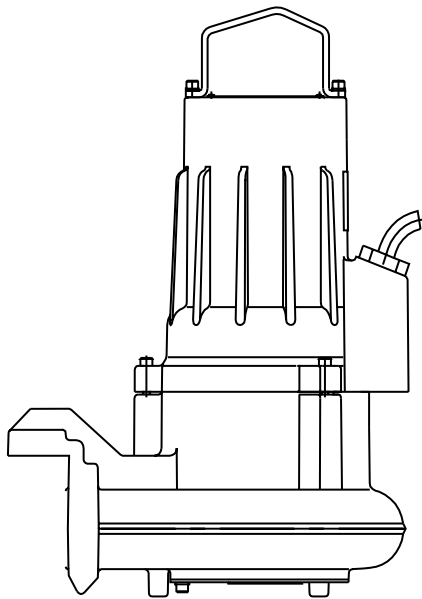

Pump type	DP	DF	DH	DS
Weight, kg	28	28	28	28

DP/DF/DH/DS

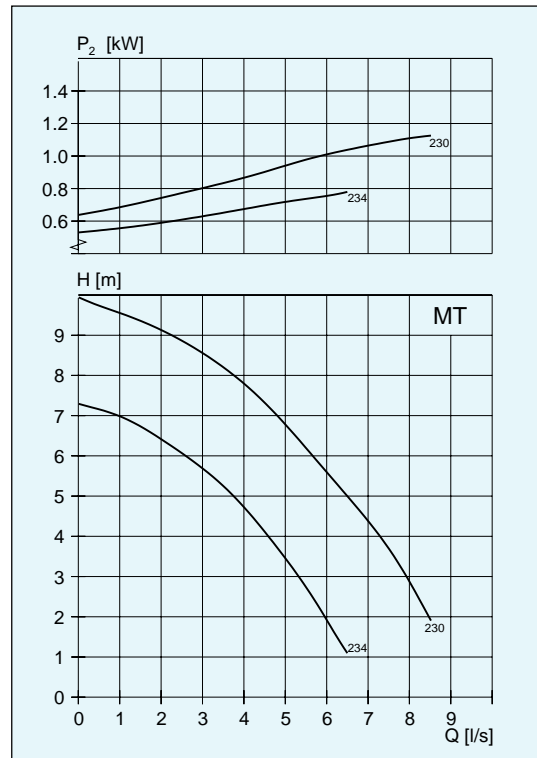

Impeller code	Outlet dia mm DP vers.	Through-let, mm	Motor rating kW		rpm	Available versions
			P_1	P_2		
230	50	48	1.5	1.2	2790	DP/DF/DHDS
234	50	48	1.5	1.2	2790	DP/DF/DHDS
234	50	48	1.0	0.8	2870	DP/DF/DHDS

DP/DF/DH/DS

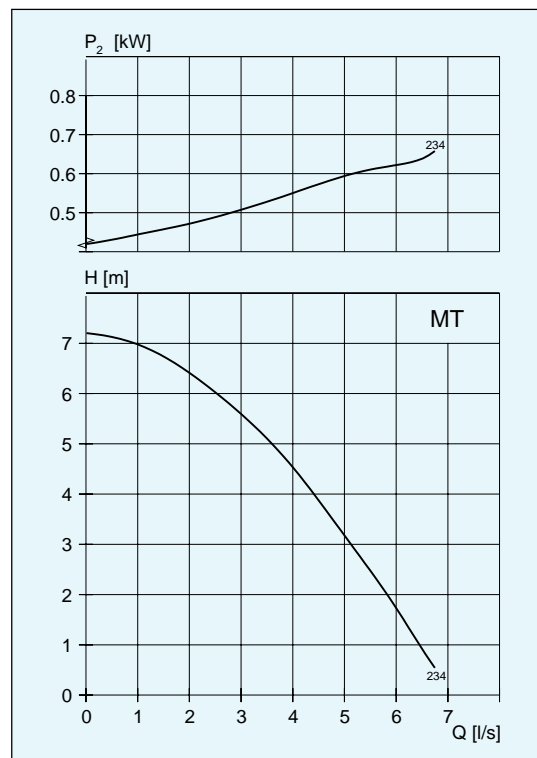

Impeller code	Outlet dia mm DP vers.	Through-let, mm	Motor rating kW		rpm	Available versions
			P_1	P_2		
234*	50	48	1.0	0.75	2750	DP/DF/DHDS

*Single phase

D 3057

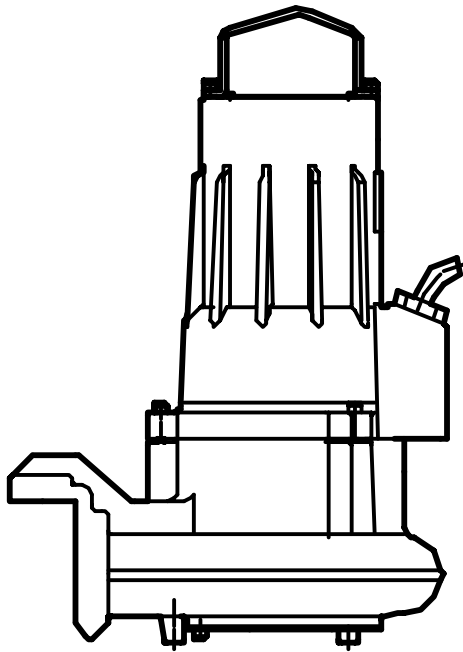

Pump type	DP	DS	DF
Weight, kg	31	31	31

DP/DS/DF

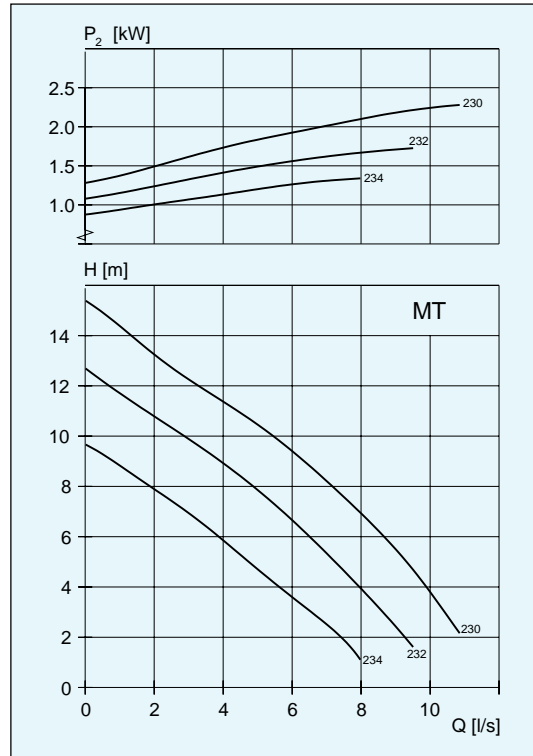

Impeller code	Outlet dia mm DP vers.	Through-let, mm	Motor rating kW		rpm	Available versions
			P_1	P_2		
W230	50	48	3.1	2.4	2695	DP/DS/DF
230	50	48	2.3	1.7	2695	DP/DS/DF
W232	50	48	3.1	2.4	2695	DP/DS/DF
232	50	48	2.3	1.7	2695	DP/DS/DF
W234	50	48	3.1	2.4	2695	DP/DS/DF
234	50	48	2.3	1.7	2695	DP/DS/DF

DP/DS/DF

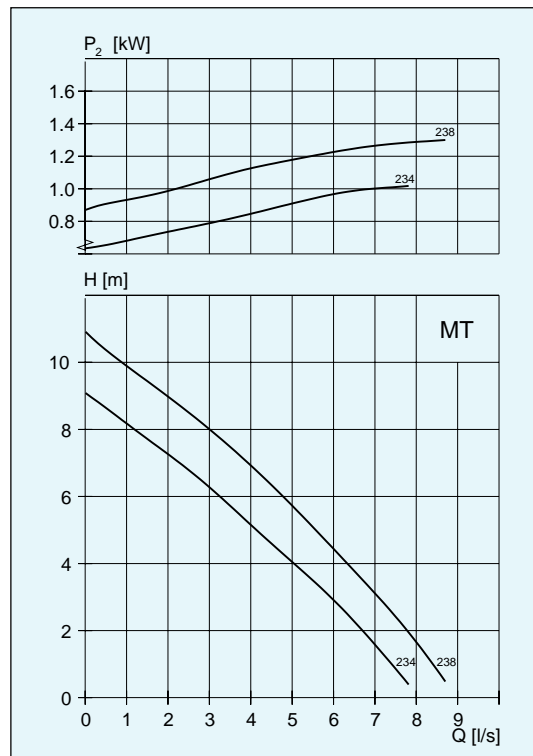

Impeller code	Outlet dia mm DP vers.	Through-let, mm	Motor rating kW		rpm	Available versions
			P_1	P_2		
234*	50	50	2.1	1.5	2695	DP/DS/DF
238*	50	50	2.1	1.5	2695	DP/DS/DF

* Single phase

D 3057

Abrasion resistant

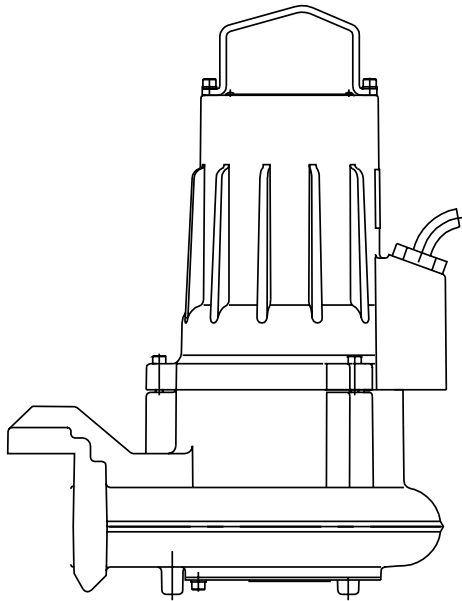

DP/DS/DF Abrasion resistant

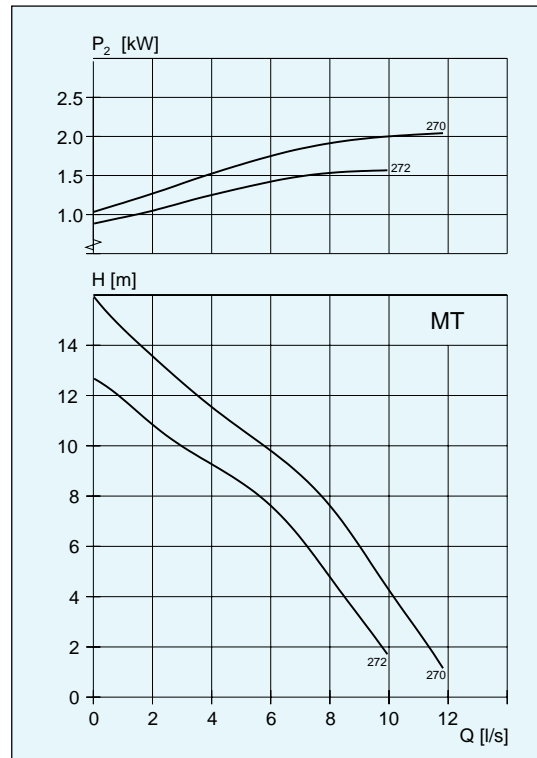

Impeller code	Outlet dia mm DP vers.	Through-let, mm	Motor rating kW		rpm	Available versions
			P_1	P_2		
270	50	24	3.1	2.4	2865	DP/DS/DF
272	50	24	3.1	2.4	2865	DP/DS/DF

D 3060

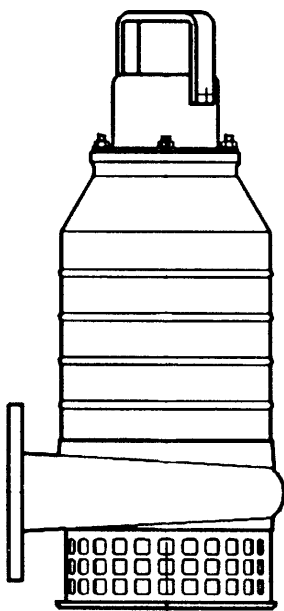

DP/DT/DS

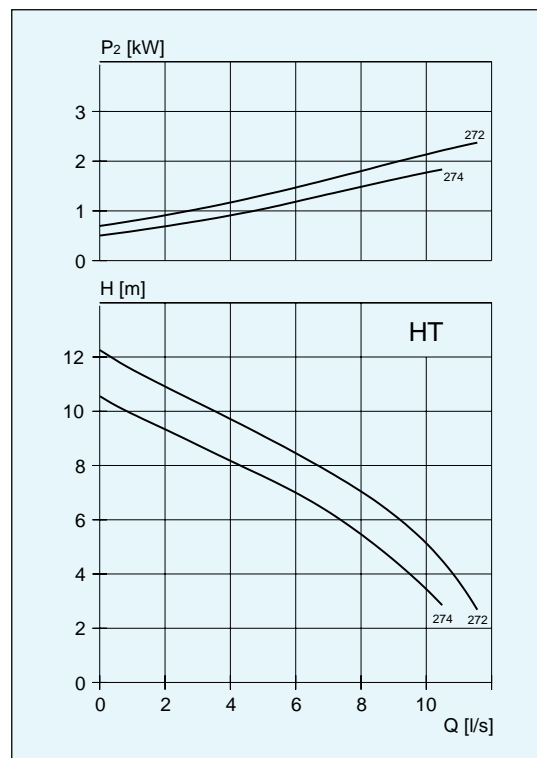

Pump type	DP	DS	DT
Weight, kg	41	41	45

Impeller code	Outlet dia mm, DP vers.	Through-let, mm	Motor rating kW		rpm	Available versions
			P_1	P_2		
272	75	15 x 15	3.3	2.4	2800	DP/DT/DS
274	75	15 x 15	3.3	2.4	2800	DP/DT/DS

D 3067

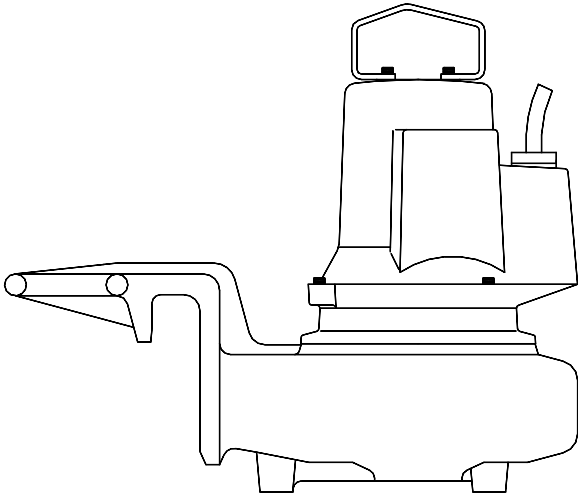

Pump type	DP	DS	DF
Weight, kg	41	49	47

DP/DS/DF

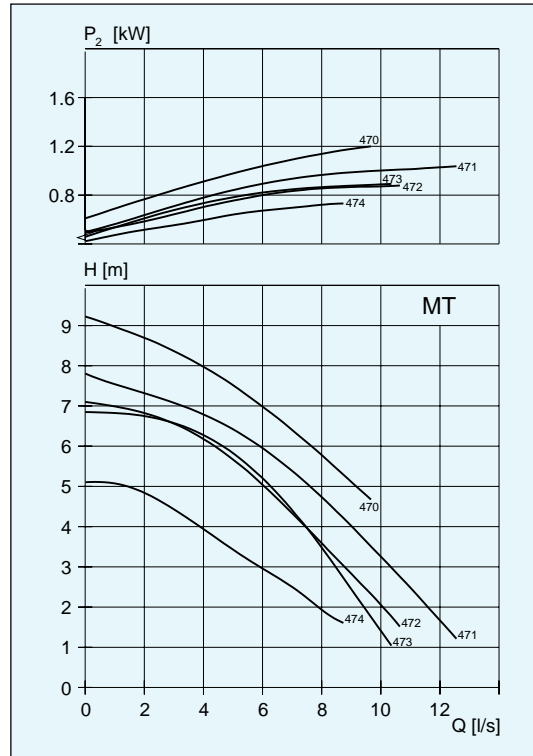

Impeller code	Outlet dia mm DP vers.	Through-let, mm	Motor rating kW		rpm	Available versions
			P ₁	P ₂		
W470	65	55 or 65	1.7	1.2	1345	DP/DS/DF
W471	65	55 or 65	1.7	1.2	1345	DP/DS/DF
W472	65	55 or 65	1.7	1.2	1345	DP/DS/DF
W473	65	55 or 65	1.7	1.2	1345	DP/DS/DF
W474	65	55 or 65	1.7	1.2	1345	DP/DS/DF
473*	65	55 or 65	1.3	0.8	1375	DP/DS/DF

* Single phase

DP/DS/DF

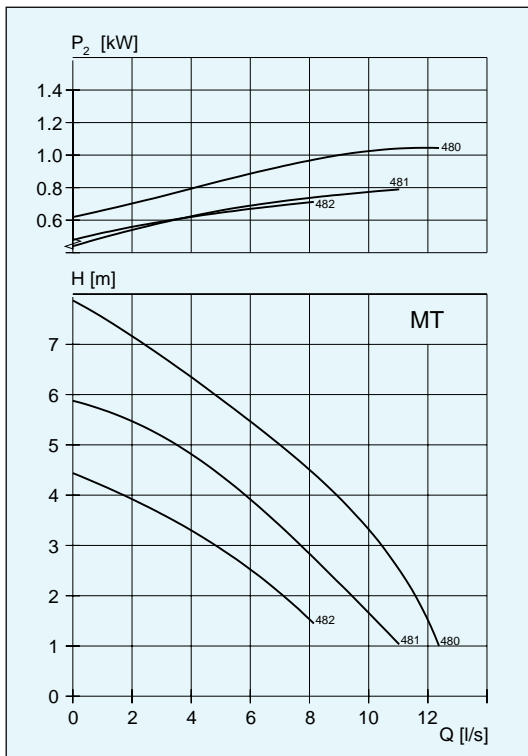

Impeller code	Outlet dia mm DP vers.	Through-let, mm	Motor rating kW		rpm	Available versions
			P ₁	P ₂		
W480	65	55 or 65	1.7	1.2	1345	DP/DS/DF
W481	65	55 or 65	1.7	1.2	1345	DP/DS/DF
W482	65	55 or 65	1.7	1.2	1345	DP/DS/DF
481*	65	55 or 65	1.3	0.8	1375	DP/DS/DF

* Single phase

DP/DS

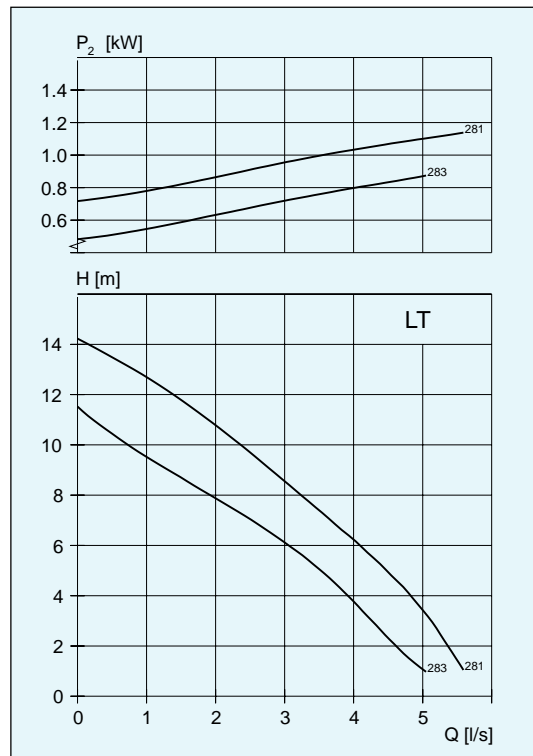

Impeller code	Outlet dia mm DP vers.	Through-let, mm	Motor rating kW		rpm	Available versions
			P ₁	P ₂		
W281	50	∅ 30	1.5	1.2	2770	DP/DS
W283	50	∅ 30	1.5	1.2	2820	DP/DS
283*	50	∅ 30	1.3	0.9	2815	DP/DS

* Single phase

D 3080

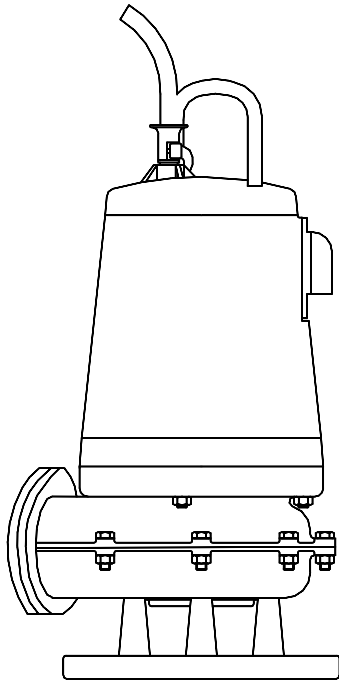

Weight, kg	DP	DS
Aluminium	60	60
Cast iron	100	100

DP/DS

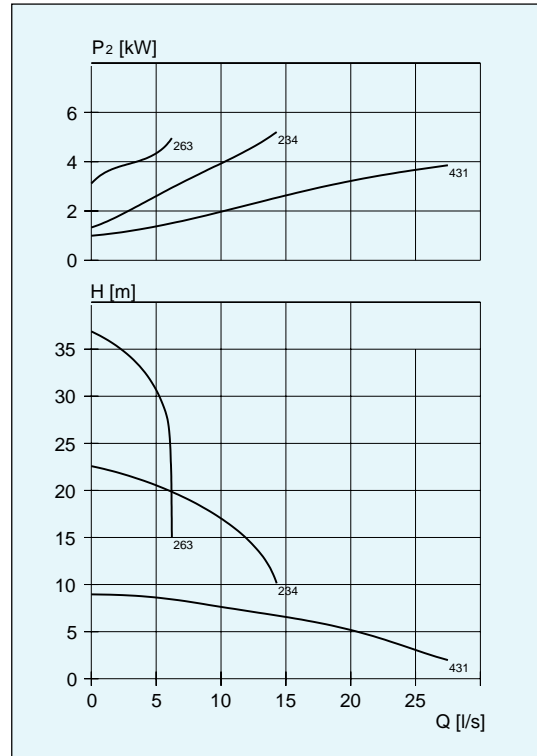

Impeller code	Outlet dia mm DP vers.	Through-let, mm	Motor rating kW		rpm	Available versions
			P ₁	P ₂		
263	75	46	7.3	5.5	2800	DPDS
234	75	46	7.3	5.5	2800	DPDS
431	100	80	5.8	3.8	1400	DPDS

D 3085

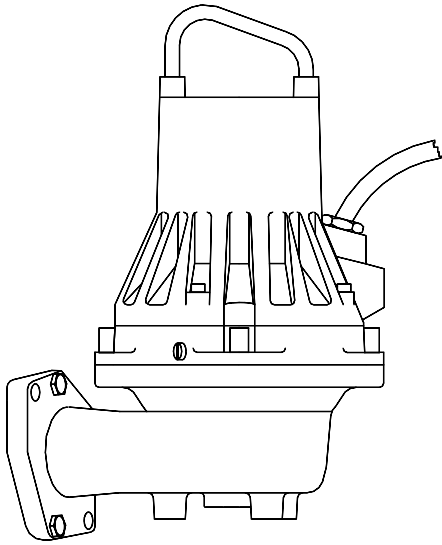

Weight, kg	DP	DS
MT	51	55
HT	51	55

• Can be equipped with flush valve

DP/DS

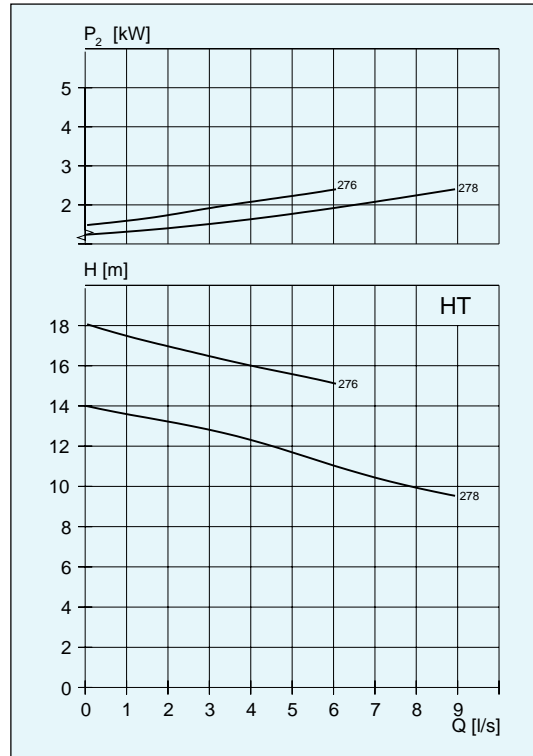

Impeller code	Outlet dia mm DP vers.	Through-let, mm	Motor rating kW		rpm	Available versions
			P ₁	P ₂		
276	80	∅52	3.0	2.4	2830	DP/DS
278	80	∅52	3.0	2.4	2830	DP/DS

DP/DS

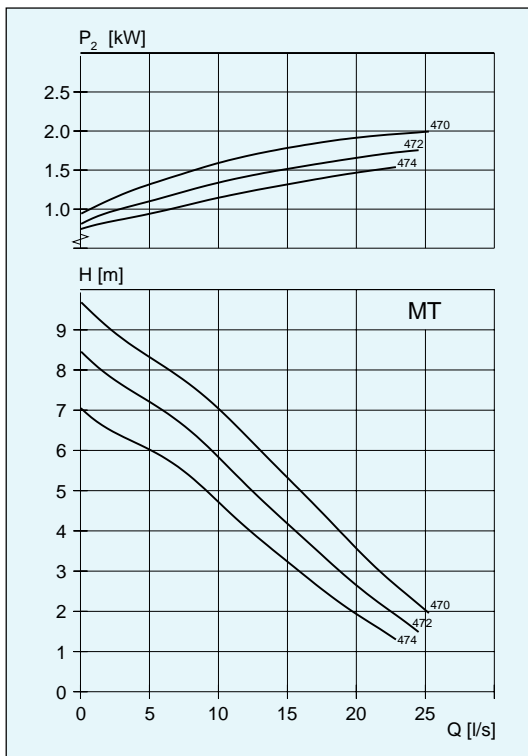

Impeller code	Outlet dia mm DP vers.	Through-let, mm	Motor rating kW		rpm	Available versions
			P ₁	P ₂		
•470	80	∅76	2.7	2.0	1395	DP/DS
•472	80	∅76	2.7	2.0	1395	DP/DS
•474	80	∅76	2.7	2.0	1395	DP/DS
•474*	80	∅76	1.8	1.3	1390	DP/DS
•472*	80	∅76	2.0	1.5	1440	DP/DS
•474*	80	∅76	2.0	1.5	1440	DP/DS

* Single phase

DP/DS Hardened cast iron

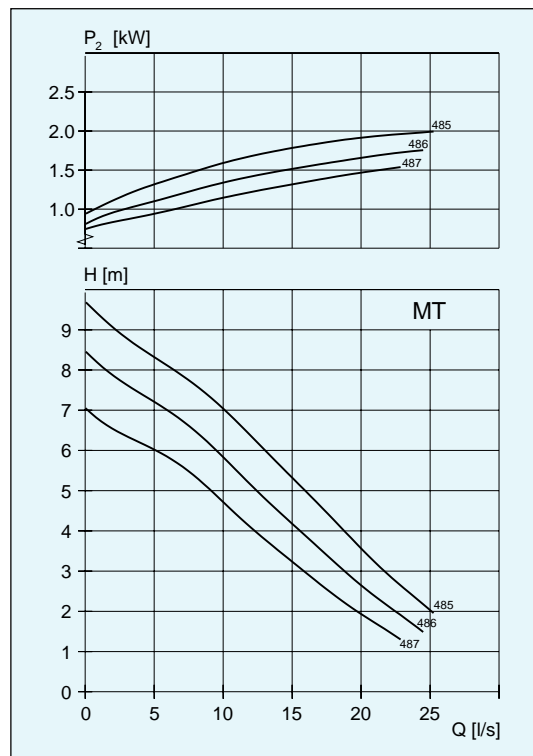

Impeller code	Outlet dia mm DP vers.	Through-let, mm	Motor rating kW		rpm	Available versions
			P ₁	P ₂		
•485	80	∅76	2.7	2.0	1395	DP/DS
•486	80	∅76	2.7	2.0	1395	DP/DS
•487	80	∅76	2.7	2.0	1395	DP/DS
•487*	80	∅76	1.8	1.3	1390	DP/DS
•486*	80	∅76	2.0	1.5	1440	DP/DS
•487*	80	∅76	2.0	1.5	1440	DP/DS

* Single phase

D 3102

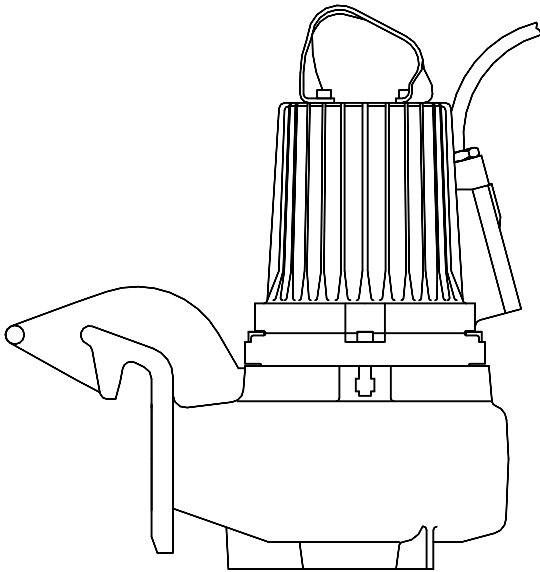

Weight, kg	DP
MT	105
HT	81

DP

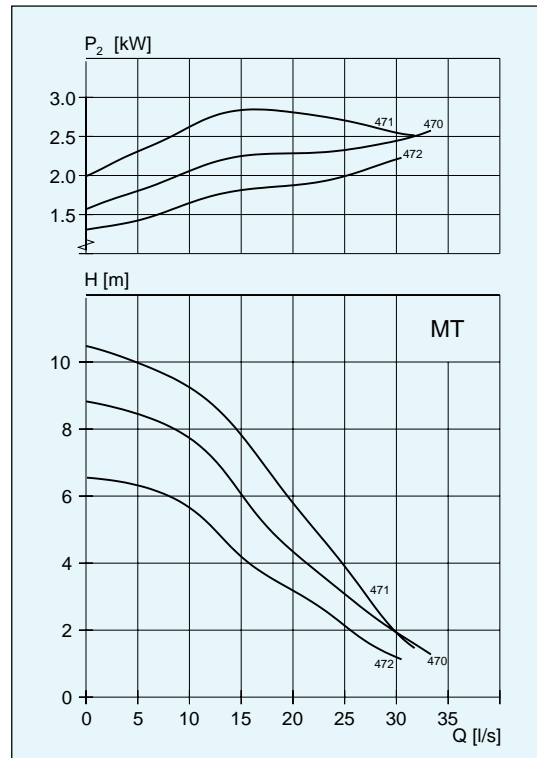

Impeller code	Outlet dia mm DP vers.	Through-let, mm	Motor rating kW		rpm	Available versions
			P ₁	P ₂		
VW•470	80	∅100	3.8	3.1	1435	DP
VW•471	80	∅100	3.8	3.1	1435	DP
VW•472	80	∅100	3.8	3.1	1435	DP

- Can be equipped with flush valve

DP

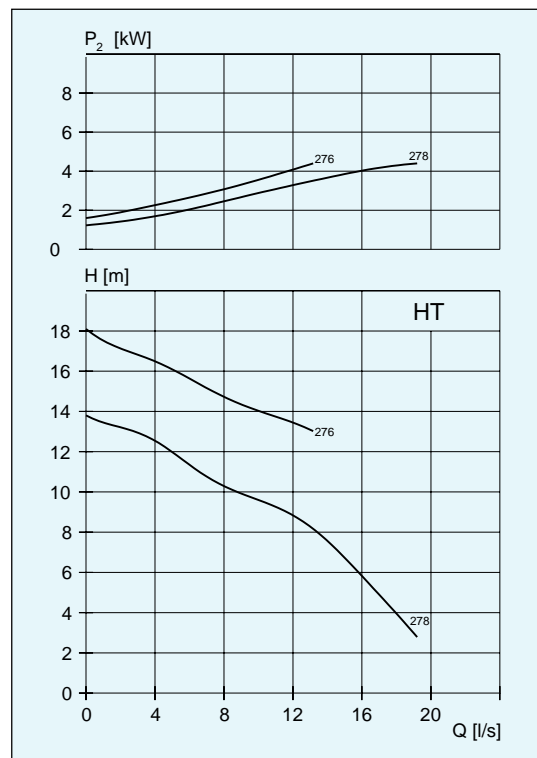

Impeller code	Outlet dia mm DP vers.	Through-let, mm	Motor rating kW		rpm	Available versions
			P ₁	P ₂		
276	80	∅52	5.4	4.4	2870	DP
278	80	∅52	5.4	4.4	2870	DP

D 3127

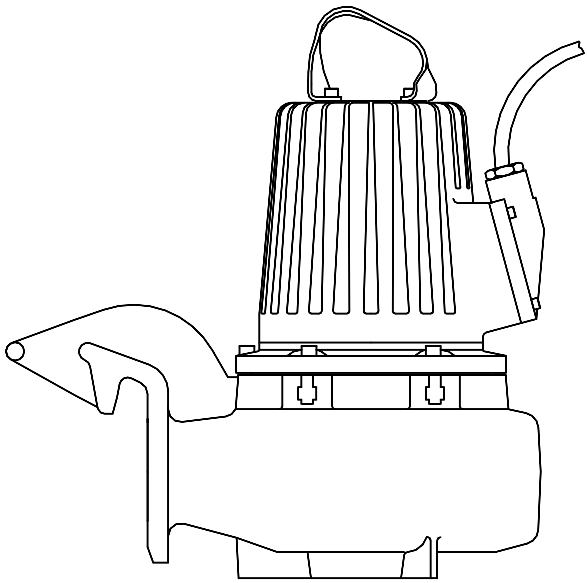

Weight, kg	DP
MT	127
HT	140

DP

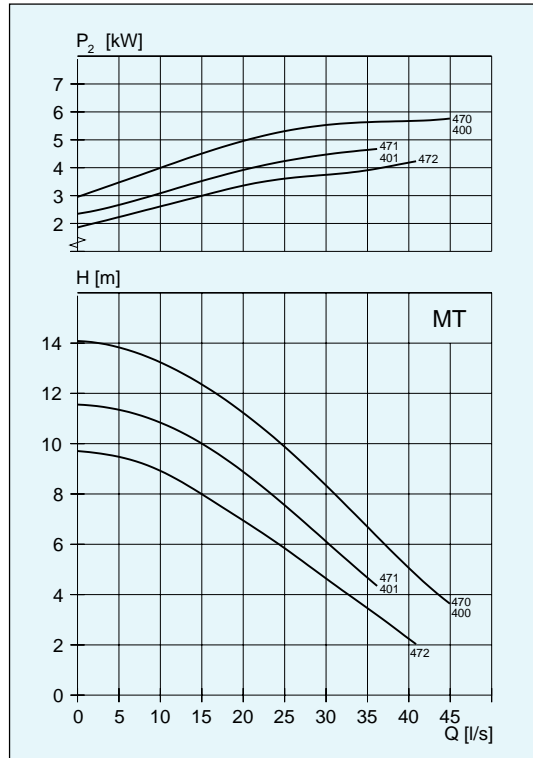

Impeller code	Outlet dia mm DP vers.	Through-let, mm	Motor rating kW		rpm	Available versions
			P ₁	P ₂		
W•400*	100	∅100	7.1	5.9	1450	DP
W•401*	100	∅100	7.1	5.9	1450	DP
•401*	100	∅100	5.7	4.7	1460	DP
W•470	100	∅100	7.1	5.9	1450	DP
W•471	100	∅100	7.1	5.9	1450	DP
•471	100	∅100	5.7	4.7	1460	DP
W•472	100	∅100	7.1	5.9	1450	DP
•472	100	∅100	5.7	4.7	1460	DP

- Can be equipped with flush valve
- * Hardened cast iron

DP

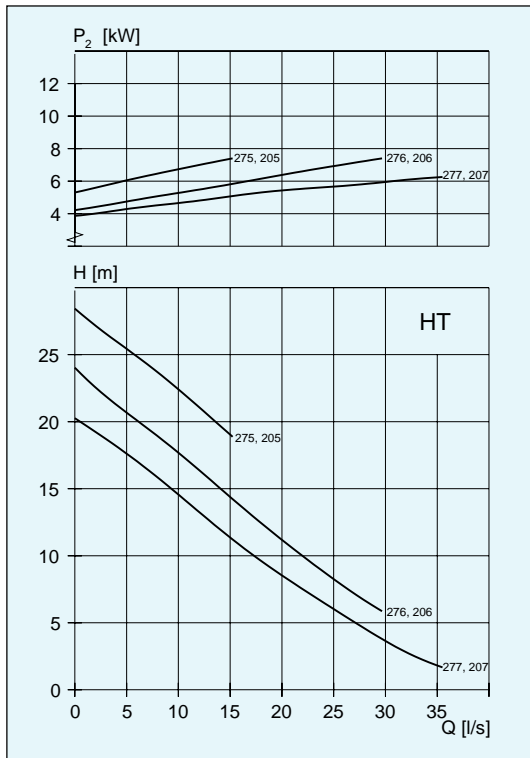

Impeller code	Outlet dia mm DP vers.	Through-let, mm	Motor rating kW		rpm	Available versions
			P ₁	P ₂		
•205*	78	∅76	8.7	7.4	2900	DP
•206*	78	∅76	8.7	7.4	2900	DP
•207*	78	∅76	8.7	7.4	2900	DP
•275	78	∅76	8.7	7.4	2900	DP
•276	78	∅76	8.7	7.4	2900	DP
•277	78	∅76	8.7	7.4	2900	DP

- Can be equipped with flush valve
- * Hardened cast iron

D 3140

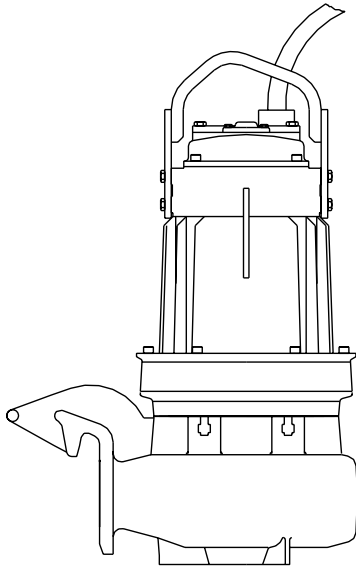

Pump type	DP
Weight, kg	216

DP

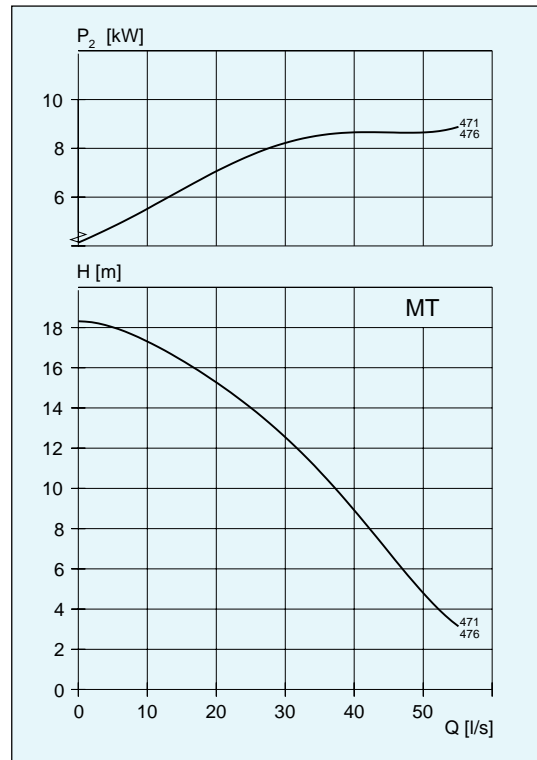

Impeller code	Outlet dia mm DP vers.	Through-let, mm	Motor rating kW		rpm	Available versions
			P_1	P_2		
•471	100	∅ 100	10.7	9	1450	DP
•476*	100	∅ 100	10.7	9	1450	DP

- Can be equipped with flush valve
- * Hardened cast iron

D 3152

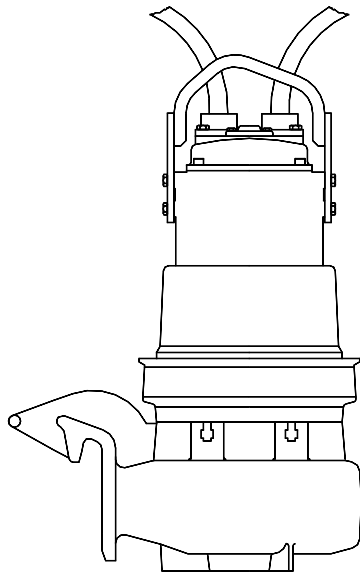

Weight, kg	DP
MT	263
HT	255

DP

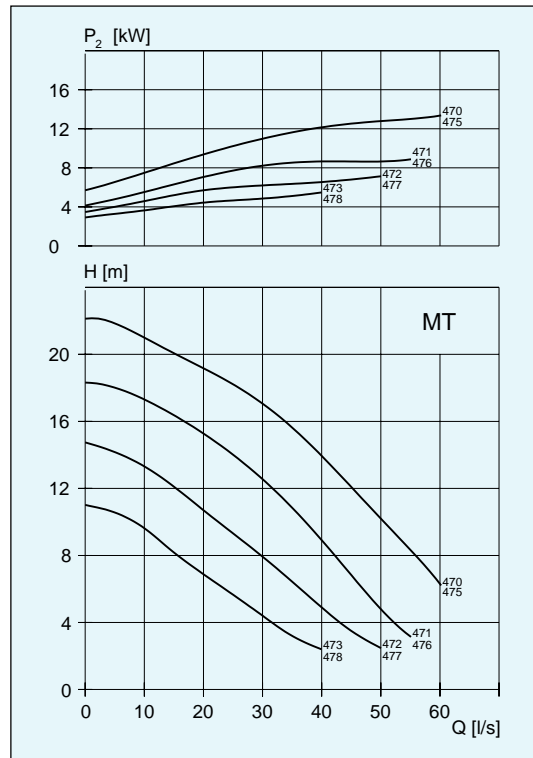

Impeller code	Outlet dia mm DP vers.	Through-let, mm	Motor rating kW		rpm	Available versions
			P ₁	P ₂		
W•470	100	∅100	15.8	13.5	1450	DP
W•471	100	∅100	15.8	13.5	1450	DP
•471	100	∅100	10.7	9	1455	DP
W•472	100	∅100	15.8	13.5	1450	DP
•472	100	∅100	10.7	9	1455	DP
W•473	100	∅100	15.8	13.5	1450	DP
•473	100	∅100	10.7	9	1455	DP
W•475*	100	∅100	15.8	13.5	1450	DP
W•476*	100	∅100	15.8	13.5	1450	DP
•476*	100	∅100	10.7	9	1455	DP
•477*	100	∅100	10.7	9	1455	DP
•478*	100	∅100	10.7	9	1455	DP

- Can be equipped with flush valve
- * Hardened cast iron

DP

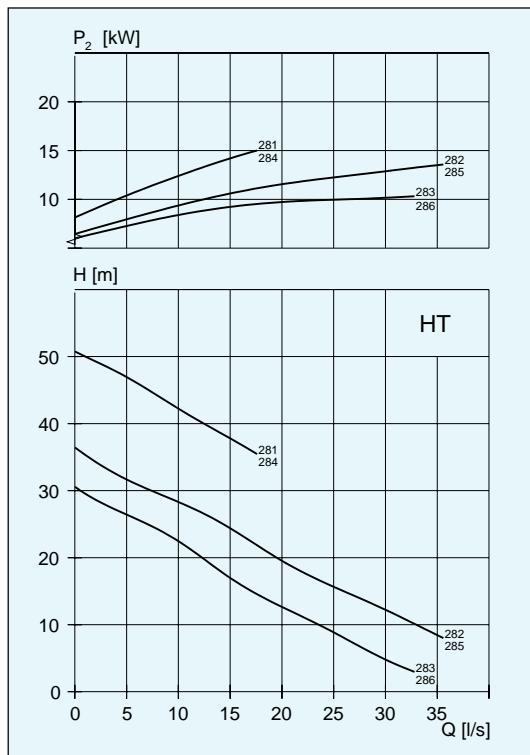

Impeller code	Outlet dia mm DP vers.	Through-let, mm	Motor rating kW		rpm	Available versions
			P ₁	P ₂		
•281	80	∅58	17.0	15.0	2920	DP
•282	80	∅58	17.0	15.0	2920	DP
•283	80	∅58	17.0	15.0	2920	DP
•284	80	∅58	17.0	15.0	2920	DP
•285	80	∅58	17.0	15.0	2920	DP
•286	80	∅58	17.0	15.0	2920	DP

- Can be equipped with flush valve
- * Hardened cast iron

F-PUMPS • 50 Hz

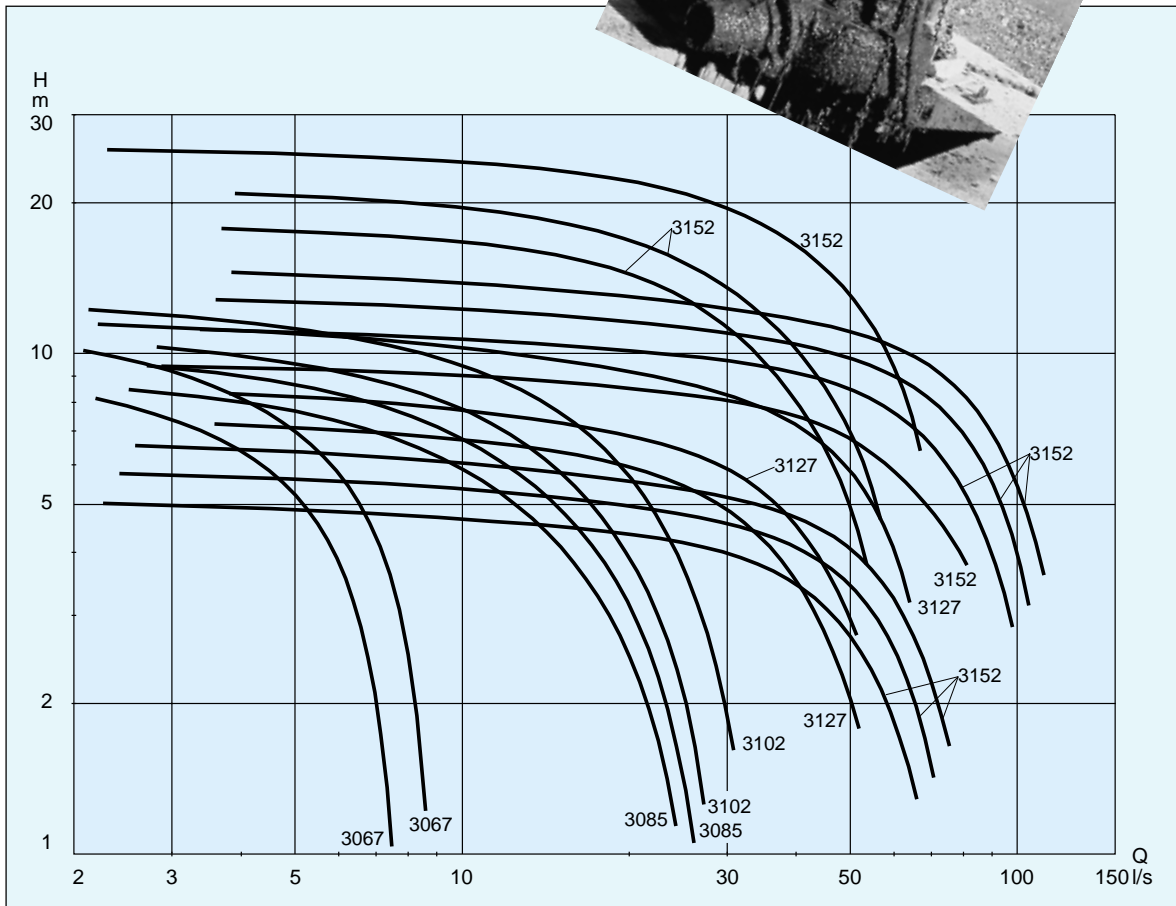
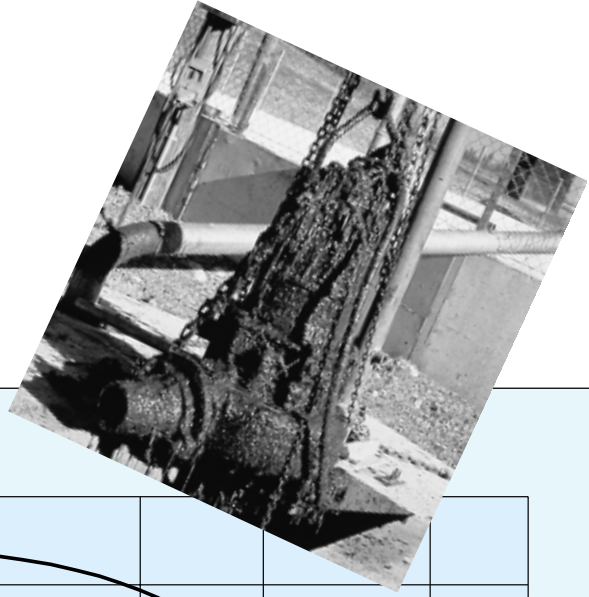

F-pumps have an open impeller in a volute. The impeller is S-shaped and is fitted with a cutter, to enable it to chop up straw and other long-fibrous material. This prevents clogging.



The inlet part of the impeller is screw shaped, which enables the feeding of manure when it is thickest and most difficult to move, into the pump. The cutting plate together with the impeller chop up long-fibrous material before it enters into the pump.

F 3067

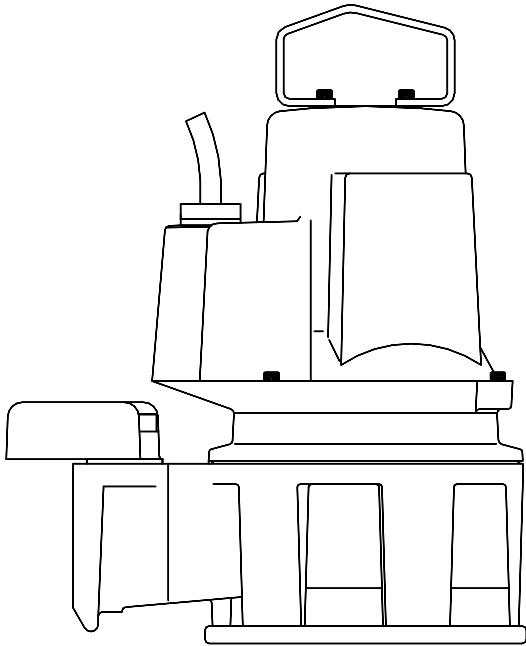

Pump type	FP	FS
Weight, kg	38	38

FP/FS

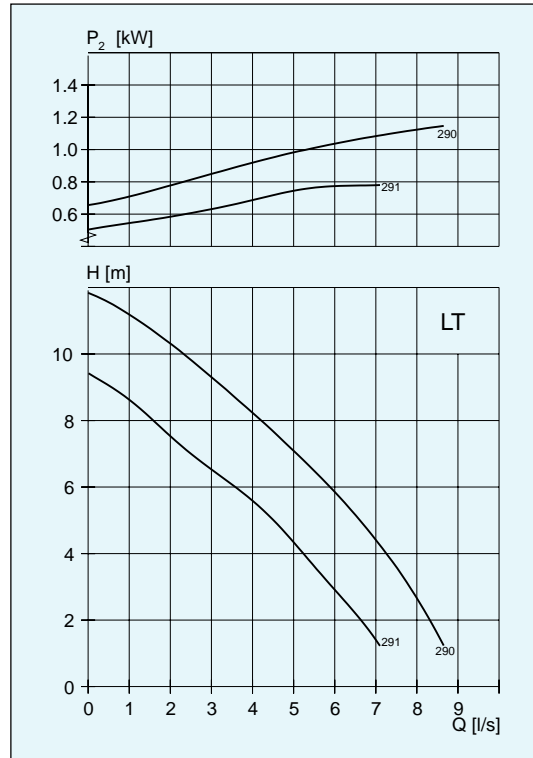

Impeller code	No. of vanes	Outlet dia mm FP vers.	Motor rating kW		rpm	Available versions
			P ₁	P ₂		
W290	3	50	1.6	1.2	2820	FP/FS
W291	3	50	1.6	1.2	2820	FP/FS
291*	3	50	1.5	1.0	2845	FP/FS

* Single-phase

F 3085

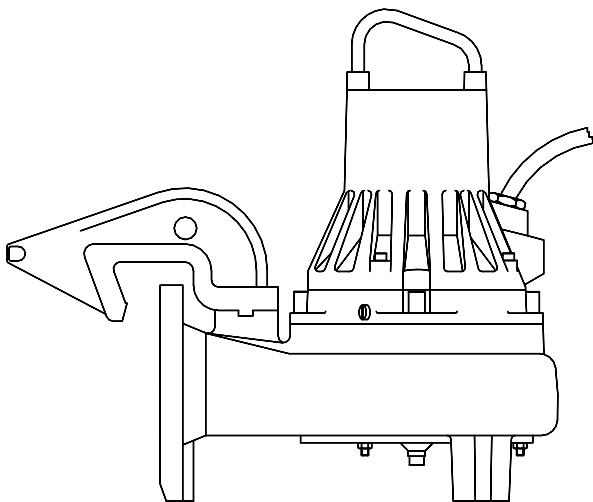

Pump type	FP	FS
Weight, kg	85	84

FP/FS

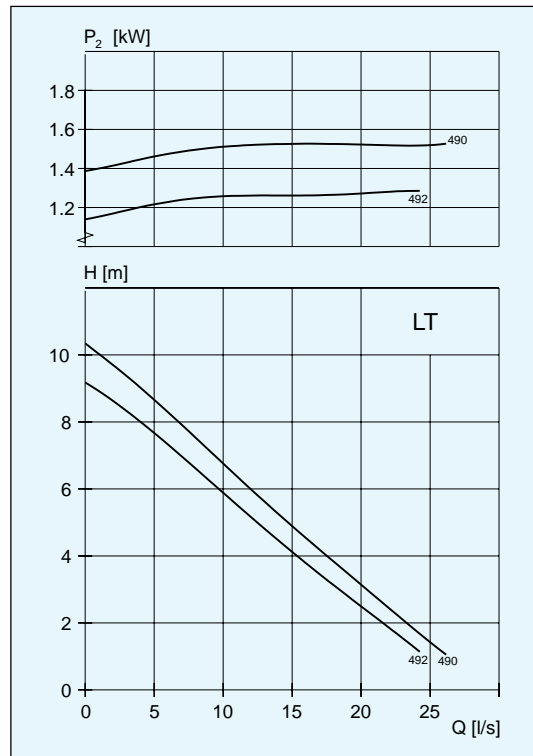

Impeller code	No. of vanes	Outlet dia mm FP vers.	Motor rating kW		rpm	Available versions
			P ₁	P ₂		
W490	2	100	2.7	2.0	1395	FP/FS
W492	2	100	2.7	2.0	1395	FP/FS
492*	2	100	2.0	1.5	1440	FP/FS

* Single-phase

F 3102

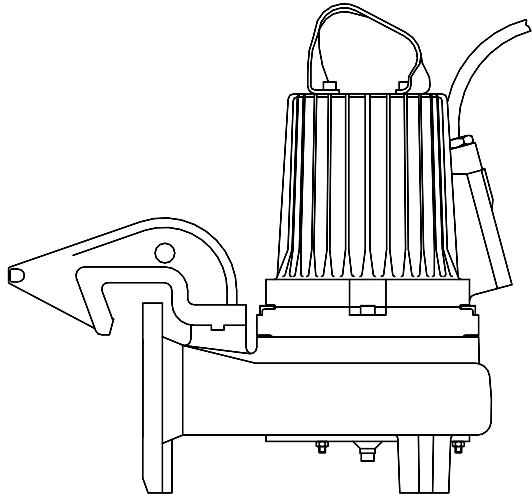

Pump type	FP	FS
Weight, kg	107	105

FP/FS

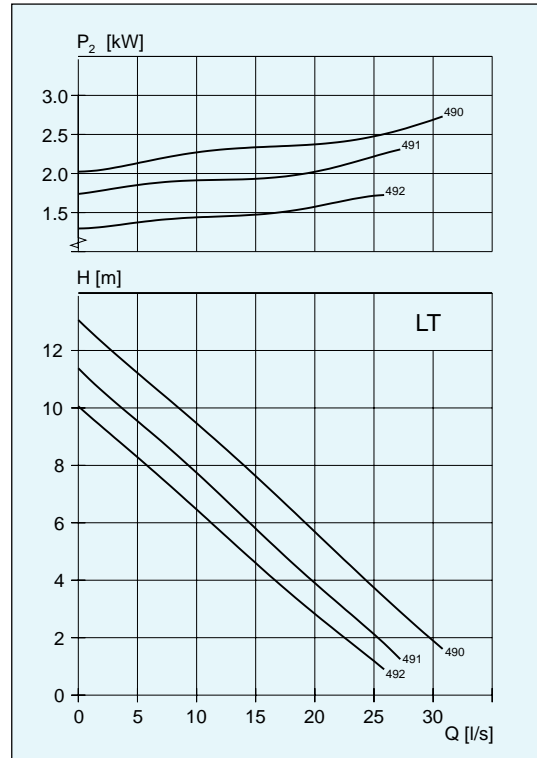

Impeller code	No. of vanes	Outlet dia mm FP vers.	Motor rating kW		rpm	Available versions
			P ₁	P ₂		
W490	2	100	3.8	3.1	1440	FP/FS
W491	2	100	3.8	3.1	1440	FP/FS
W492	2	100	3.8	3.1	1440	FP/FS

F 3127

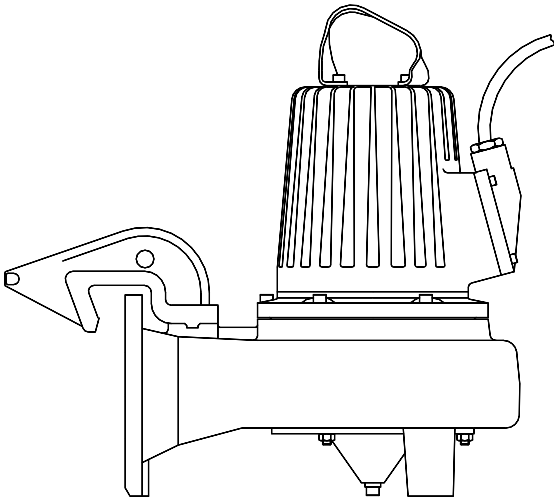

Pump type	FP	FS	FJ
Weight, kg	154	157	162

FP/FS/FJ

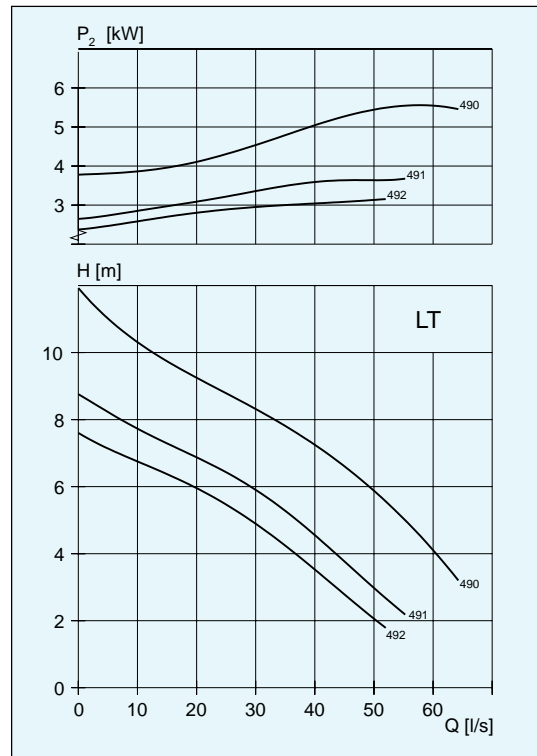

Impeller code	No. of vanes	Outlet dia mm FP vers.	Motor rating kW		rpm	Available versions
			P ₁	P ₂		
W490	2	150	7.0	5.9	1445	FP/FS/FJ
490	2	150	5.7	4.7	1445	FP/FS/FJ
W491	2	150	7.0	5.9	1445	FP/FS/FJ
491	2	150	5.7	4.7	1445	FP/FS/FJ
W492	2	150	7.0	5.9	1445	FP/FS/FJ
492	2	150	5.7	4.7	1445	FP/FS/FJ

F 3152

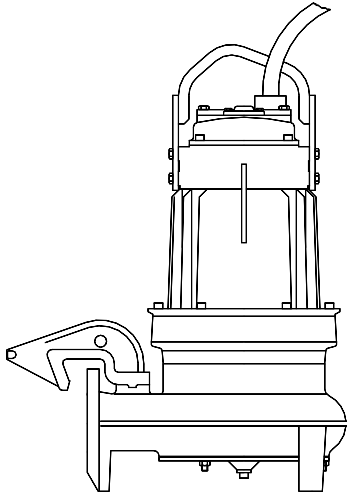

Pump type	FP	FS	FJ
Weight, kg	235	234	241

FP/FS/FJ

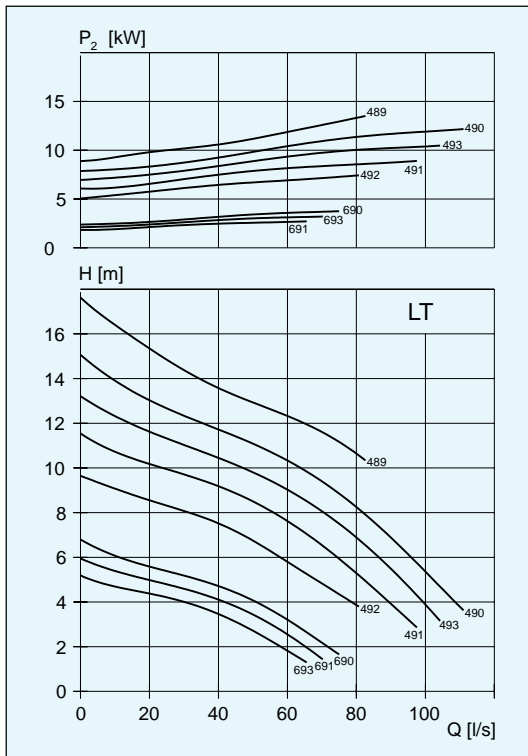

Impeller code	No. of vanes	Outlet dia mm FP vers.	Motor rating kW		rpm	Available versions
			P ₁	P ₂		
489	2	150	15.8	13.5	1450	FP/FS/FJ
490	2	150	15.8	13.5	1450	FP/FS/FJ
491	2	150	15.8	13.5	1450	FP/FS/FJ
491	2	150	10.7	9.0	1450	FP/FS/FJ
492	2	150	10.7	9.0	1450	FP/FS/FJ
492	2	150	8.9	7.5	1450	FP/FS/FJ
493	2	150	15.8	13.5	1450	FP/FS/FJ
493	2	150	10.5	8.8	900	FP/FS/FJ
690	2	150	10.5	8.8	900	FP/FS/FJ
691	2	150	10.5	8.8	900	FP/FS/FJ
693	2	150	10.5	8.8	900	FP/FS/FJ

FP/FS/FJ

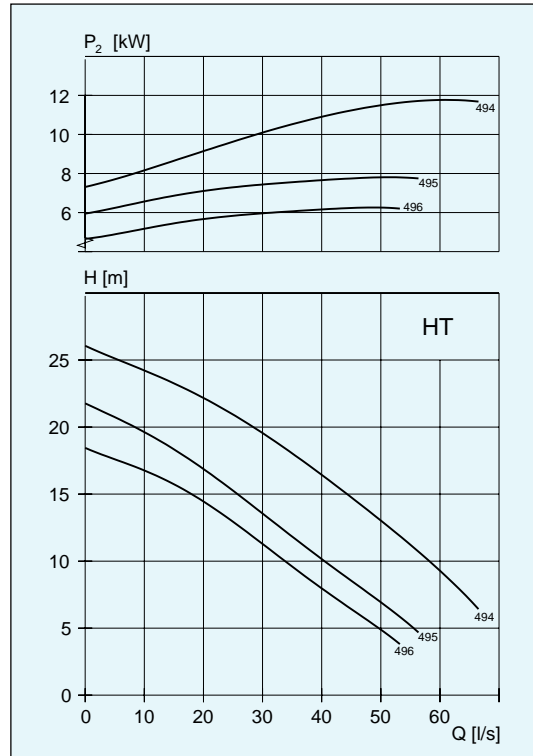

Impeller code	No. of vanes	Outlet dia mm FP vers.	Motor rating kW		rpm	Available versions
			P ₁	P ₂		
494	2	100	15.8	13.5	1450	FP/FS/FJ
495	2	100	15.8	13.5	1450	FP/FS/FJ
495	2	100	10.7	9.0	1450	FP/FS/FJ
496	2	100	15.8	13.5	1450	FP/FS/FJ
496	2	100	10.7	9.0	1450	FP/FS/FJ
496	2	100	8.9	7.5	1450	FP/FS/FJ

H-PUMPS • 50 Hz

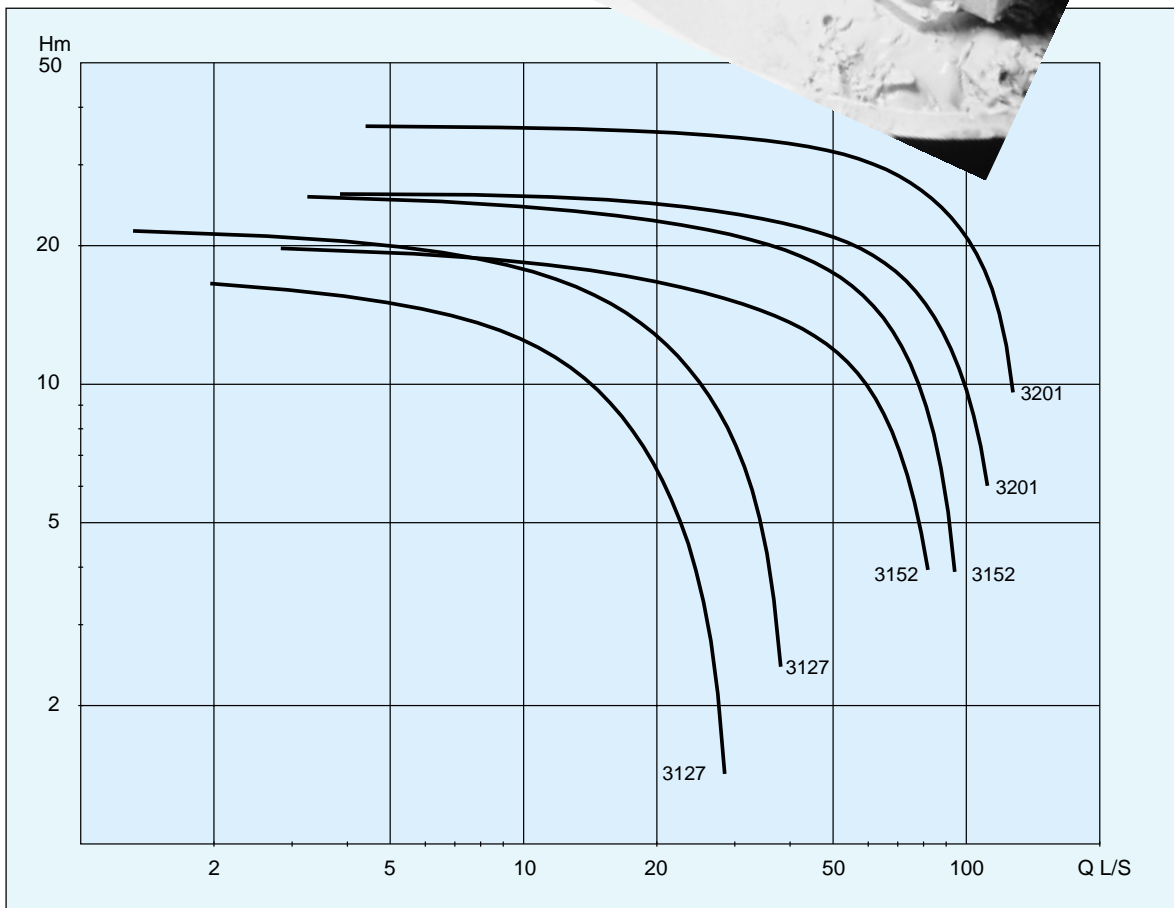
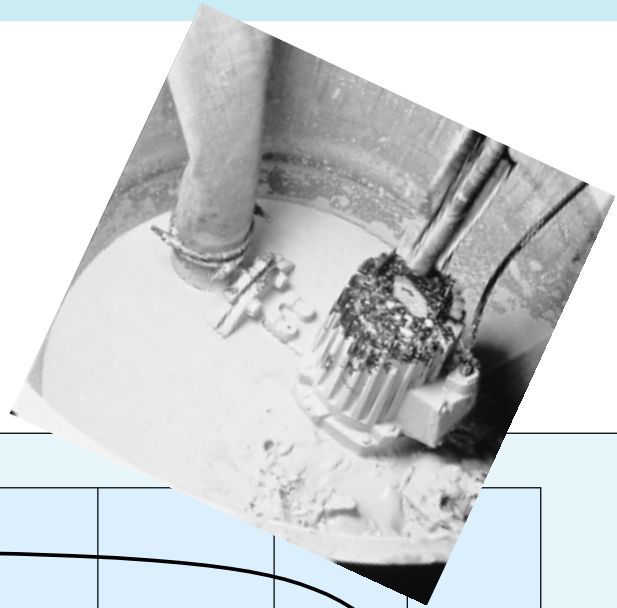

The H-pump's impeller is an open or shrouded channel impeller, made of a highly wear resistant cast material. The pump-housing incorporate adjustable and replaceable rubberlined wear parts.

H 3127

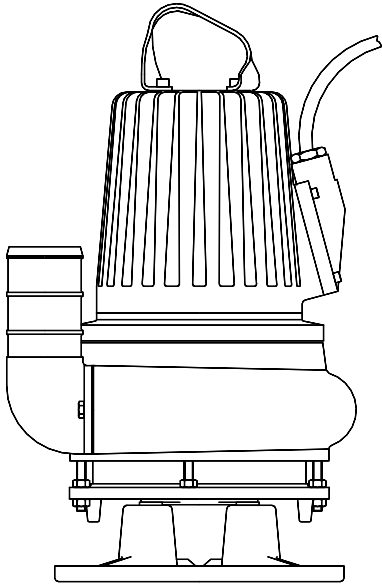

Weight, kg	HS
HT	157

HS

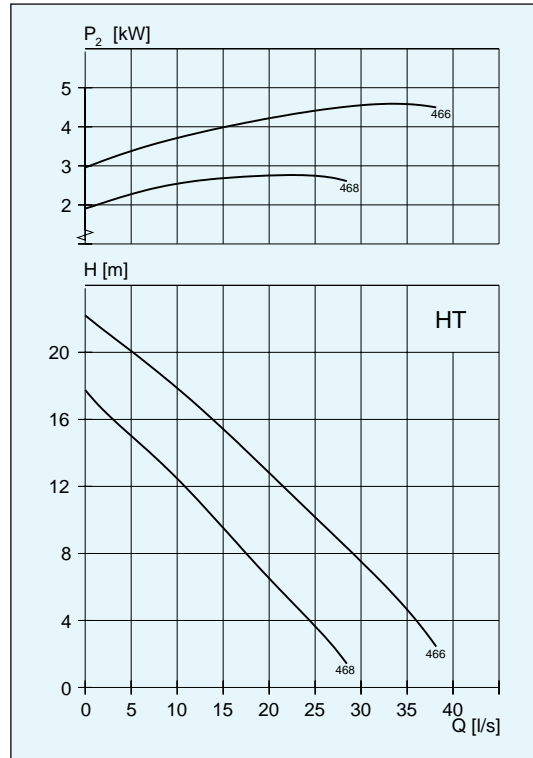

Impeller code	No. of channels	Outlet dia mm	Through-let, mm	Rated power kW		rpm	Available versions
				P_1	P_2		
W466	1	∅ 80	51	7.0	5.9	1445	HS
466	1	∅ 80	51	5.7	4.7	1445	HS
W468	1	∅ 80	50	7.0	5.9	1445	HS
468	1	∅ 80	50	5.7	4.7	1445	HS

H 3152

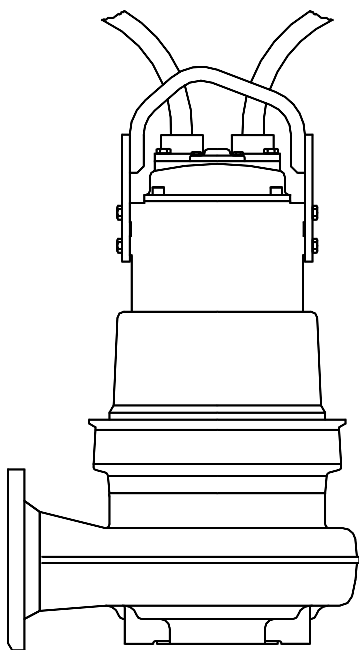

Weight, kg	HP	HS
HT	263	274

HP/HS

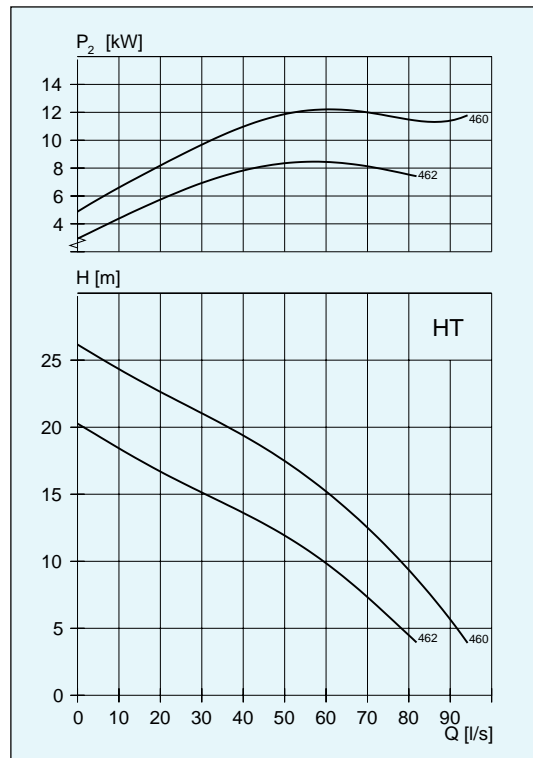

Impeller code	No. of channels	Outlet dia mm	Through-let, mm	Rated power kW		rpm	Available versions
				P_1	P_2		
460*	3	∅ 150	50	15.8	13.5	1450	HS
W462*	3	∅ 150	50	15.8	13.5	1450	HS
462*	3	∅ 150	50	10.7	9	1455	HS

* $NPSH_{10} = 11 \text{ m at } 84 \text{ l/s}$

H 3201

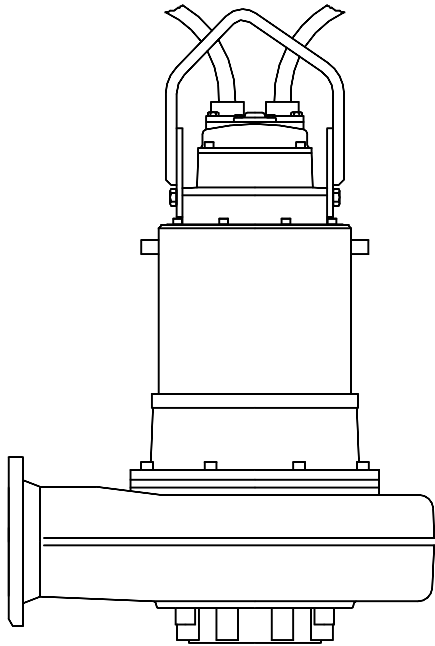

Weight, kg	HS
HT	497

HS

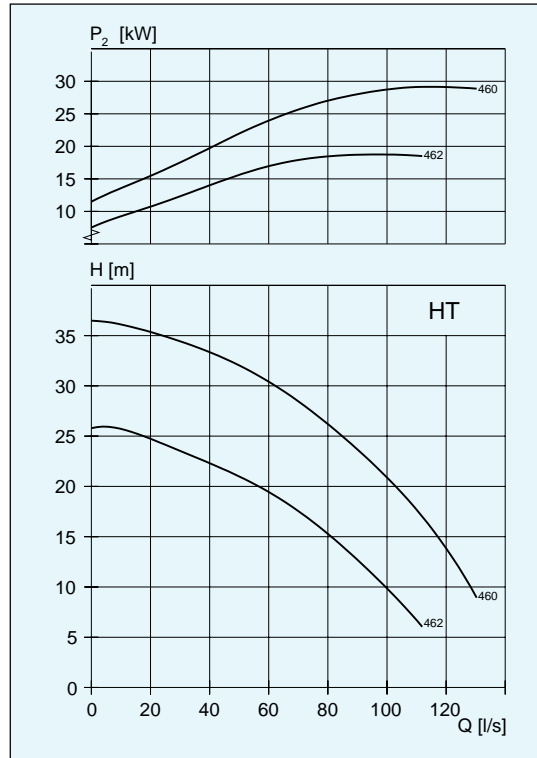

Impeller code	No. of channels	Outlet dia mm	Through-let, mm	Rated power kW		rpm	Available versions
				P ₁	P ₂		
460	3	∅ 150	59 x 62	25	30	1455	HS
W462	3	∅ 150	59 x 65	25	30	1455	HS
462	3	∅ 150	59 x 65	34	22	1460	HS

H-PUMPS • 50 Hz

HIGH CHROME AND POLYURETHANE

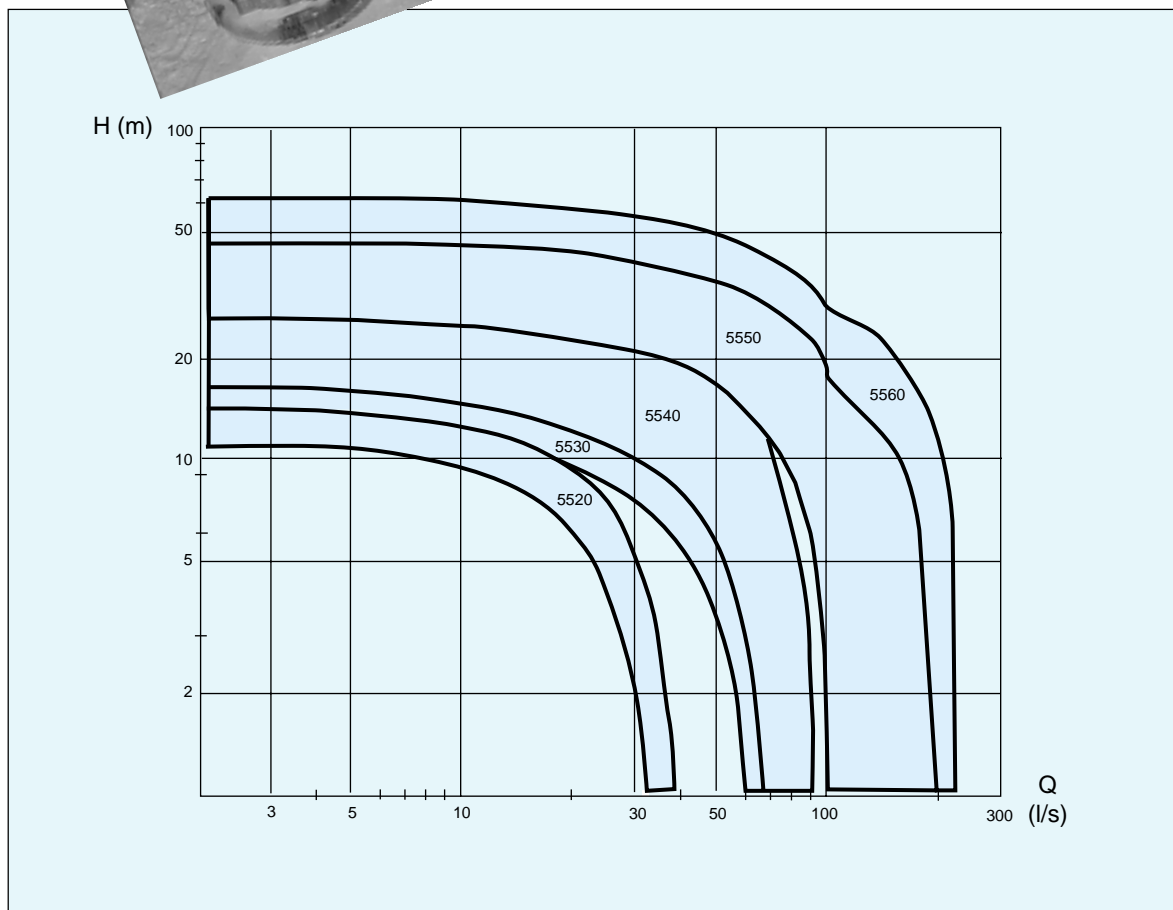
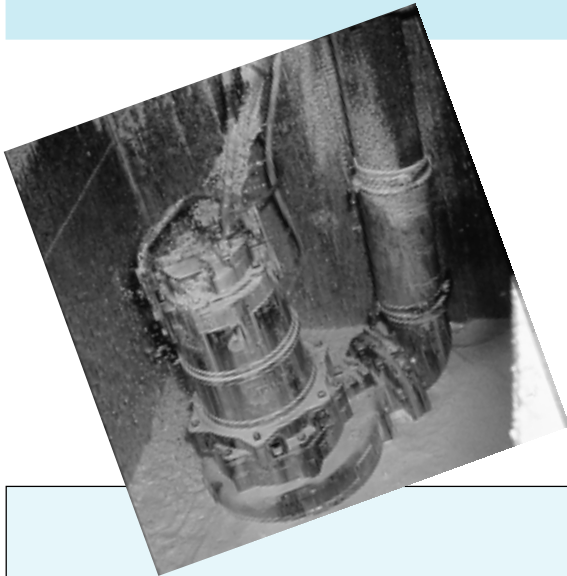

Heavy duty three channel impeller
manufactured from high chrome or
polyurethane.



H 5100

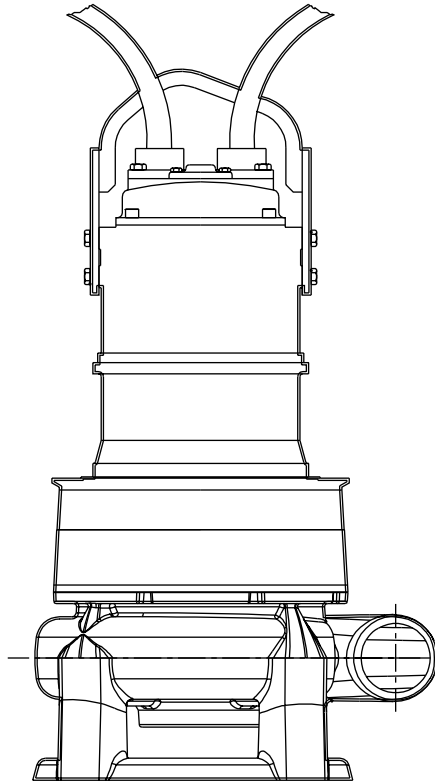

Pump type	HS
Weight, kg HC	260

HC = High chrome

HS

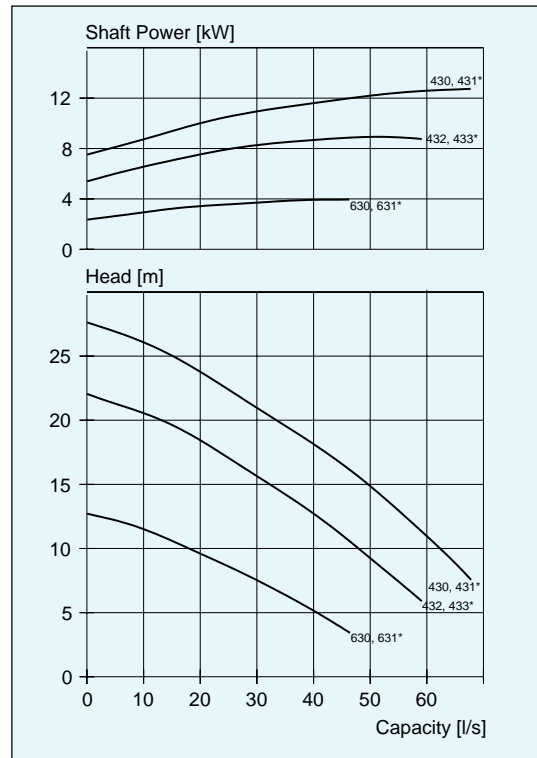

Impeller code	No. of channels	Outlet dia mm	Through-let, mm	Rated power kW		rpm	Available versions
				P ₁	P ₂		
630 HC	3	∅100	40	10.5	8.8	970	HS
631 HC*	3	∅100	40	10.5	8.8	970	HS
430 HC	3	∅100	40	15.7	13.5	1450	HS
431 HC*	3	∅100	40	15.7	13.5	1450	HS
432 HC	3	∅100	40	15.7	13.5	1450	HS
433 HC*	3	∅100	40	15.7	13.5	1450	HS

* With agitator

H 5520

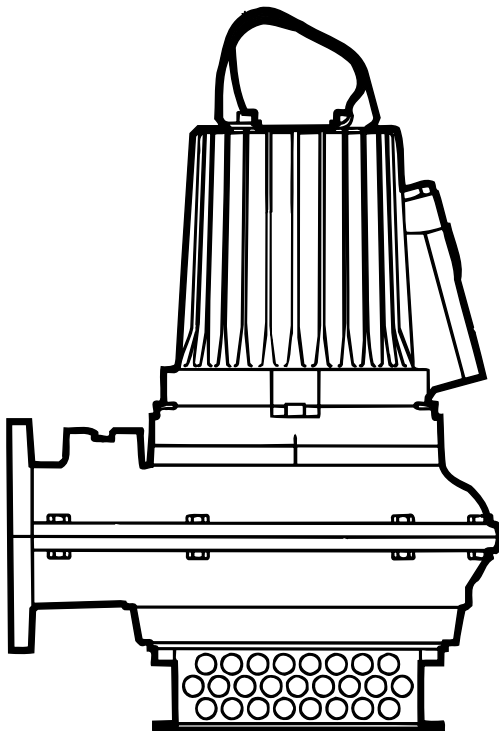

Pump type	HP	HS	HT	HZ
Weight, kg HC	122	171	161	122

HC = High chrome

HP/HS/HT/HZ

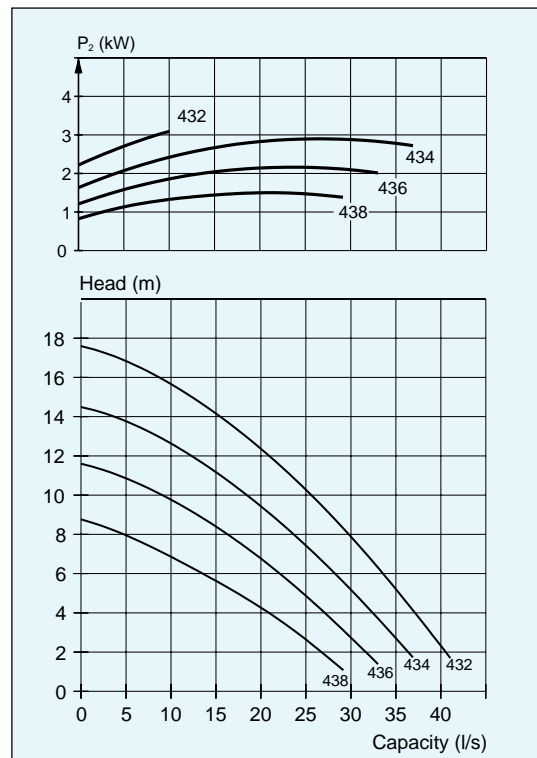

Impeller code	No. of channels	Outlet dia mm	Through-let, mm	Rated power kW		rpm	Available versions
				P ₁	P ₂		
432 HC	3	∅100	30	3.8	3.1	1440	HP/HS/HT/HZ
434 HC	3	∅100	30	3.8	3.1	1440	HP/HS/HT/HZ
436 HC	3	∅100	30	3.8	3.1	1440	HP/HS/HT/HZ
438 HC	3	∅100	30	3.8	3.1	1440	HP/HS/HT/HZ

H 5530

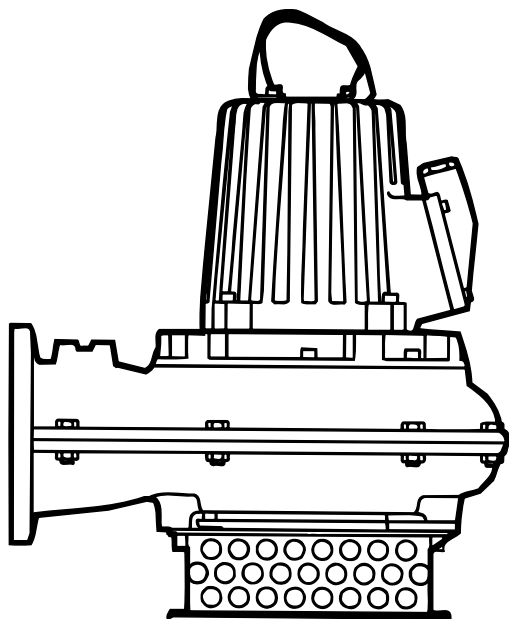

Pump type	HP	HS
Weight, kg HC	203	309

HP/HS

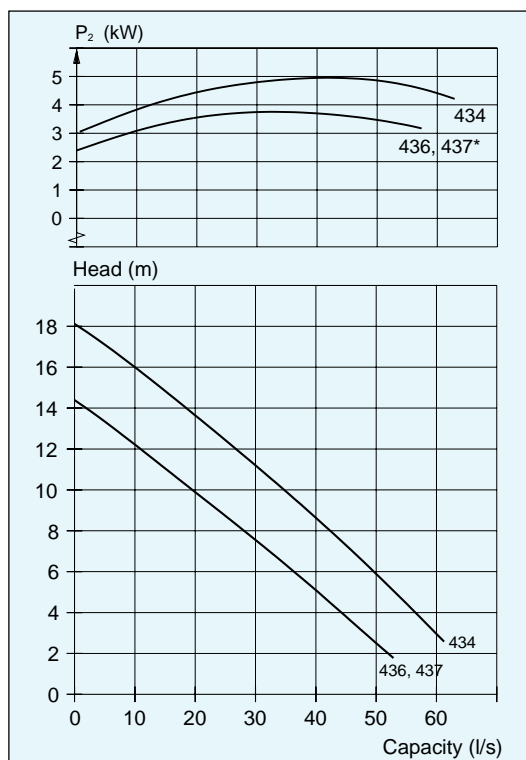

Impeller code	No. of channels	Outlet dia mm	Through-let, mm	Rated power kW		rpm	Available versions
				P ₁	P ₂		
434HC	3	∅ 150	40	7.0	5.9	1450	HPHS
436HC	3	∅ 150	40	7.0	5.9	1450	HPHS
437HC*	3	∅ 150	40	7.0	5.9	1450	HPHS

*with agitator

H 5540

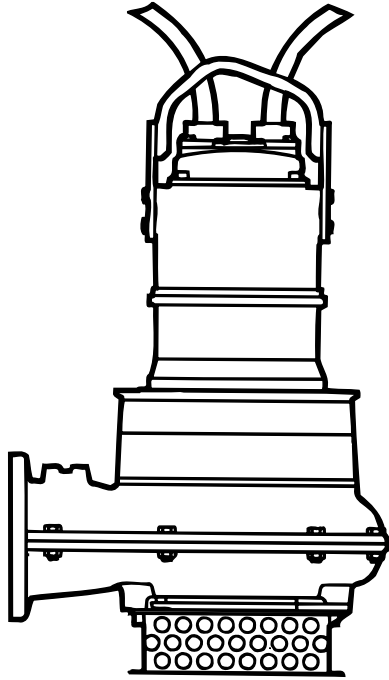

Pump type	HP	HS	HT	HZ
Weight, kg HC	298	404	384	298

HP/HS/HT/HZ

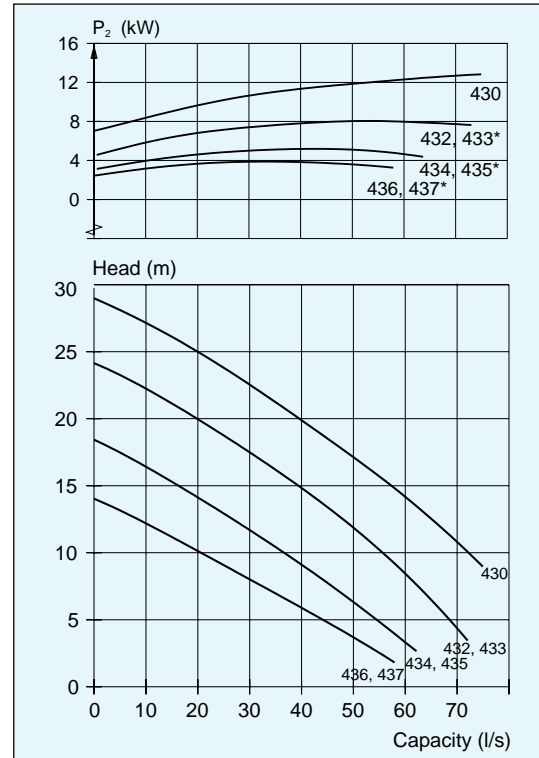

Impeller code	No. of channels	Outlet dia mm	Through-let, mm	Rated power kW		rpm	Available versions
				P ₁	P ₂		
430 HC	3	∅ 150	40	15.7	13.5	1450	HP/HS/HT/HZ
432 HC	3	∅ 150	40	15.7	13.5	1450	HP/HS/HT/HZ
433 HC*	3	∅ 150	40	15.7	13.5	1450	HP/HS/HT/HZ
434 HC	3	∅ 150	40	15.7	13.5	1450	HP/HS/HT/HZ
435 HC*	3	∅ 150	40	15.7	13.5	1450	HP/HS/HT/HZ
436 HC	3	∅ 150	40	15.7	13.5	1450	HP/HS/HT/HZ
437 HC*	3	∅ 150	40	15.7	13.5	1450	HP/HS/HT/HZ

* with agitator

H 5550

HP/HS/HT/HZ

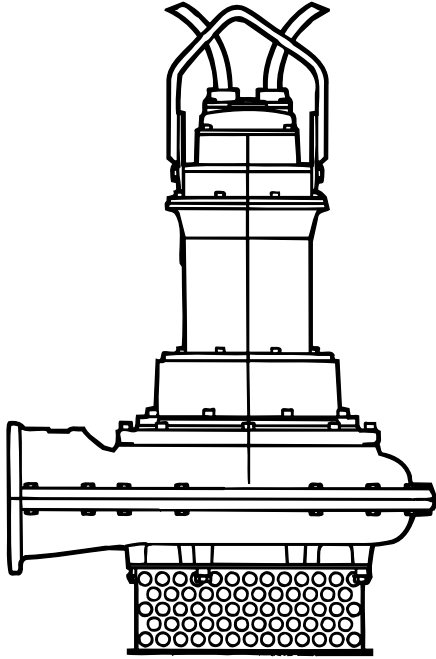

Pump type	HP	HS	HT	HZ
Weight, kg HC	640	836	796	640

* With agitator, extra powerdraw;
 0.7 kW (451)
 4.0 kW (453, 455, 457, 459)
 0.4 kW (5560-631, 5550-635)
 1.1 kW (5560-633, -635, -637, -639, -643, -645, -647, -649, 5550-637, -639)

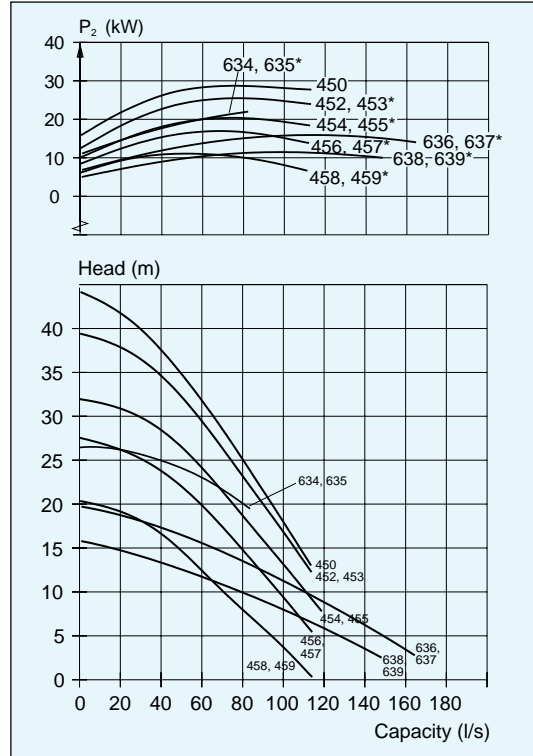

Impeller code	No. of channels	Outlet dia mm	Through-let, mm	Rated power kW		rpm	Available versions
				P ₁	P ₂		
634 HC	3	∅ 200	60	25	22	966	HPHSHT/HZ
635 HC*	3	∅ 200	60	25	22	966	HPHSHT/HZ
636 HC	3	∅ 200	60	25	22	966	HPHSHT/HZ
637 HC*	3	∅ 200	60	25	22	966	HPHSHT/HZ
638 HC	3	∅ 200	60	25	22	966	HPHSHT/HZ
639 HC*	3	∅ 200	60	25	22	966	HPHSHT/HZ
450 HC	3	∅ 200	40	34	30	1455	HPHSHT/HZ
452 HC	3	∅ 200	40	34	30	1455	HPHSHT/HZ
453 HC*	3	∅ 200	40	34	30	1455	HPHSHT/HZ
454 HC	3	∅ 200	40	34	30	1455	HPHSHT/HZ
455 HC*	3	∅ 200	40	34	30	1455	HPHSHT/HZ
456 HC	3	∅ 200	40	34	30	1455	HPHSHT/HZ
457 HC*	3	∅ 200	40	34	30	1455	HPHSHT/HZ
458 HC	3	∅ 200	40	34	30	1455	HPHSHT/HZ
459 HC*	3	∅ 200	40	34	30	1455	HPHSHT/HZ

H 5560

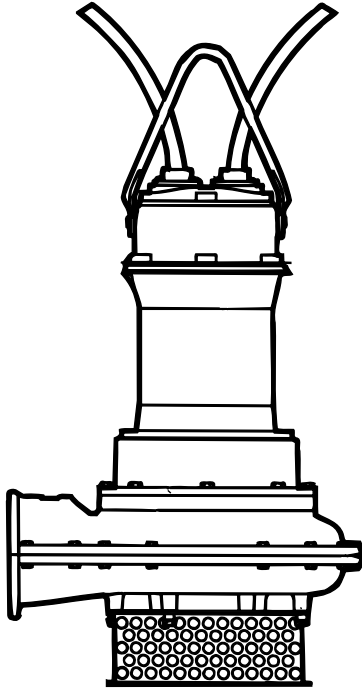

Pump type	HP	HS	HT	HZ
Weight, kg HC	962	1158	1118	962

* With agitator, extra powerdraw;
 0.7 kW (451)
 4.0 kW (453, 455, 457, 459)
 0.4 kW (5560-631, 5550-635)
 1.1 kW (5560-633, -635, -637, -639, -643, -645, -647, -649, 5550-637, -639)

HP/HS/HT/HZ

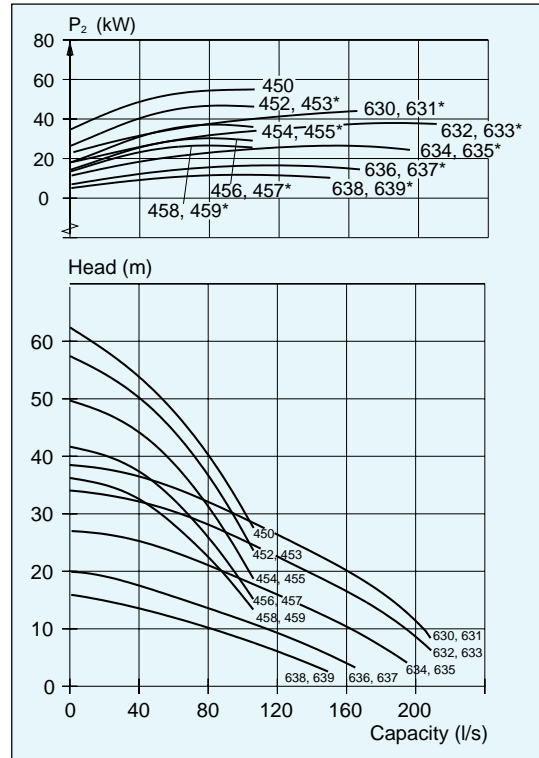

Impeller code	No. of channels	Outlet dia mm	Through-let, mm	Rated power kW		rpm	Available versions
				P ₁	P ₂		
630 HC	3	∅200	60	50	44	970	HP/HS/HT/HZ
631 HC*	3	∅200	60	50	44	970	HP/HS/HT/HZ
632 HC	3	∅200	60	50	44	970	HP/HS/HT/HZ
633 HC*	3	∅200	60	50	44	970	HP/HS/HT/HZ
634 HC	3	∅200	60	50	44	970	HP/HS/HT/HZ
635 HC*	3	∅200	60	50	44	970	HP/HS/HT/HZ
636 HC	3	∅200	60	50	44	970	HP/HS/HT/HZ
637 HC*	3	∅200	60	50	44	970	HP/HS/HT/HZ
638 HC	3	∅200	60	50	44	970	HP/HS/HT/HZ
639 HC*	3	∅200	60	50	44	970	HP/HS/HT/HZ
450 HC	3	∅200	40	60	54	1470	HP/HS/HT/HZ
452 HC	3	∅200	40	60	54	1470	HP/HS/HT/HZ
453 HC*	3	∅200	40	60	54	1470	HP/HS/HT/HZ
454 HC	3	∅200	40	60	54	1470	HP/HS/HT/HZ
455 HC*	3	∅200	40	60	54	1470	HP/HS/HT/HZ
456 HC	3	∅200	40	60	54	1470	HP/HS/HT/HZ
457 HC*	3	∅200	40	60	54	1470	HP/HS/HT/HZ
458 HC	3	∅200	40	60	54	1470	HP/HS/HT/HZ
459 HC*	3	∅200	40	60	54	1470	HP/HS/HT/HZ

L-PUMPS • 50 Hz

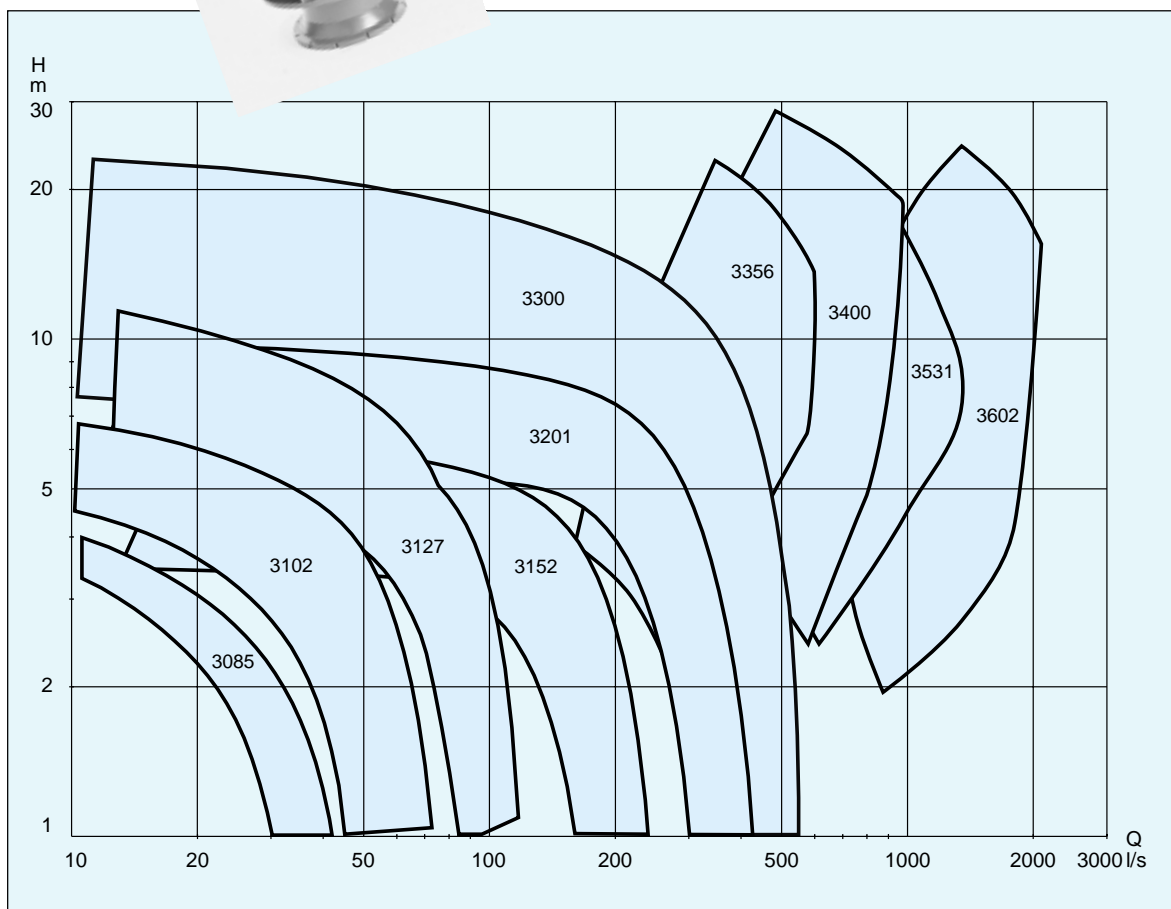

The L-pump's impeller is a shrouded channel impeller in a volute with guide vanes. The guide-vane section leads the rotating water outward and upward on the outside of the pump. L-pumps are mainly used in sewage-treatment plants and in such applications as storm-water pumping, irrigation and drainage.



L 3085

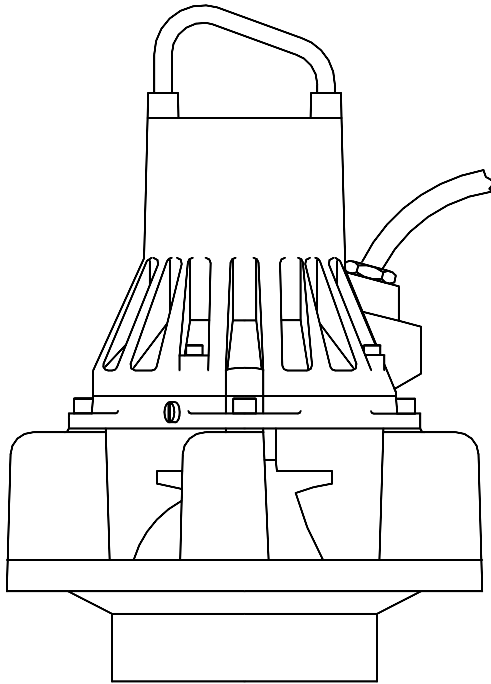

Pump type	L
Weight, kg	75

L

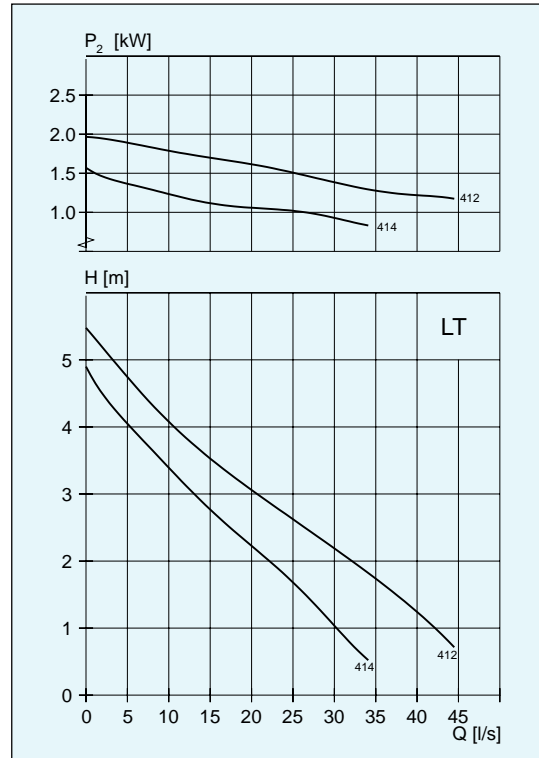

Impeller code	Overall dia mm diffuser ring	Motor rating, kW		rpm
		P_1	P_2	
W412	∅ 380	2.7	2.0	1385
W414	∅ 380	2.7	2.0	1395

L 3102

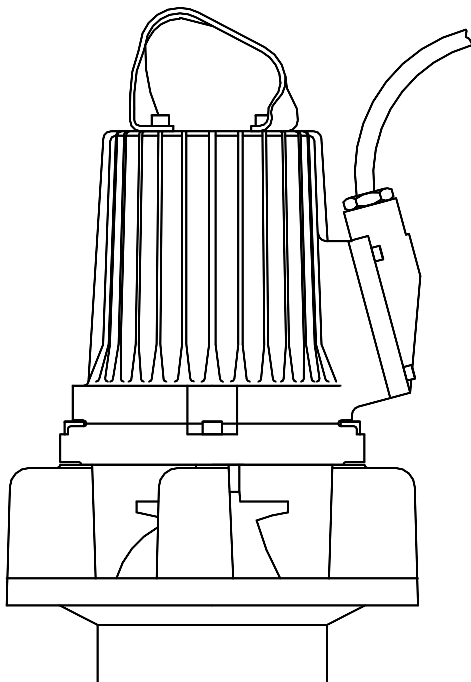

Pump type	L
Weight, kg	95

L

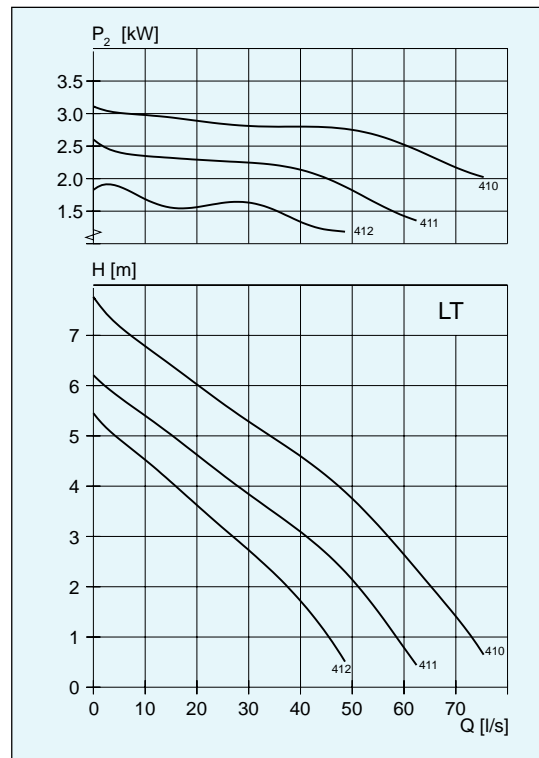

Impeller code	Overall dia mm diffuser ring	Motor rating, kW		rpm
		P_1	P_2	
W410	∅ 380	3.8	3.1	1435
W411	∅ 380	3.8	3.1	1435
W412	∅ 380	3.8	3.1	1435

NL 3102

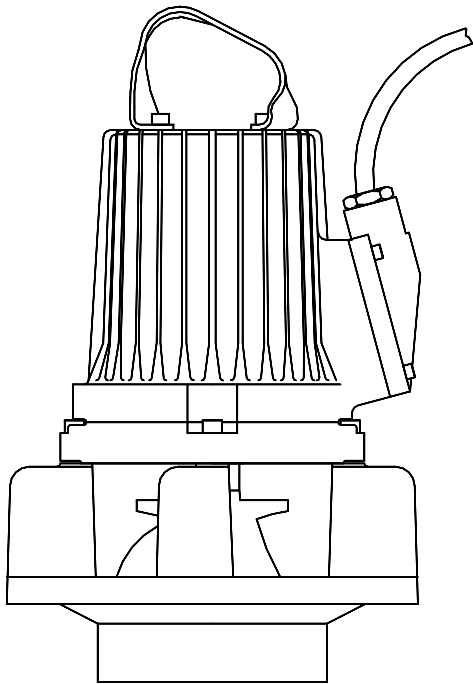

Pump type	NL
Weight, kg	99

NL

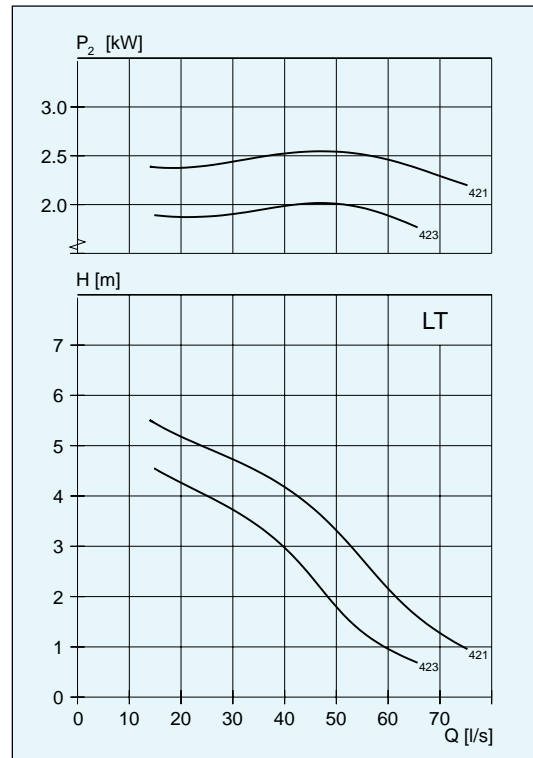

Impeller code	Overall dia mm diffuser ring	Motor rating, kW		rpm
		P ₁	P ₂	
W421	∅380	3.8	3.1	1435
W423	∅380	3.8	3.1	1435

L 3127

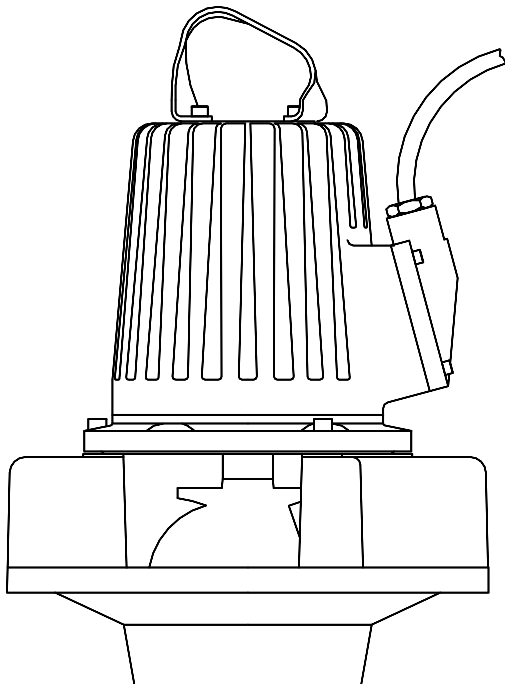

Pump type	L
Weight, kg	133

L

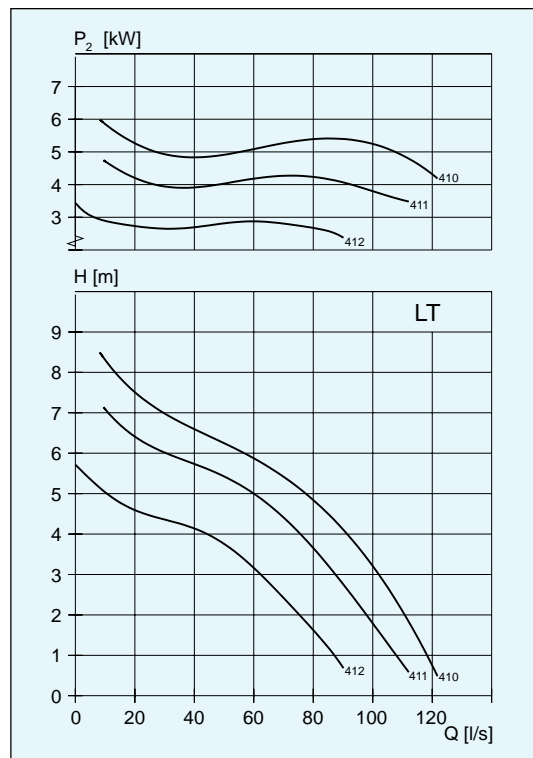

Impeller code	Overall dia mm diffuser ring	Motor rating, kW		rpm
		P ₁	P ₂	
W410	∅480	7.1	5.9	1445
W411	∅480	7.1	5.9	1445
411	∅480	5.7	4.7	1445
W412	∅480	7.1	5.9	1445
412	∅480	5.7	4.7	1445

NL 3127

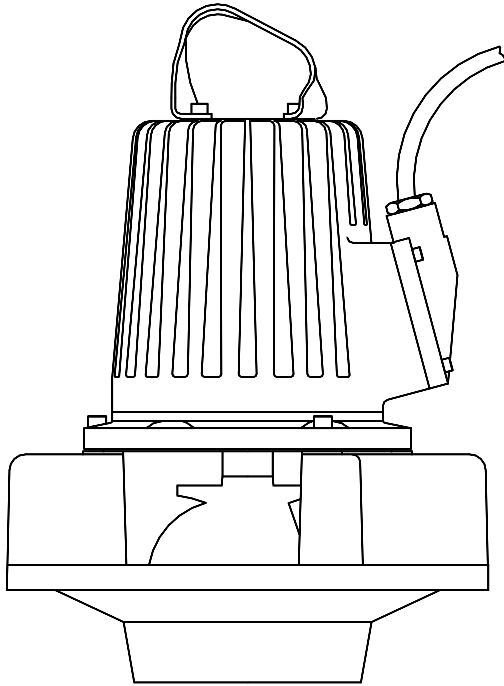

Pump type	NL
Weight, kg	140

NL

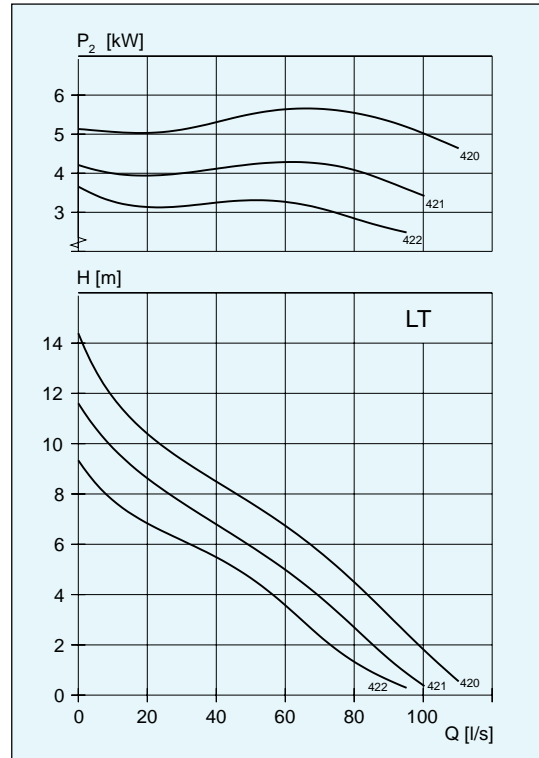

Impeller code	Overall dia mm diffuser ring	Motor rating, kW		rpm
		P ₁	P ₂	
W420	∅480	7.1	5.9	1445
W421	∅480	7.1	5.9	1445
421	∅480	5.7	4.7	1445
W422	∅480	7.1	5.9	1445
422	∅480	5.7	4.7	1445

L 3152

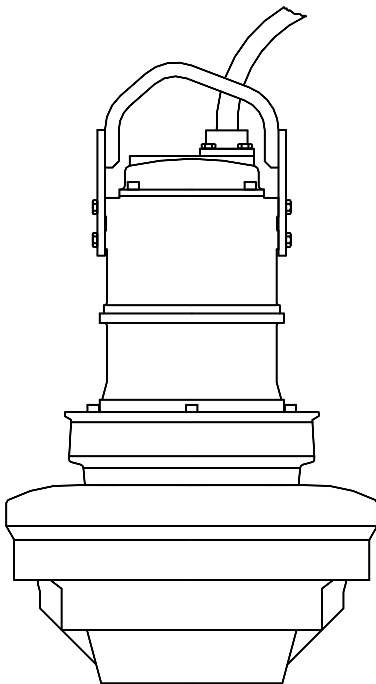

Pump type	L
Weight, kg	264

L

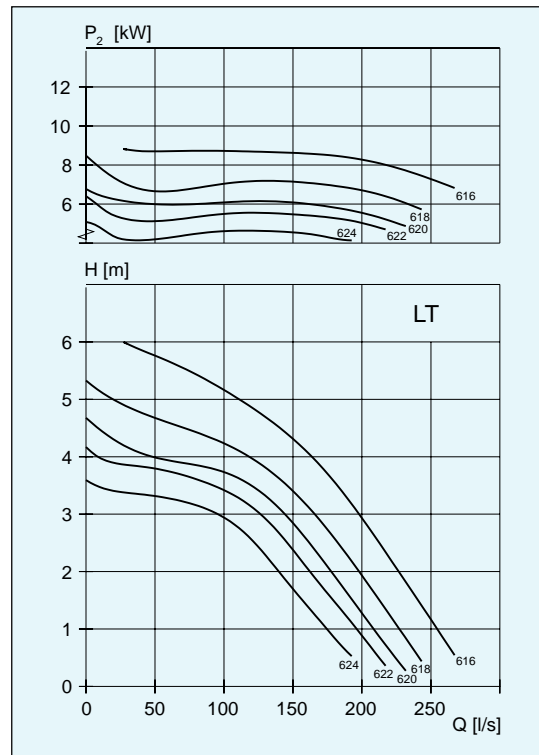

Impeller code	Overall dia mm diffuser ring	Motor rating, kW		rpm
		P ₁	P ₂	
W616*	∅590	10.5	8.8	960
W618*	∅590	10.5	8.8	960
W620	∅590	10.5	8.8	960
W622	∅590	10.5	8.8	960
W624	∅590	10.5	8.8	960

* NPSH_e = 11 m at 235 l/s

L 3201

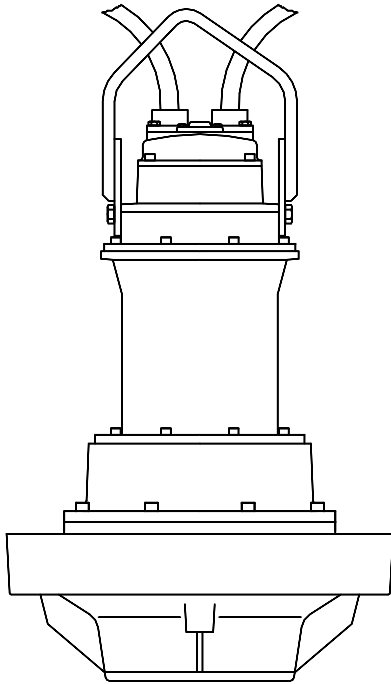

Pump type	L
Weight, kg	450

L

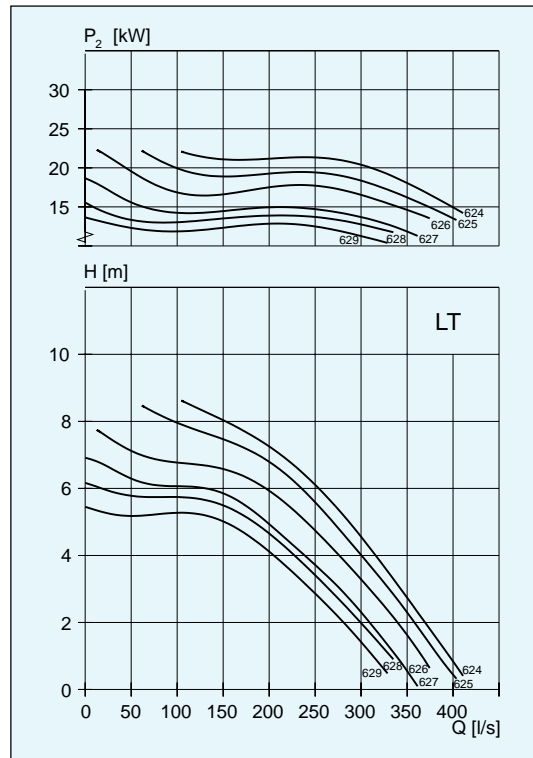

Impeller code	Overall dia mm diffuser ring	Motor rating, kW		rpm
		P ₁	P ₂	
W624	∅ 720	25	22	970
W625	∅ 720	25	22	970
W626	∅ 720	25	22	970
W627	∅ 720	25	22	970
W628	∅ 720	25	22	970
W629	∅ 720	25	22	970

L 3300

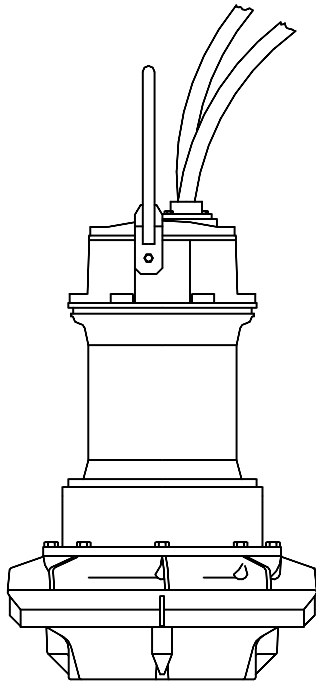

Pump type	L
Weight, kg	750

L

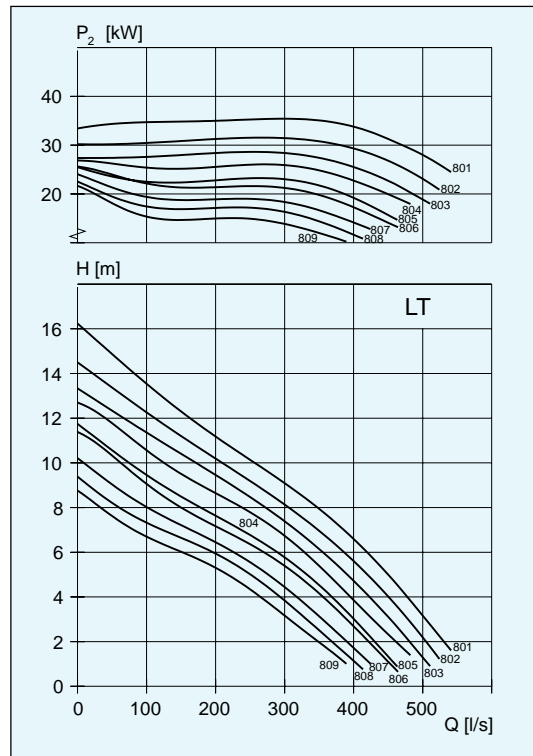

Impeller code	Overall dia mm diffuser ring	Motor rating, kW		rpm
		P ₁	P ₂	
801-809	∅ 780	37	37	730
804-809	∅ 780	31	27	730

NL 3300

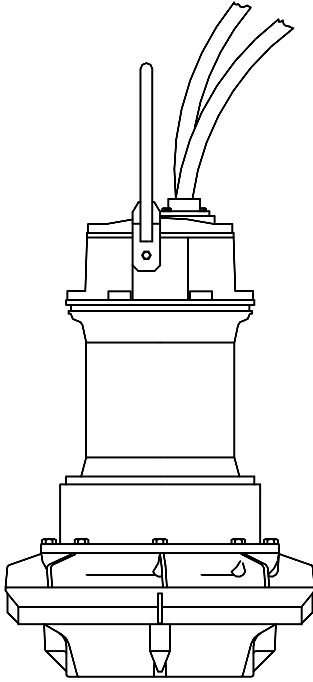

Pump type	NL
Weight, kg	755

NL

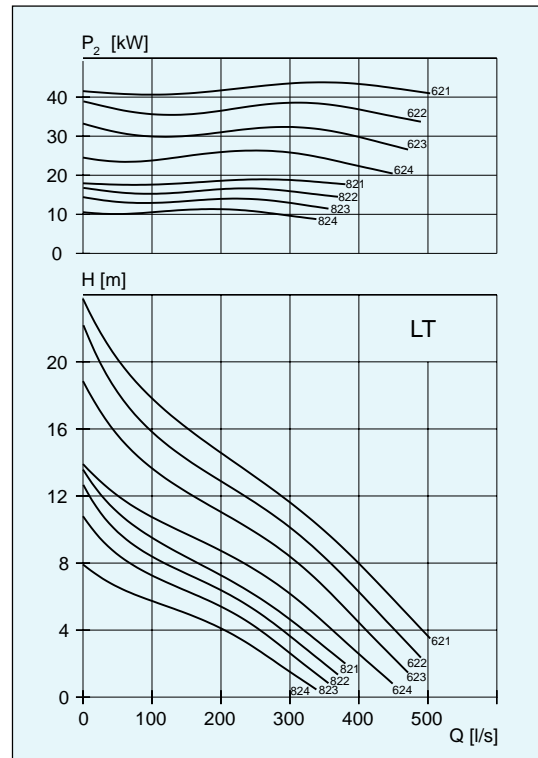

Impeller code	Overall dia mm diffuser ring	Motor rating, kW		rpm
		P ₁	P ₂	
621-624	∅ 800	50	44	975
623-624	∅ 800	39	34	975
821-824	∅ 800	43	37	730
821-824	∅ 800	31	27	730

L 3356

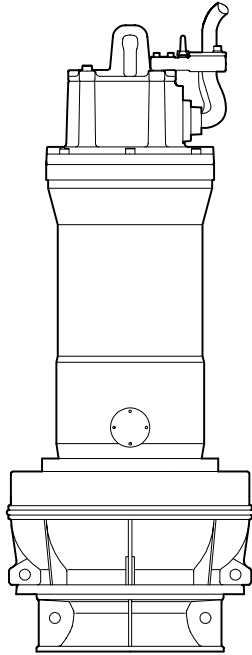

LL

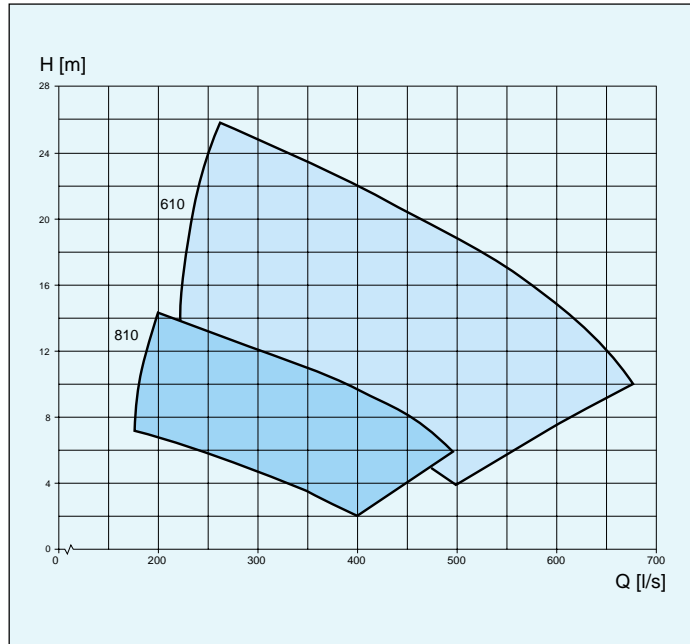

Pump type	L
Weight, kg	1040-1900

Impeller code	Overall dia mm diffuser ring	Motor rating, kW		rpm
		P ₁	P ₂	
610	∅ 785	64-173	58-160	990
810	∅ 785	51-61	45-55	740

L 3400

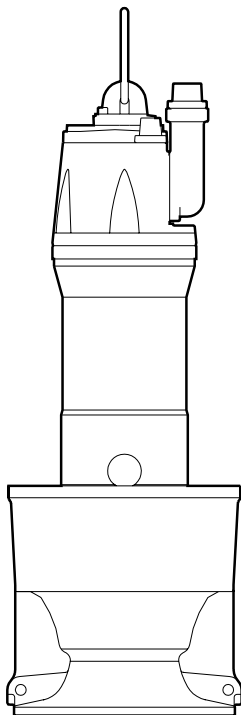

LL

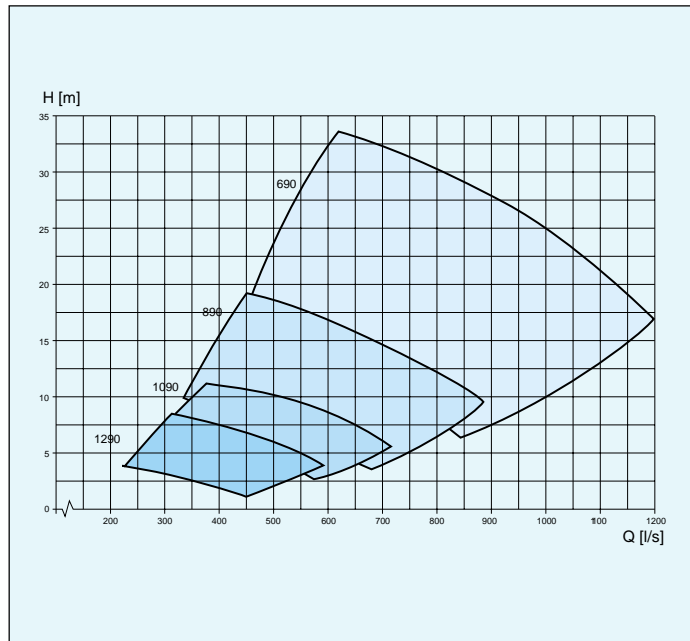

Pump type	L
Weight, kg	1650-3350

Impeller code	Overall dia mm diffuser ring	Motor rating, kW		rpm
		P ₁	P ₂	
690	∅ 860	213-359	200-340	990
890	∅ 860	100-155	90-140	735
1090	∅ 860	44-79	40-70	585
1290	∅ 860	34-51	30-45	490

L 3531

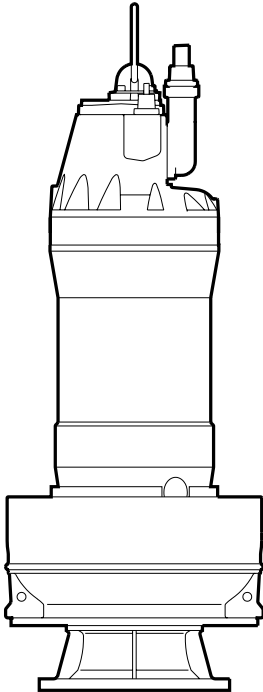

LL

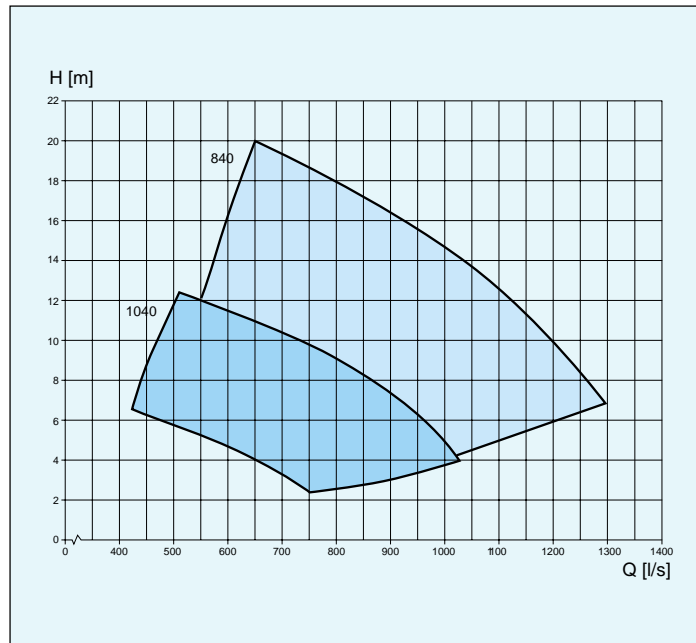

Pump type	L
Weight, kg	2300-4200

Impeller code	Overall dia mm diffuser ring	Motor rating, kW		rpm
		P ₁	P ₂	
840	∅ 1160	111-246	100-230	745
1040	∅ 1160	79-137	70-125	595

L 3602

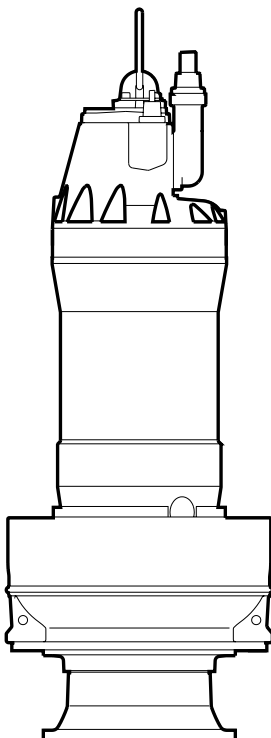

LL

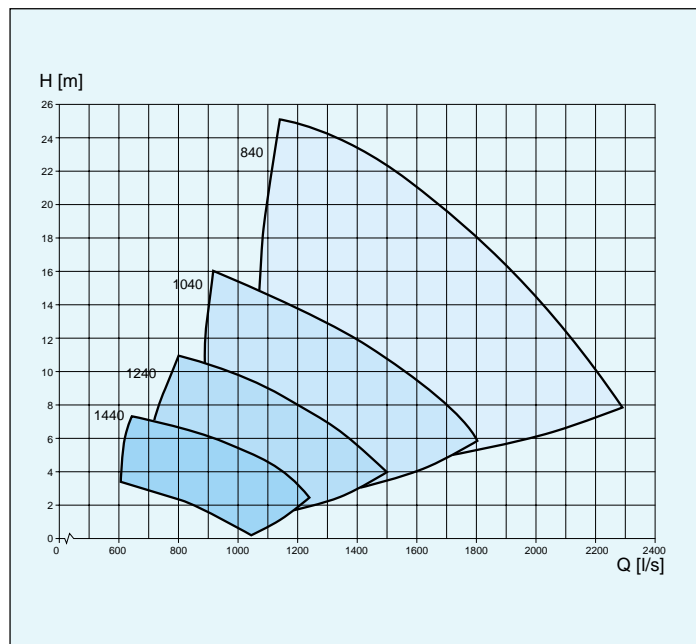

Pump type	L
Weight, kg	2550-4300

Impeller code	Overall dia mm diffuser ring	Motor rating, kW		rpm
		P ₁	P ₂	
840	∅ 1160	246-449	230-430	745
1040	∅ 1160	111-268	100-250	595
1240	∅ 1160	67-174	60-160	495
1440	∅ 1160	46-79	40-70	420

M-PUMPS • 50 Hz

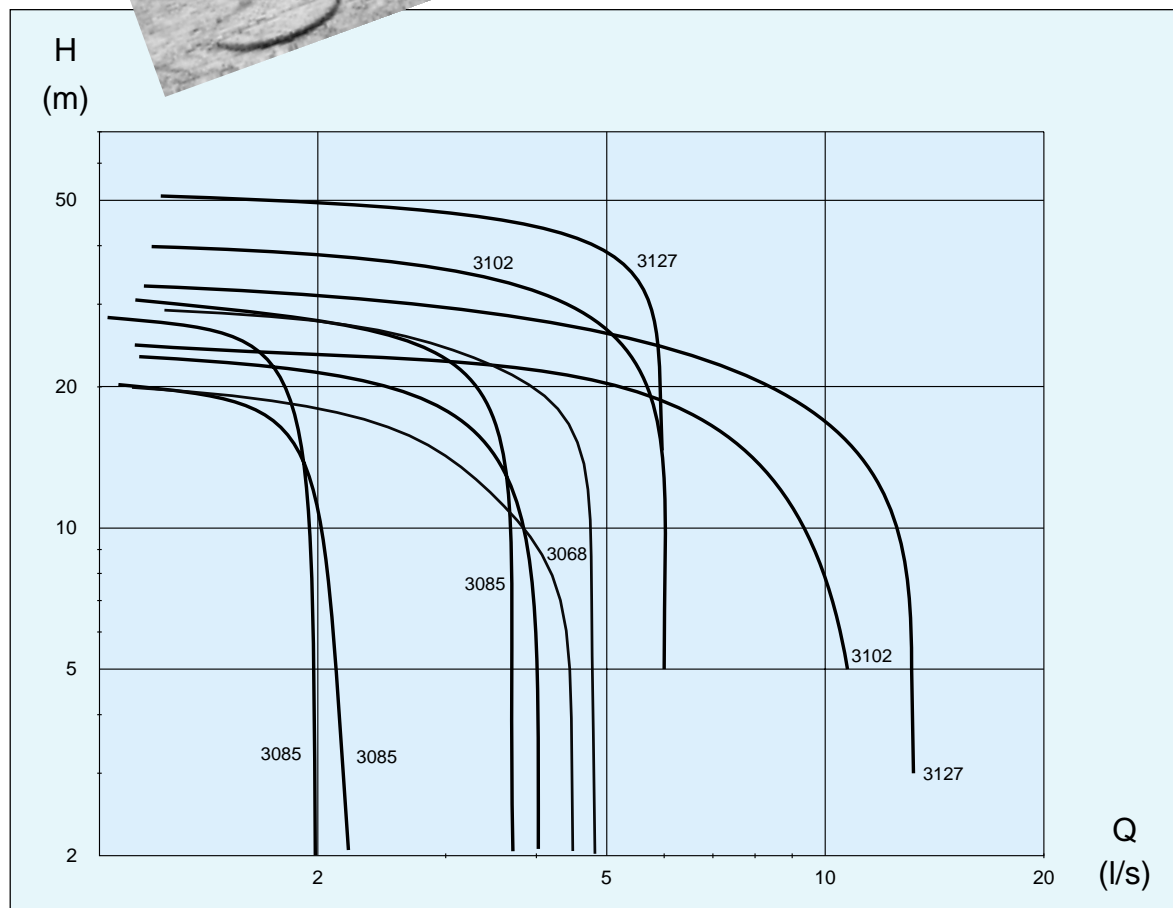
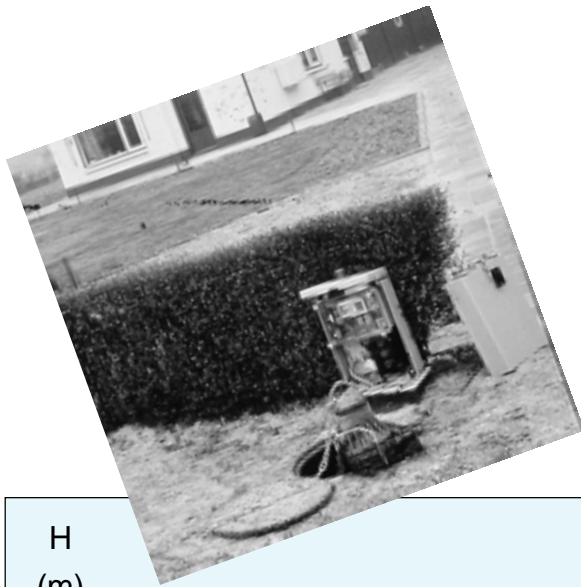

The M-pump features an effective grinder assembly. Specially designed for pressure sewage systems. The vortex impeller is fitted with a cutting device at the inlet.

All solids are reduced to particles no larger than 5 x 15 mm.

The result is a fine slurry that can be pumped through pipes as narrow as 32 mm in diameter.



M 3068

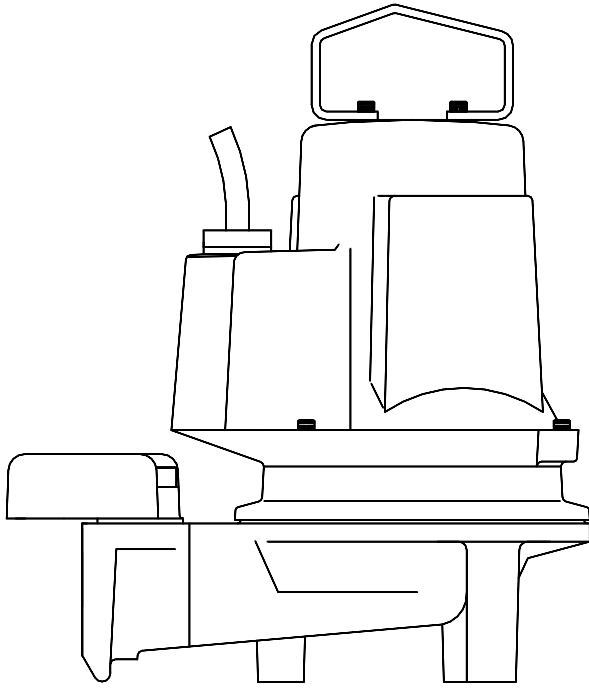

Pump type	MP	MF	MH
Weight, kg	31	31	31

MP/MH/MF

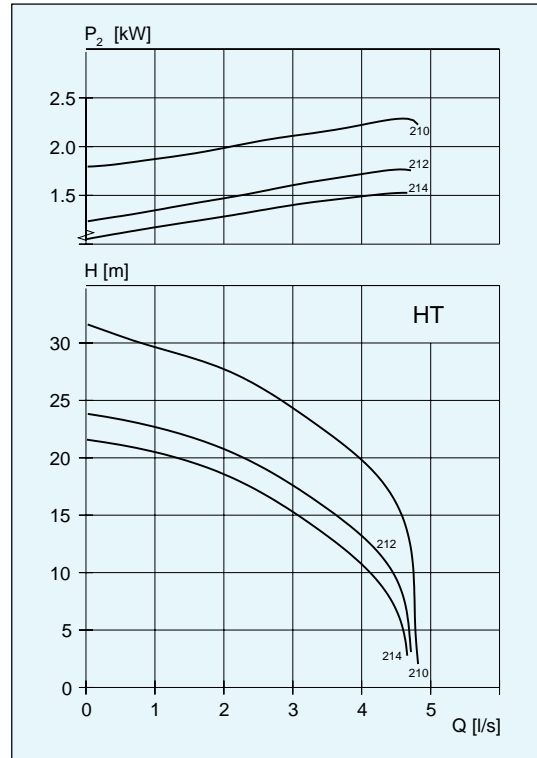

Impeller code	Overall dia mm MP vers	Motor rating, kW		rpm	Available versions
		P ₁	P ₂		
•210	∅ 50	3.2	2.4	2700	MP/MH/MF
•212	∅ 50	3.2	2.4	2700	MP/MH/MF
•212	∅ 50	2.3	1.7	2700	MP/MH/MF
•214	∅ 50	2.3	1.7	2700	MP/MH/MF

• Can be equipped with flush valve

MP/MH/MF

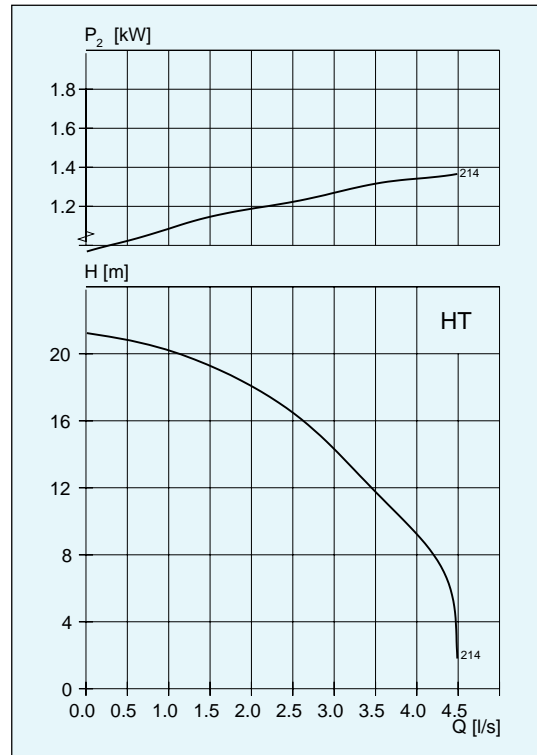

Impeller code	Overall dia mm MP vers	Motor rating, kW		rpm	Available versions
		P ₁	P ₂		
•214*	∅ 50	2.0	1.5	2730	MP/MH/MF

* Single-phase.

M 3085

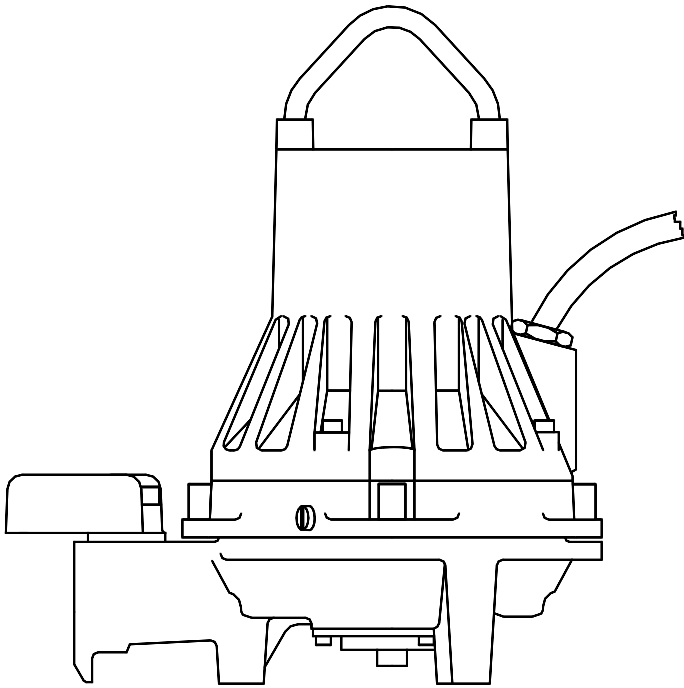

Pump type	MP	MH	MF
Weight, kg	53	52	53

MP/MH/MF

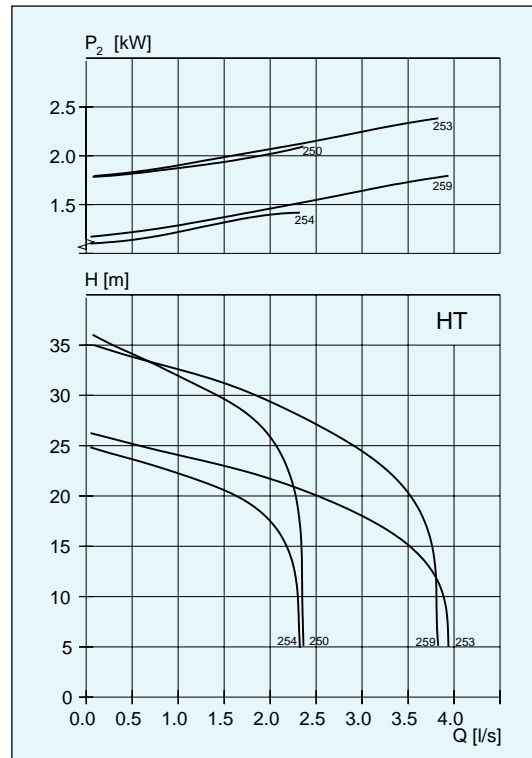

Impeller code	Overall dia mm MP vers	Motor rating, kW		rpm	Available versions
		P ₁	P ₂		
• 250	∅ 50	3.0	2.4	2830	MP/MH/MF
• 253	∅ 50	3.0	2.4	2830	MP/MH/MF
• 254	∅ 50	3.0	2.4	2830	MP/MH/MF
• 254	∅ 50	2.2	1.8	2880	MP/MH/MF
• 259	∅ 50	3.0	2.4	2830	MP/MH/MF
• 259	∅ 50	2.2	1.8	2880	MP/MH/MF

• Can be equipped with flush valve

MP/MH/MF

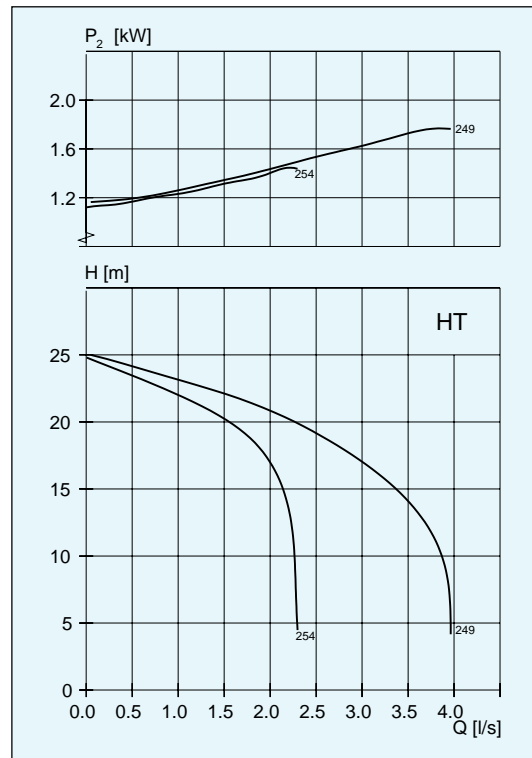

Impeller code	Overall dia mm MP vers	Motor rating, kW		rpm	Available versions
		P ₁	P ₂		
• 249*	∅ 50	2.5	1.9	2915	MP/MH/MF
• 254*	∅ 50	2.5	1.9	2915	MP/MH/MF

* Single-phase.

M 3102

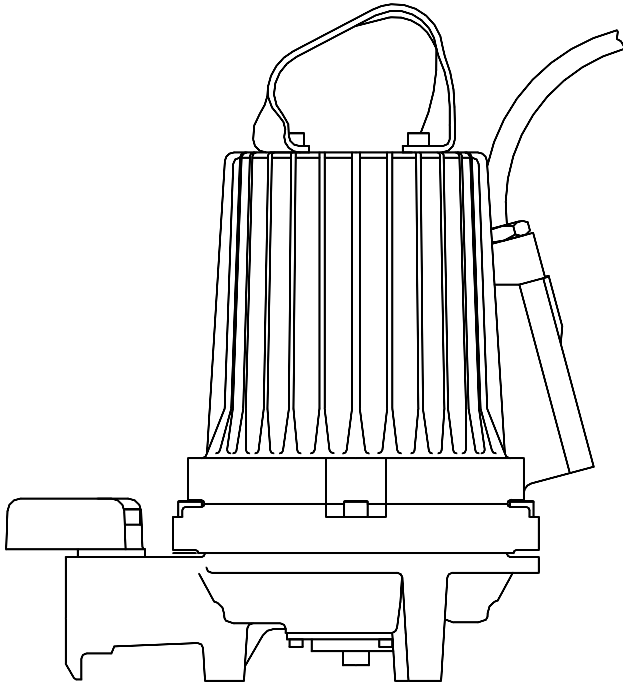

Weight, kg	MP	MF
LT/HT	78	78

MP/MF

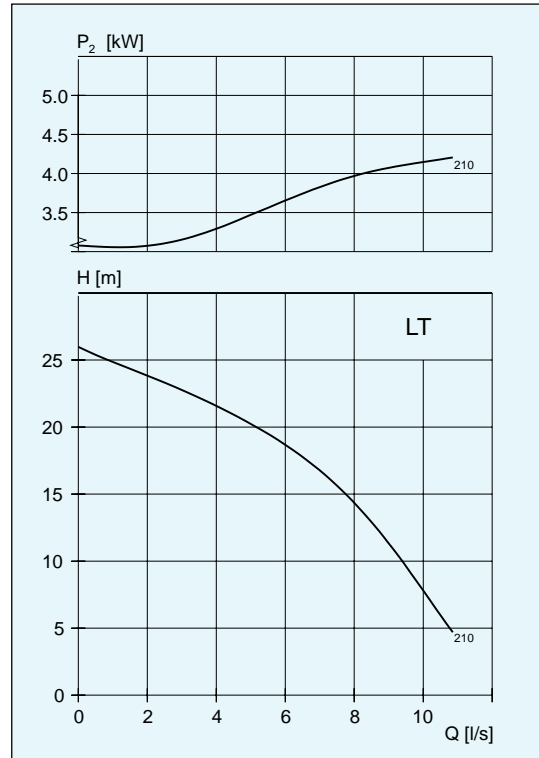

Impeller code	Overall dia mm MP vers	Motor rating, kW		rpm	Available versions
		P ₁	P ₂		
• 210	ISO G2/2" NPT	5.4	4.4	2870	MP/MF

• Can be equipped with flush valve

MP/MF

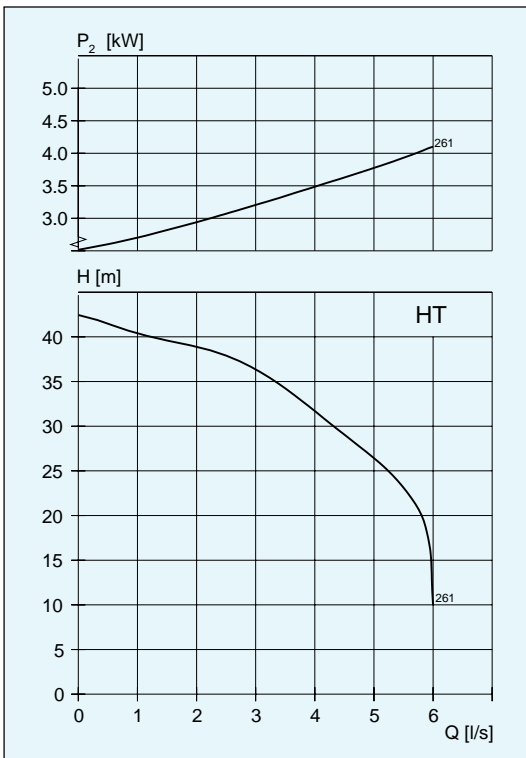

Impeller code	Overall dia mm MP vers	Motor rating, kW		rpm	Available versions
		P ₁	P ₂		
• 261	ISO G2/2" NPT	5.4	4.4	2870	MP/MF

M 3127

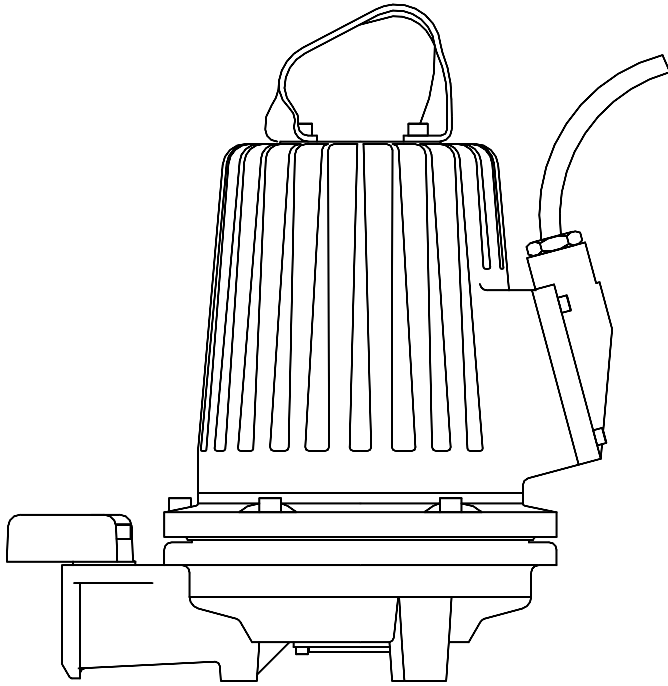

Weight, kg	MP	MF
LT/HT	109	109

MP/MF

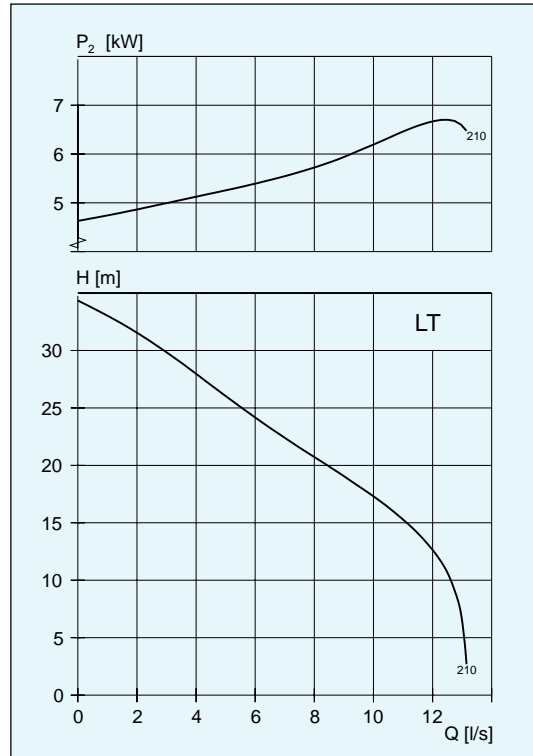

Impeller code	Overall dia mm MP vers	Motor rating, kW		rpm	Available versions
		P_1	P_2		
• 210	∅ 50	8.7	7.4	2905	MP/MF

• Can be equipped with flush valve

MP/MF

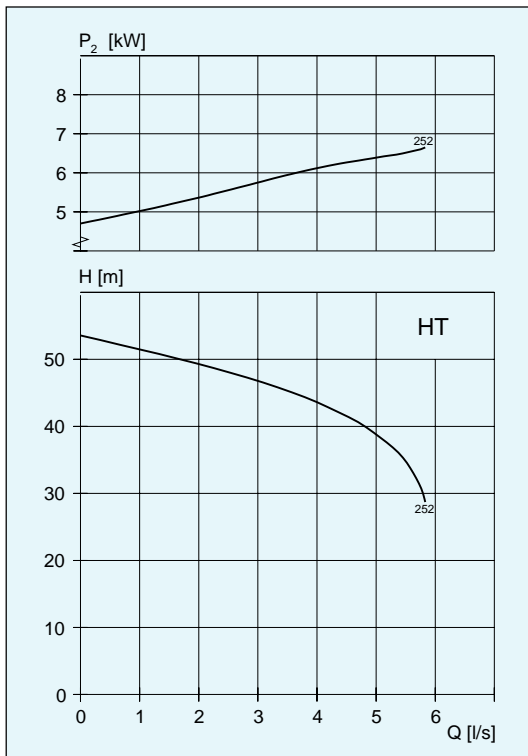

Impeller code	Overall dia mm MP vers	Motor rating, kW		rpm	Available versions
		P_1	P_2		
252	∅ 50	8.7	7.4	2905	MP/MF

MIXERS • 50 Hz

4400

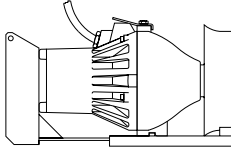

Motor		
Single phase	Max. power, input:	1.8 kW
	Rated power, output:	1.3 kW
	Speed:	1440 RPM
3-phase	Max. power, input:	1.3 kW
	Rated power, output:	0.9 kW
	Speed:	930* RPM
3-phase	Max. power, input:	1.8 kW
	Rated power, output:	1.3 kW
	Speed:	1385* RPM
3-phase	Max. power, input:	3.1 kW
	Rated power, output:	2.3 kW
	Speed:	1375* RPM
WEIGHT:	43 kg	

4410

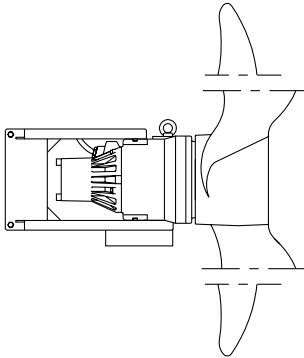

Motor		
3-phase	Max. power, input:	1.3 kW
	Rated power, output:	0.9 kW
	Speed:	930* RPM
3-phase	Max. power, input:	3.1 kW
	Rated power, output:	2.3 kW
	Speed:	1375* RPM
WEIGHT:	250 kg	
MIXER SPEED:	17-40 RPM	

4430

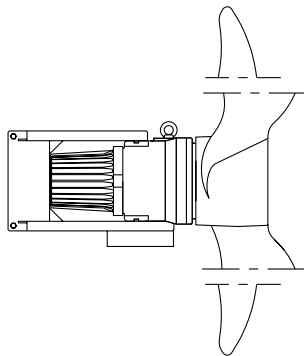

Motor		
3-phase	Max. power, input:	5.0 kW
	Rated power, output:	4.0 kW
	Speed:	1405* RPM
3-phase	Max. power, input:	5.4 kW
	Rated power, output:	4.4 kW
	Speed:	2875* RPM
WEIGHT:	280 kg	
MIXER SPEED:	32-54 RPM	

4610

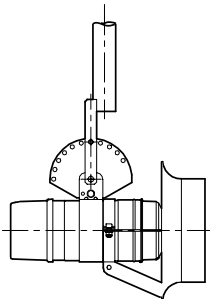

Motor		
3-phase	Max. power, input:	1.0 kW
	Rated power, output:	0.75 kW
	Speed:	1385* RPM
WEIGHT:	16.2 kg	

4620

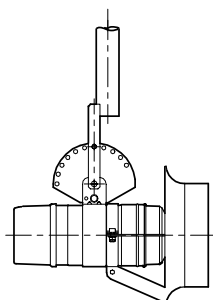

Motor		
3-phase	Max. power, input:	2.2 kW
	Rated power, output:	1.5 kW
	Speed:	1350* RPM
WEIGHT:	17.5 kg	

* 400 V

4630

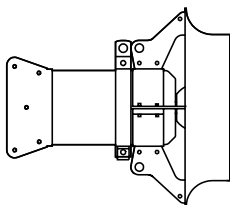

Motor		
3-phase	Max. power, input: Rated power, output: Speed:	2.1 kW 1.5 kW 705* RPM
WEIGHT:	60 kg (incl. jetring)	

4640

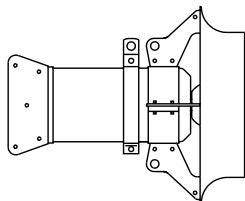

Motor		
3-phase	Max. power, input: Rated power, output: Speed:	3.4 kW 2.5 kW 705* RPM
WEIGHT:	70 kg (incl. jetring)	

4650

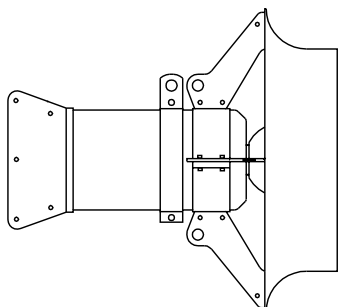

Motor		
3-phase	Max. power, input: Rated power, output: Speed:	6.9 kW 5.0 kW 480* RPM
WEIGHT:	175 kg (incl. jetring)	

4660

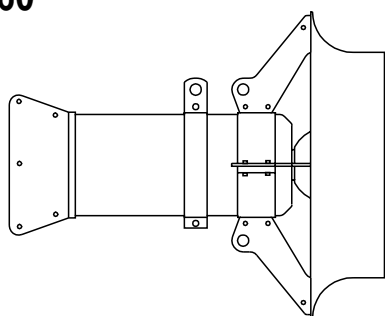

Motor		
3-phase	Max. power, input: Rated power, output: Speed:	13.4 kW 10.0 kW 475* RPM
WEIGHT:	220 kg (incl. jetring)	

4670

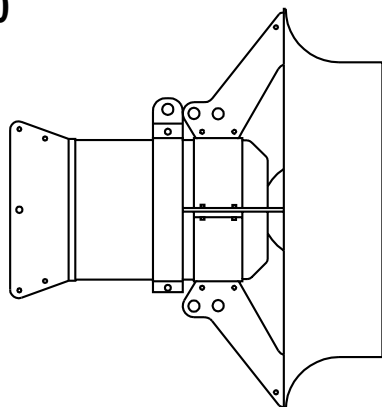

Motor		
3-phase	Max. power, input: Rated power, output: Speed:	17.1 kW 13.0 kW 360* RPM
WEIGHT:	350 kg (incl. jetring)	

4680

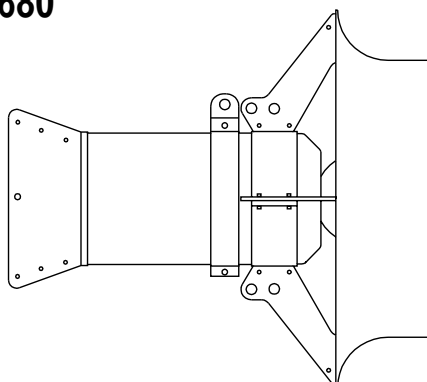

Motor		
3-phase	Max. power, input: Rated power, output: Speed:	32 kW 25 kW 360* RPM
WEIGHT:	470 kg (incl. jetring)	

* 400 V

Submersible mixers (overview of selection)

Mixing Range Chart

	4400	4410/ 4430	4610	4620	4630	4640	4650	4660	4670	4680
Aeration basins	×	■	▲	×	×	×	●	■	■	★
Dinitrification tanks	×	■	▲	×	×	×	●	■	■	★
Flocculation	○	■	○	○	○	○	○	○	○	○
Digesters	○	○	○	×	×	●	●	■	■	★
Sludge homogenizing 5 %	□	○	○	▲	▲	×	●	●	■	★
Neutralization	●	★	×	●	●	■	■	★	★	★
Stormwater retention basins	×	○	▲	×	×	×	●	■	★	★
Liquid manure	▲	○	○	×	×	●	●	■	■	★
Biological processes	▲	○	○	▲	×	×	●	■	■	★
Paper pulp 3-4 %	□	○	○	□	□	□	□	▲	▲	×
Lime slurry 40 %	□	○	○	□	□	□	▲	×	●	■
Other mineral slurries 40 %	□	○	○	□	□	□	▲	×	●	■
Cooling basins	□	○	□	□	□	▲	×	×	●	■
Blending (0.5 h, visc. <500 cp)	×	■	×	×	×	●	■	★	★	★
Blending (0.5 h, visc. >500 cp)	×	●	▲	×	×	×	●	●	●	■
Ice prevention	*	*	*	*	*	*	*	*	*	*
Spray painting plants	▲	○	□	▲	▲	×	×	●	○	○
Emptying of lagoons	**	**	**	**	**	**	**	**	**	**
Destratification & prevention of crust buildup	★	★	■	★	★	★	★	★	★	★

Volume ranges:

Volumes are indicated for one single mixer unit. Volumes for applications not listed will depend on: tank configuration, variations in liquid consistency, proper positioning of the mixer(s) and on unusual local conditions.

○ Normally not applicable

□ 0- 30 m³

▲ 20- 100 m³

×

● 200-1000 m³

■ 600-3000 m³

★ 2000- m³

* Open water surface area, ranging from 0 to 5000 m² depending on mixer and conditions.

** **Partial (localized) mixing.**
Sizing dependent on slurry quality and pumping capacity.

Materials of construction

ITT Flygt offers a wide range of suitable materials of construction. In addition to the standard models in high quality, pressure-resistant cast iron, models are available also in acid- and corrosion-resistant stainless steel. Modular design allows the selective assembly of parts in various material combinations.

Note:

The above values are recommended only, based on empirical data. For detailed information contact your nearest FLYGT Sales Office. A mixer application specialist will analyze your data and, using the latest in computer software technology, will provide exact specifications, selection and layout most suitable and most economical for your particular application.

N-PUMPS • 50 Hz

SMALL AND MEDIUM SIZE

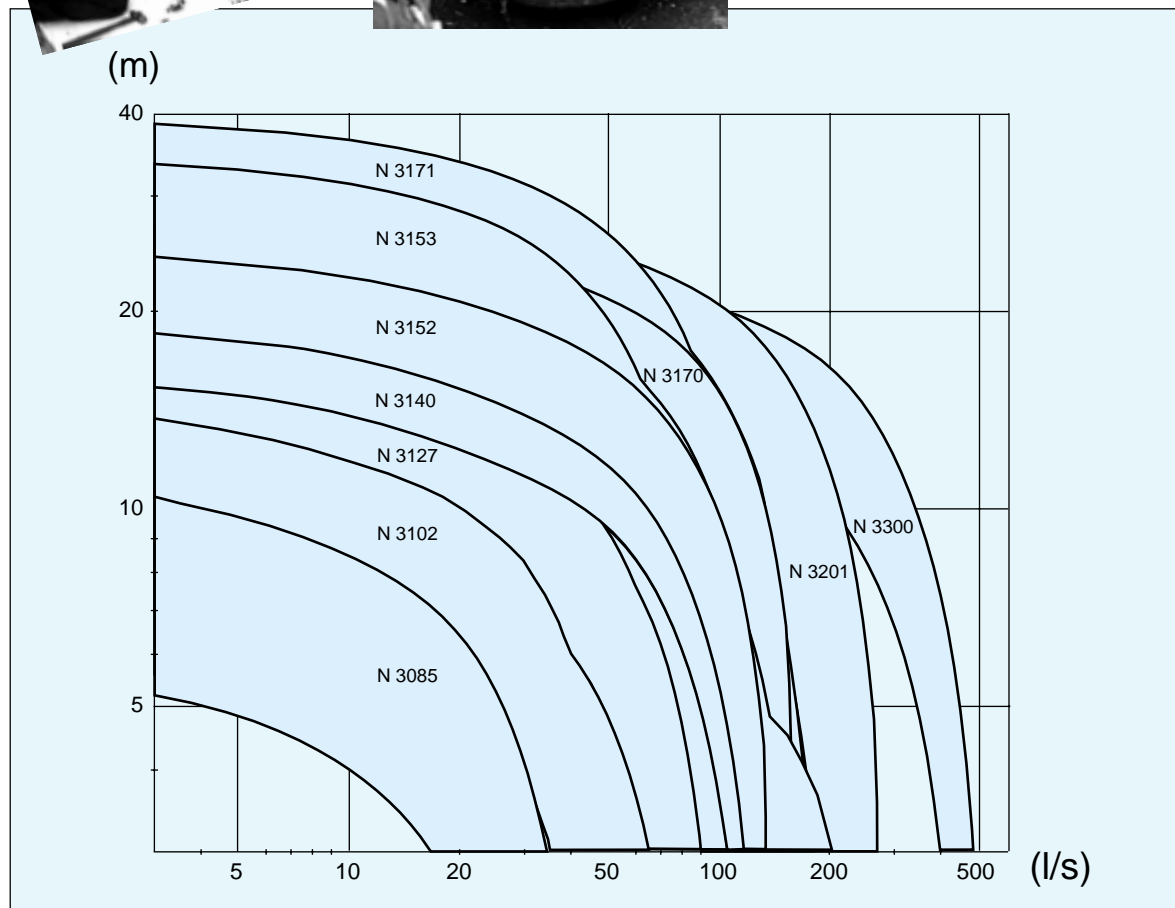

The state of the art impeller design for waste water. Excellent clog resistance is combined with high efficiency. The high efficiency is maintained over time due to the self cleaning design incorporating heavily back swept leading edges and a relief groove in the volute.



N 3085

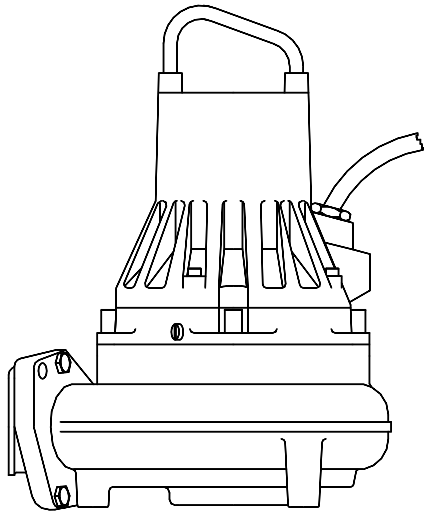

Weight, kg	NP	NS	NT	NZ
MT	66	68	71	88

NP/NS/NT/NZ

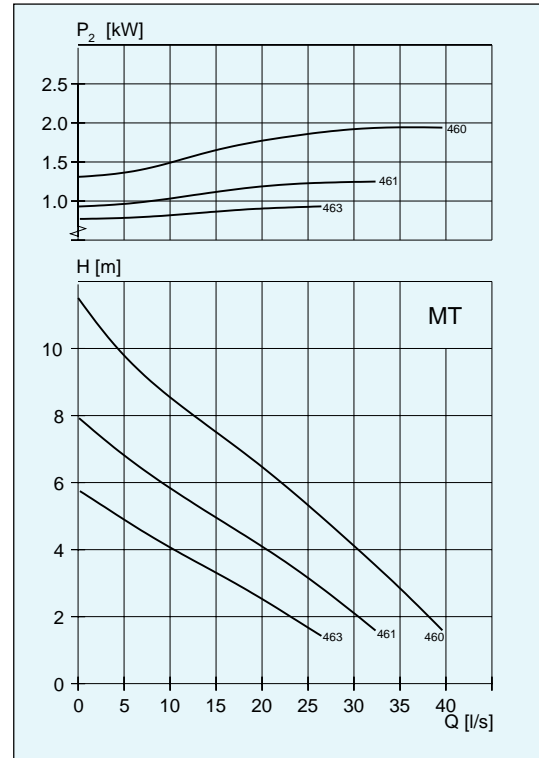

Impeller code	No. of vanes	Outlet dia mm NP vers.	Motor rating kW		rpm	Available versions
			P_1	P_2		
• 460	2	80/100	2.7	2.0	1395	NP/NS/NT/NZ
• W461	2	80/100	2.7	2.0	1395	NP/NS/NT/NZ
• W463	2	80/100	2.7	2.0	1395	NP/NS/NT/NZ
• 461*	2	80/100	2.0	1.5	1440	NP/NS/NT/NZ
• 463*	2	80/100	2.0	1.5	1440	NP/NS/NT/NZ

- * Single-phase
- Can be equipped with flush valve

N 3102

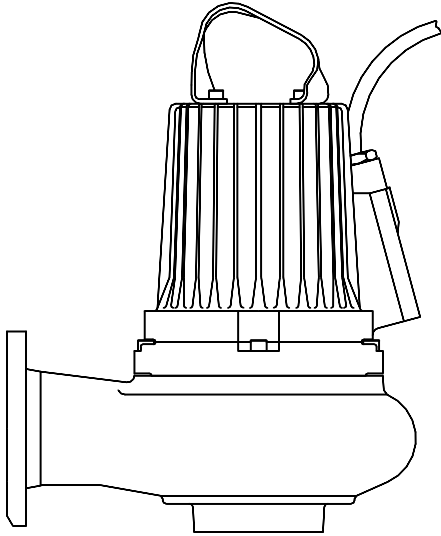

Weight, kg	NP	NS	NT	NZ
LT	120	138	166	209
MT	107	116	154	191

NP/NS/NT/NZ

NP/NS/NT/NZ

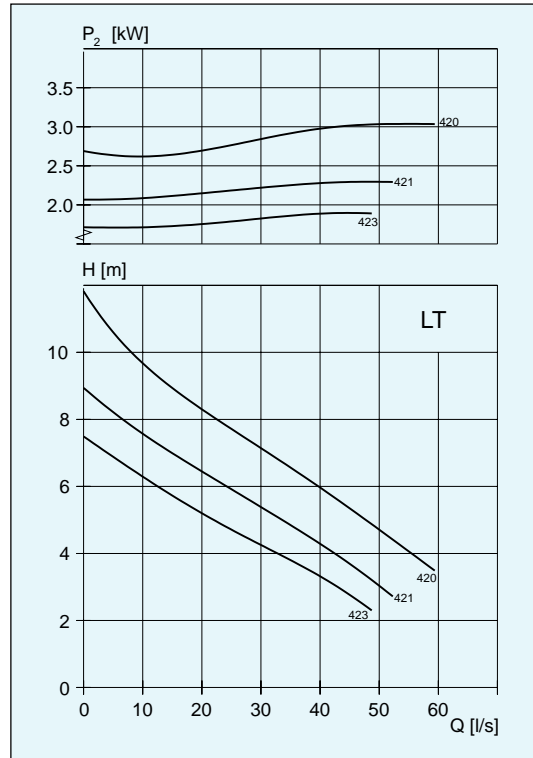

Impeller code	No. of vanes	Outlet dia mm NP vers.	Motor rating kW		rpm	Available versions
			P ₁	P ₂		
•W420	2	150	3.8	3.1	1435	NPNS
•W421	2	150	3.8	3.1	1435	NPNS
•W423	2	150	3.8	3.1	1435	NPNS
420	2	150	2.9	2.4	1450	NT/NZ
421	2	150	2.9	2.4	1450	NT/NZ
423	2	150	2.9	2.4	1450	NT/NZ

• Can be equipped with flush valve

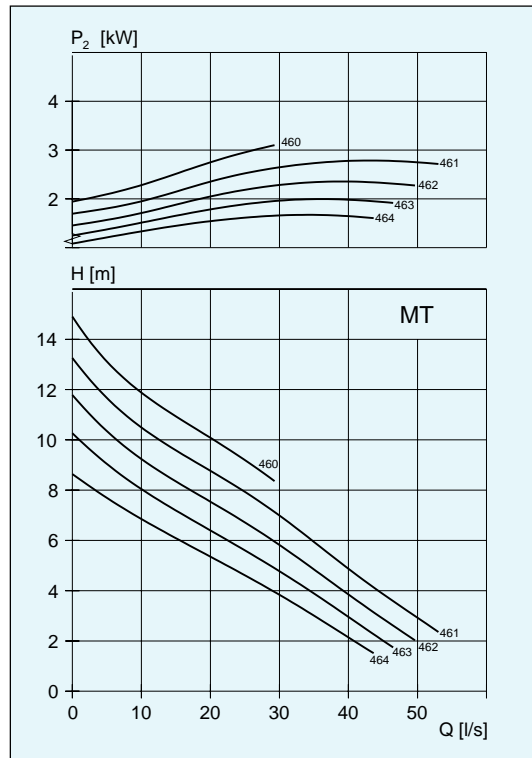

Impeller code	No. of vanes	Outlet dia mm NP vers.	Motor rating kW		rpm	Available versions
			P ₁	P ₂		
•W460	2	150	3.8	3.1	1435	NPNS
•W461	2	150	3.8	3.1	1435	NPNS
•W462	2	150	3.8	3.1	1435	NPNS
•W463	2	150	3.8	3.1	1435	NPNS
•W464	2	150	3.8	3.1	1435	NPNS
460	2	150	2.9	2.4	1450	NT/NZ
461	2	150	2.9	2.4	1450	NT/NZ
462	2	150	2.9	2.4	1450	NT/NZ
463	2	150	2.9	2.4	1450	NT/NZ
464	2	150	2.9	2.4	1450	NT/NZ

N 3127

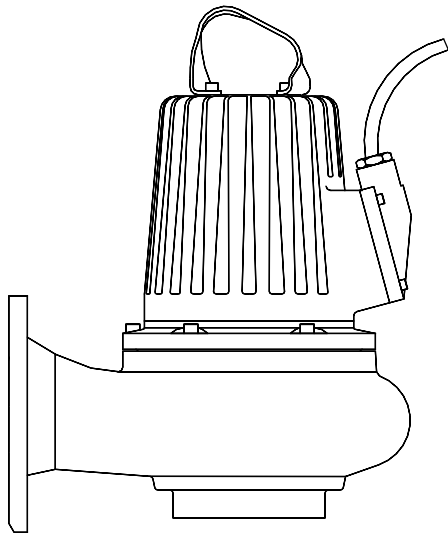

Weight, kg	NP	NS	NT	NZ
LT	154	183	220	220
MT	142	158	188	188

NP/NS/NT/NZ

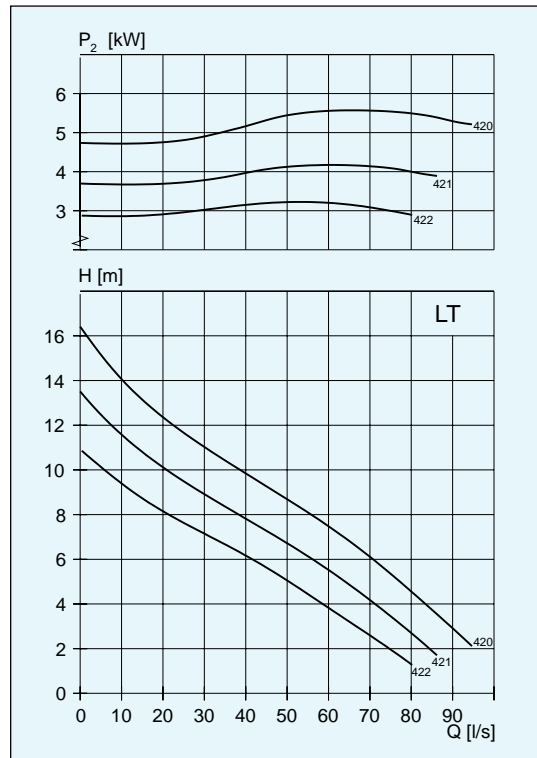

Impeller code	No. of vanes	Outlet dia mm NP vers.	Motor rating kW		rpm	Available versions
			P ₁	P ₂		
• 420	2	150	7.0	5.9	1450	NPNS
• W421	2	150	7.0	5.9	1450	NPNS
• 421	2	150	5.7	4.7	1445	NPNS
• W422	2	150	7.0	5.9	1445	NPNS
• 422	2	150	5.7	4.7	1445	NPNS
421	2	150	5.7	4.7	1445	NTNZ
422	2	150	5.7	4.7	1445	NTNZ
421	2	150	4.8	4.0	1445	NTNZ
422	2	150	4.8	4.0	1445	NTNZ

NP/NS/NT/NZ

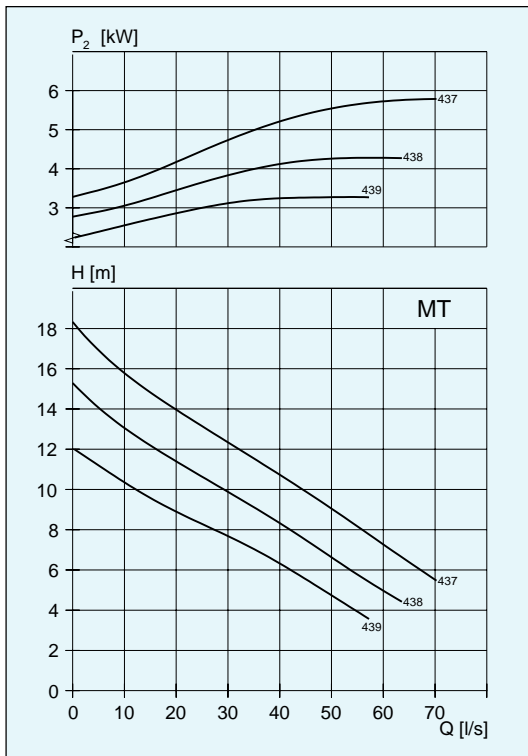

Impeller code	No. of vanes	Outlet dia mm NP vers.	Motor rating kW		rpm	Available versions
			P ₁	P ₂		
• W437	2	100/150	7.0	5.9	1450	NPNS
• W438	2	100/150	7.0	5.9	1450	NPNS
• 438	2	100/150	5.7	4.7	1445	NPNS
• W439	2	100/150	7.0	5.9	1445	NPNS
• 439	2	100/150	5.7	4.7	1445	NPNS
438	2	100/150	5.7	4.7	1445	NTNZ
439	2	100/150	5.7	4.7	1445	NTNZ
439	2	100/150	4.8	4.0	1445	NTNZ

- Can be equipped with flush valve

N 3127

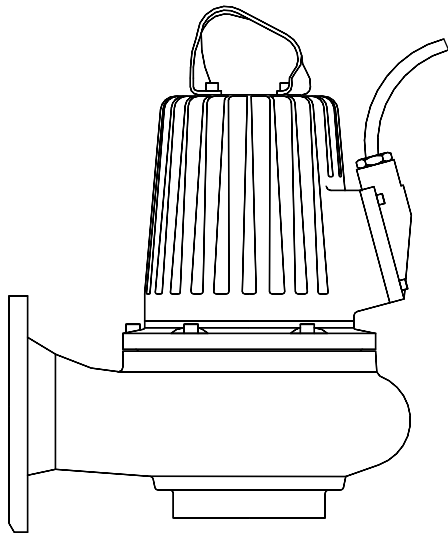

Weight, kg	NP	NS	NT	NZ
HT	136	142	156	200

NP/NS/NT/NZ

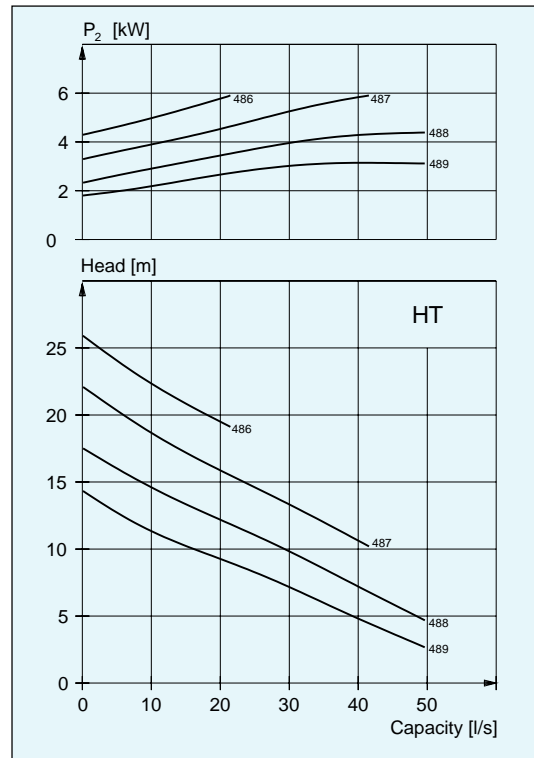

Impeller code	No. of vanes	Outlet dia mm NP vers.	Motor rating kW		rpm	Available versions
			P ₁	P ₂		
•486	2	100	7.0	5.9	1450	NPNS
•486	2	100	5.7	4.7	1445	NPNS
•487	2	100	7.0	5.9	1450	NPNS
•487	2	100	5.7	4.7	1445	NPNS
•W488	2	100	7.0	5.9	1450	NPNS
•488	2	100	5.7	4.7	1445	NPNS
•W489	2	100	7.0	5.9	1450	NPNS
•489	2	100	5.7	4.7	1445	NPNS
488	2	100	5.7	4.7	1445	NT/NZ
488	2	100	4.8	4.0	1445	NT/NZ
489	2	100	5.7	4.7	1445	NT/NZ
489	2	100	4.8	4.0	1445	NT/NZ

- Can be equipped with flush valve

N 3140

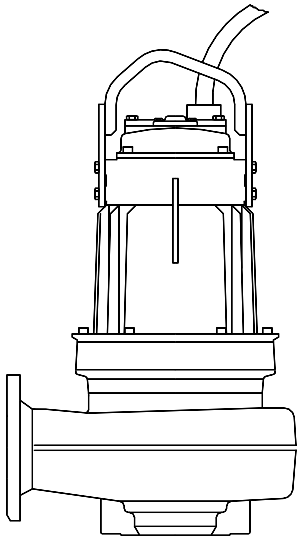

Weight, kg	NP	NS
MT	252	281

NP/NS

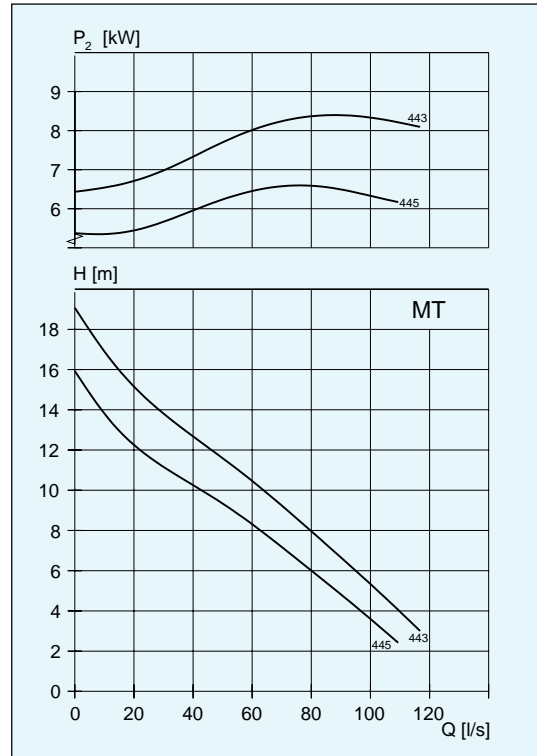

Impeller code	No. of vanes	Outlet dia mm NP vers.	Motor rating kW		rpm	Available versions
			P_1	P_2		
• 443	2	150	10.7	9.0	1455	NP/NS
• 445	2	150	10.7	9.0	1455	NP/NS

• Can be equipped with flush valve

N 3152

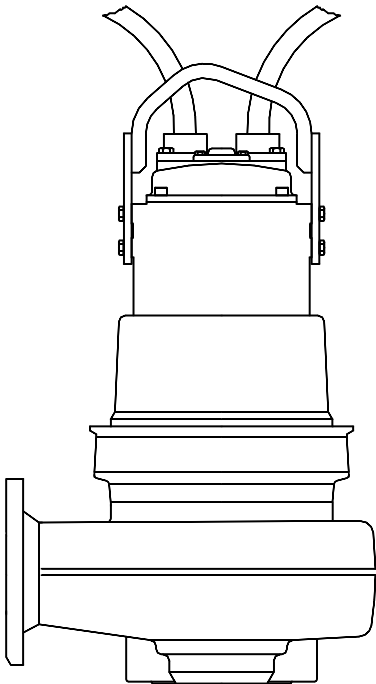

Weight, kg	NP	NS	NT	NZ
MT	279	320	348	348

NP/NS/NT/NZ

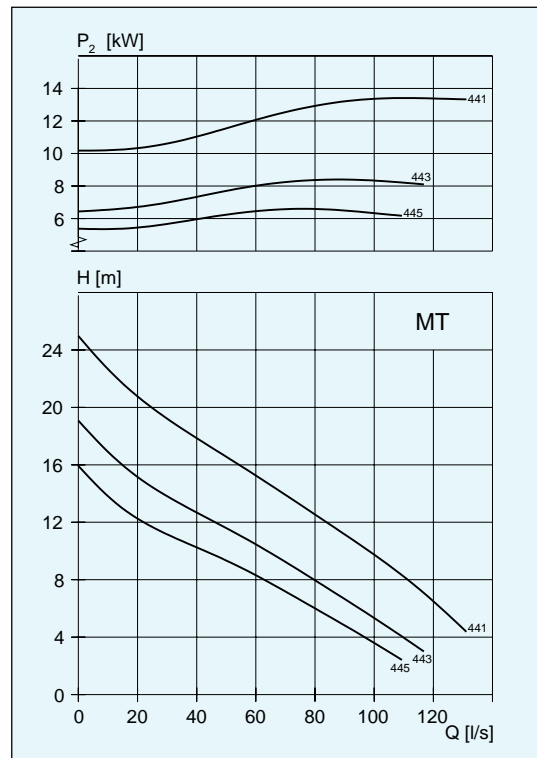

Impeller code	No. of vanes	Outlet dia mm NP vers.	Motor rating kW		rpm	Available versions
			P_1	P_2		
• 441	2	150	15.8	13.5	1450	NP/NS/NT/NZ
• W443	2	150	15.8	13.5	1450	NP/NS/NT/NZ
• 443	2	150	10.7	9.0	1455	NP/NS/NT/NZ
• W445	2	150	15.8	13.5	1450	NP/NS/NT/NZ
• 445	2	150	10.7	9.0	1455	NP/NS/NT/NZ

N 3153

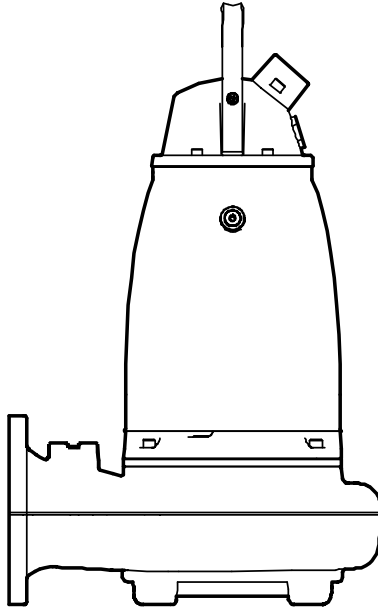

Weight, kg	NP	NS	NT	NZ
LT	239	257	326	327
LT, 6-pole	298	361	417	386
MT	203	232	272	256
HT	189	209	235	232

NP/NS/NT/NZ

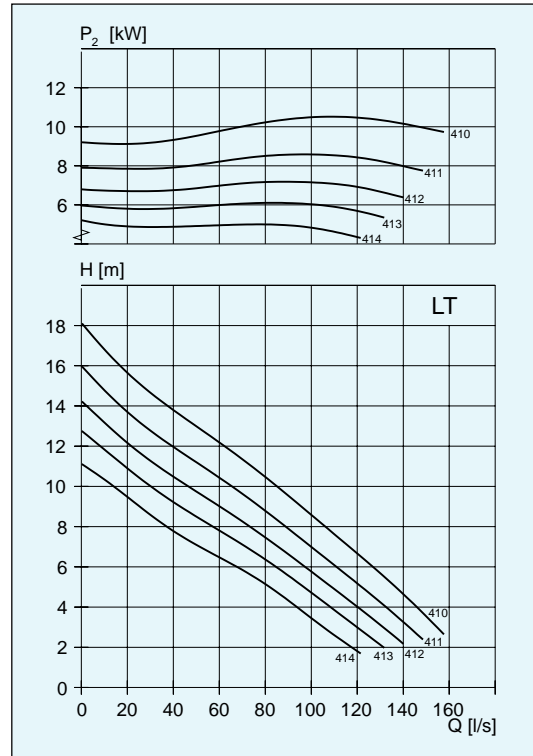

Impeller code	No. of vanes	Outlet dia mm NP vers.	Motor rating kW		rpm	Available versions
			P ₁	P ₂		
•W410	2	200	12.7	11.0	1460	NPNSNTNZ
•W411	2	200	12.7	11.0	1460	NPNSNTNZ
•411	2	200	10.4	9.0	1460	NPNSNTNZ
•W412	2	200	12.7	11.0	1460	NPNSNTNZ
•412	2	200	10.4	9.0	1460	NPNSNTNZ
•412	2	200	8.8	7.5	1460	NPNSNTNZ
•W413	2	200	12.7	11.0	1460	NPNSNTNZ
•413	2	200	10.4	9.0	1460	NPNSNTNZ
•413	2	200	8.8	7.5	1460	NPNSNTNZ
•W414	2	200	12.7	11.0	1460	NPNSNTNZ
•414	2	200	10.4	9.0	1460	NPNSNTNZ
•414	2	200	8.8	7.5	1460	NPNSNTNZ

NP/NS/NT/NZ

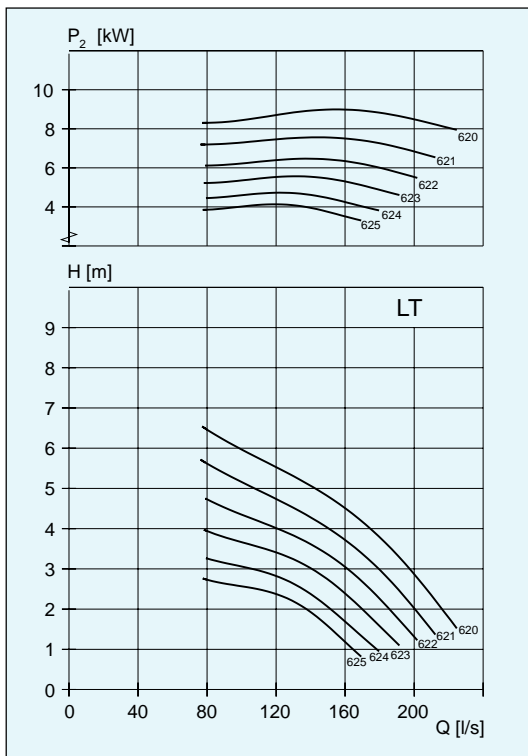

Impeller code	No. of vanes	Outlet dia mm NP vers.	Motor rating kW		rpm	Available versions
			P ₁	P ₂		
•620	2	250	10.5	9.0	955	NPNSNTNZ
•621	2	250	10.5	9.0	955	NPNSNTNZ
•622	2	250	10.5	9.0	955	NPNSNTNZ
•623	2	250	10.5	9.0	955	NPNSNTNZ
•624	2	250	10.5	9.0	955	NPNSNTNZ
•625	2	250	10.5	9.0	955	NPNSNTNZ

• Can be equipped with flush valve

N 3153

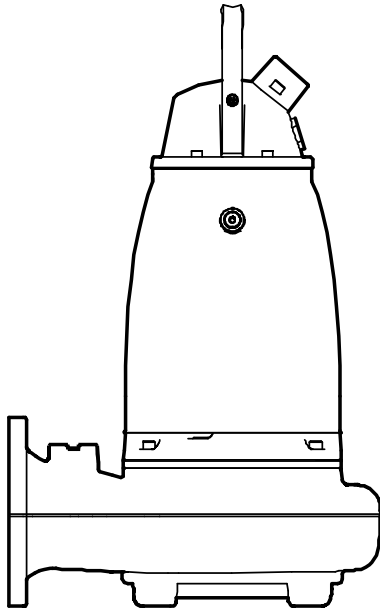

NP/NS/NT/NZ

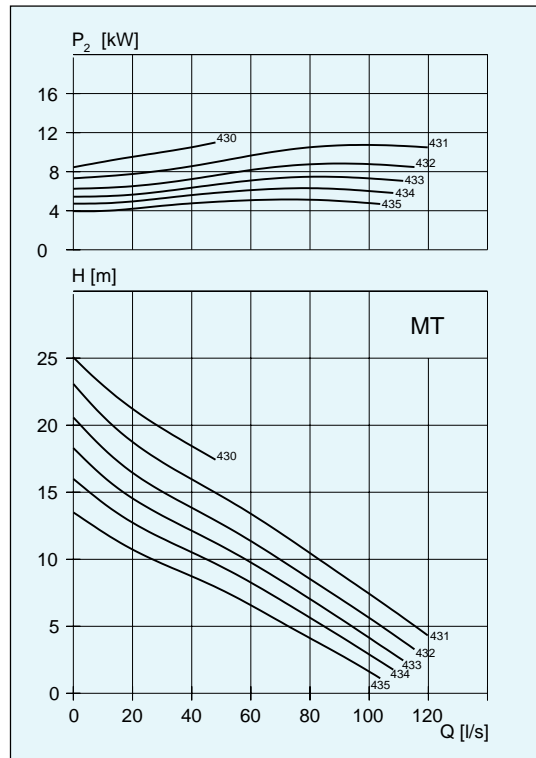

Impeller code	No. of vanes	Outlet dia mm NP vers.	Motor rating kW		rpm	Available versions
			P ₁	P ₂		
• W430	2	150	12.7	11.0	1460	NP/NS/NT/NZ
• W431	2	150	12.7	11.0	1460	NP/NS/NT/NZ
• 431	2	150	10.4	9.0	1460	NP/NS/NT/NZ
• W432	2	150	12.7	11.0	1460	NP/NS/NT/NZ
• 432	2	150	10.4	9.0	1460	NP/NS/NT/NZ
• 432	2	150	8.8	7.5	1460	NP/NS/NT/NZ
• W433	2	150	12.7	11.0	1460	NP/NS/NT/NZ
• 433	2	150	10.4	9.0	1460	NP/NS/NT/NZ
• 433	2	150	8.8	7.5	1460	NP/NS/NT/NZ
• W434	2	150	12.7	11.0	1460	NP/NS/NT/NZ
• 434	2	150	10.4	9.0	1460	NP/NS/NT/NZ
• 434	2	150	8.8	7.5	1460	NP/NS/NT/NZ

NP/NS/NT/NZ

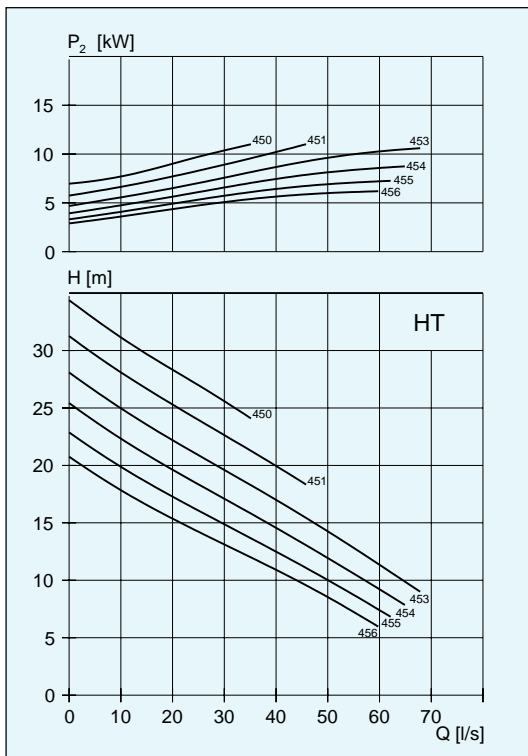

Impeller code	No. of vanes	Outlet dia mm NP vers.	Motor rating kW		rpm	Available versions
			P ₁	P ₂		
• W450	2	100	12.7	11.0	1460	NP/NS/NT/NZ
• W451	2	100	12.7	11.0	1460	NP/NS/NT/NZ
• W453	2	100	12.7	11.0	1460	NP/NS/NT/NZ
• W454	2	100	12.7	11.0	1460	NP/NS/NT/NZ
• 454	2	100	10.4	9.0	1460	NP/NS/NT/NZ
• W455	2	100	12.7	11.0	1460	NP/NS/NT/NZ
• 455	2	100	10.4	9.0	1460	NP/NS/NT/NZ
• 455	2	100	8.8	7.5	1460	NP/NS/NT/NZ
• W456	2	100	12.7	11.0	1460	NP/NS/NT/NZ
• 456	2	100	10.4	9.0	1460	NP/NS/NT/NZ
• 456	2	100	8.8	7.5	1460	NP/NS/NT/NZ

• Can be equipped with flush valve

N 3170

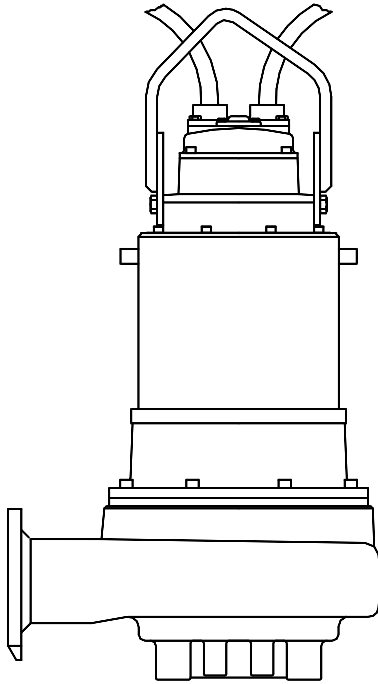

Weight, kg	NP	NS
MT	522	542

NP/NS

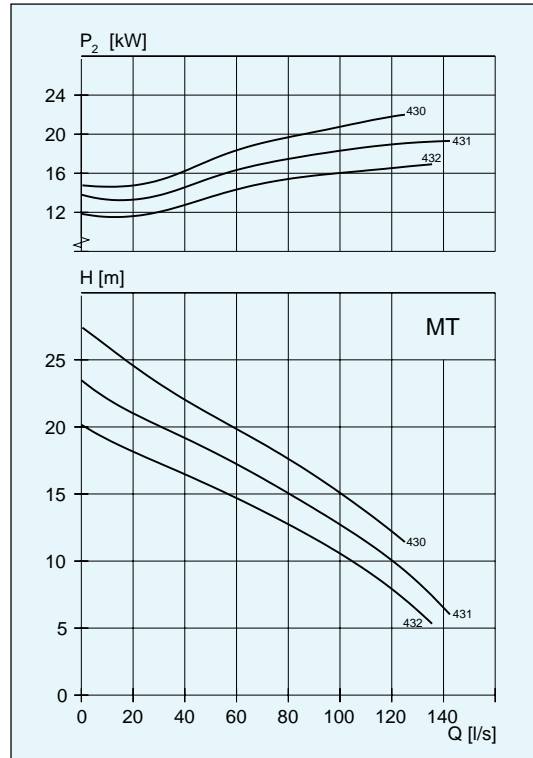

Impeller code	No. of vanes	Outlet dia mm NP vers.	Motor rating kW		rpm	Available versions
			P ₁	P ₂		
• 430	2	150	25	22	1460	NP/NS
• 431	2	150	25	22	1460	NP/NS
• 432	2	150	25	22	1460	NP/NS

• Can be equipped with flush valve

NP/NS

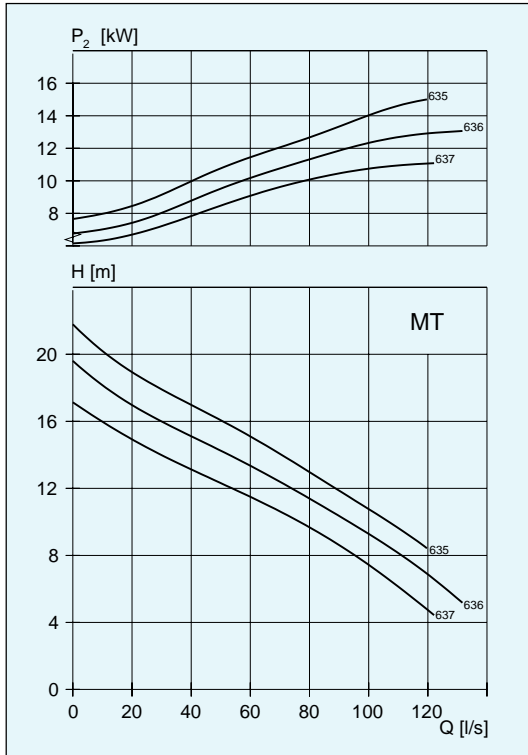

Impeller code	No. of vanes	Outlet dia mm NP vers.	Motor rating kW		rpm	Available versions
			P ₁	P ₂		
• 635	2	150	17.5	15	1460	NP/NS
• 636	2	150	17.5	15	1460	NP/NS
• 637	2	150	17.5	15	1460	NP/NS

N 3171

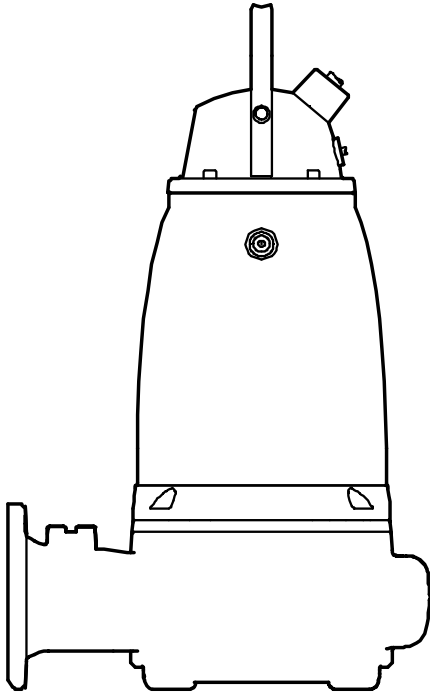

Weight, kg	NP	NS	NT
MT	312	345	399
HT	290	310	359

NP/NS/NT/NZ

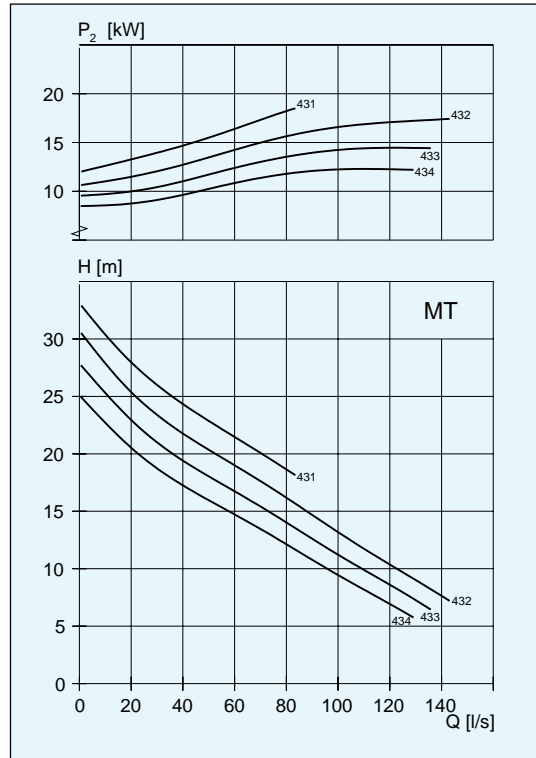

Impeller code	No. of vanes	Outlet dia mm NP vers.	Motor rating kW		rpm	Available versions
			P ₁	P ₂		
•W431	2	150	21.0	18.5	1460	NP/NS/NT/NZ
•W432	2	150	21.0	18.5	1460	NP/NS/NT/NZ
•W433	2	150	21.0	18.5	1460	NP/NS/NT/NZ
•433	2	150	17.2	15.0	1460	NP/NS/NT/NZ
•W434	2	150	21.0	18.5	1460	NP/NS/NT/NZ
•434	2	150	17.2	15.0	1460	NP/NS/NT/NZ
•434	2	150	15.1	13.0	1460	NP/NS/NT/NZ

NP/NS/NT/NZ

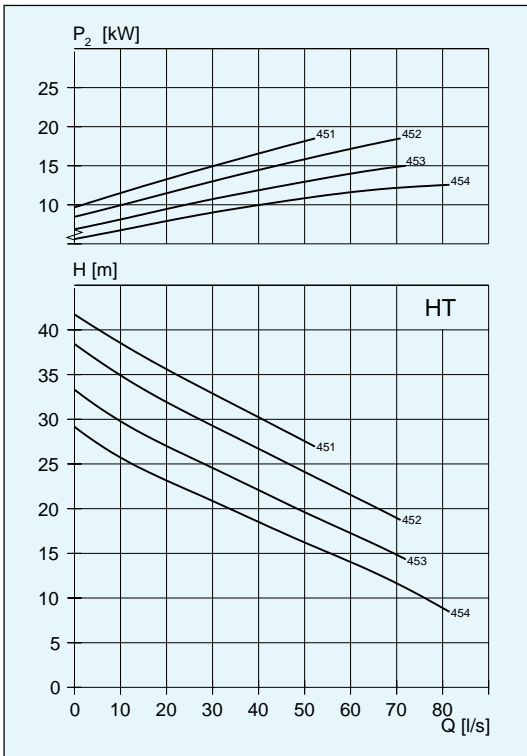

Impeller code	No. of vanes	Outlet dia mm NP vers.	Motor rating kW		rpm	Available versions
			P ₁	P ₂		
•W451	2	100	21.0	18.5	1460	NP/NS/NT/NZ
•W452	2	100	21.0	18.5	1460	NP/NS/NT/NZ
•W453	2	100	21.0	18.5	1460	NP/NS/NT/NZ
•453	2	100	17.2	15.0	1460	NP/NS/NT/NZ
•W454	2	100	21.0	18.5	1460	NP/NS/NT/NZ
•454	2	100	17.2	15.0	1460	NP/NS/NT/NZ
•454	2	100	15.1	13.0	1460	NP/NS/NT/NZ

• Can be equipped with flush valve

N 3201

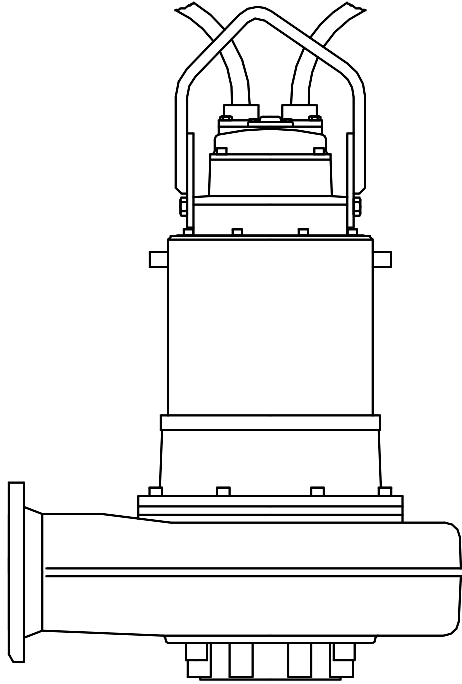

Weight, kg	NP	NS	NT	NZ
MT	570	598	635	635

NP/NS/NT/NZ

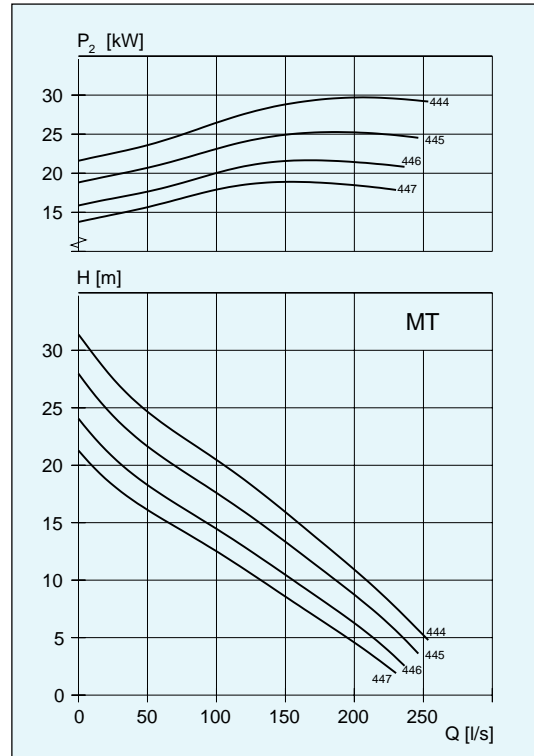

Impeller code	No. of vanes	Outlet dia mm NP vers.	Motor rating kW		rpm	Available versions
			P ₁	P ₂		
• 444	2	200	34	30	1455	NPNSNTNZ
• 445	2	200	34	30	1455	NPNSNTNZ
• 446	2	200	34	30	1455	NPNSNTNZ
• 446	2	200	25	22	1460	NPNSNTNZ
• 447	2	200	34	30	1455	NPNSNTNZ
• 447	2	200	25	22	1460	NPNSNTNZ

• Can be equipped with flush valve

NP/NS/NT/NZ

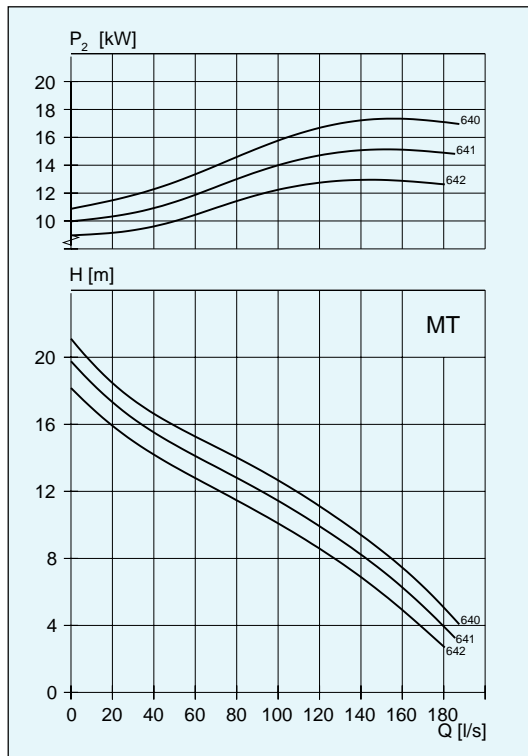

Impeller code	No. of vanes	Outlet dia mm NP vers.	Motor rating kW		rpm	Available versions
			P ₁	P ₂		
• W640	2	200	25	22	1460	NPNSNTNZ
• W641	2	200	25	22	1460	NPNSNTNZ
• W642	2	200	25	22	1460	NPNSNTNZ

N 3300

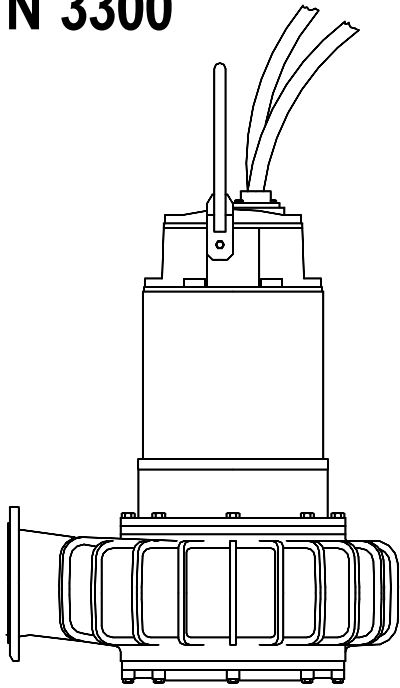

Weight, kg	NP	NS	NT	NZ
LT	1065	1180	1313	1313
MT	1092	1207	1340	1340

NP/NS/NT/NZ

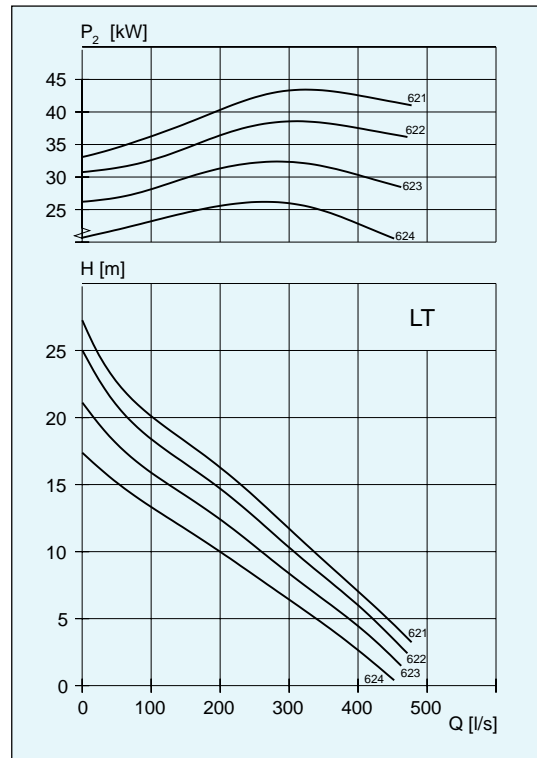

Impeller code	No. of vanes	Outlet dia mm NP vers.	Motor rating kW		rpm	Available versions
			P ₁	P ₂		
• 621	2	300	50	44	975	NP/NS/NT/NZ
• 622	2	300	50	44	975	NP/NS/NT/NZ
• 623	2	300	50	44	975	NP/NS/NT/NZ
• 623	2	300	39	34	975	NP/NS/NT/NZ
• 624	2	300	50	44	975	NP/NS/NT/NZ
• 624	2	300	39	34	975	NP/NS/NT/NZ

• Can be equipped with flush valve

NP/NS/NT/NZ

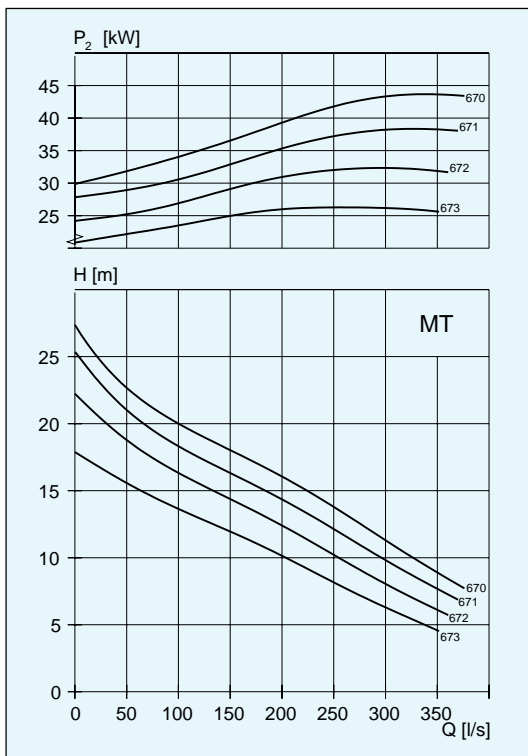

Impeller code	No. of vanes	Outlet dia mm NP vers.	Motor rating kW		rpm	Available versions
			P ₁	P ₂		
• 670	2	250	50	44	975	NP/NS/NT/NZ
• 671	2	250	50	44	975	NP/NS/NT/NZ
• 672	2	250	50	44	975	NP/NS/NT/NZ
• 672	2	250	39	34	975	NP/NS/NT/NZ
• 673	2	250	50	44	975	NP/NS/NT/NZ
• 673	2	250	39	34	975	NP/NS/NT/NZ

PP 4600

PROPELLER-PUMPS • 50 Hz

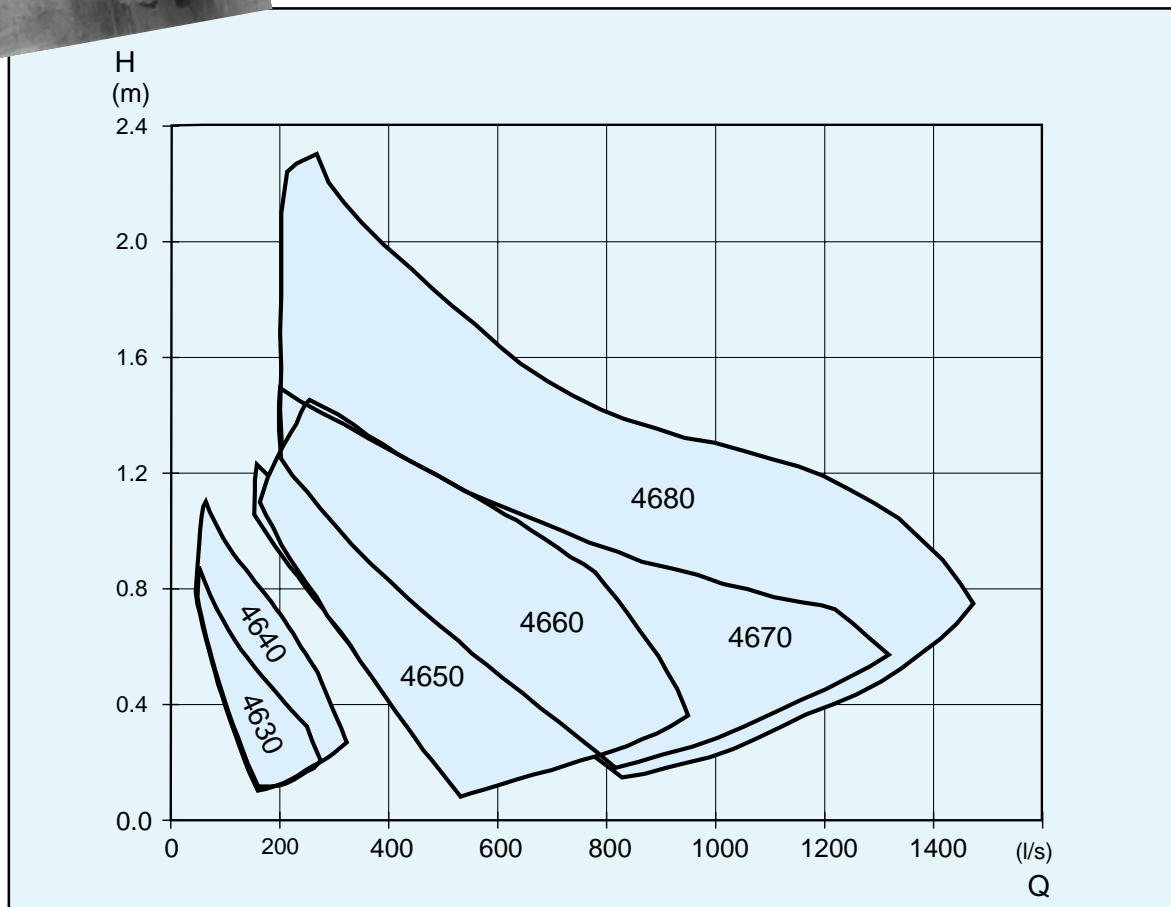
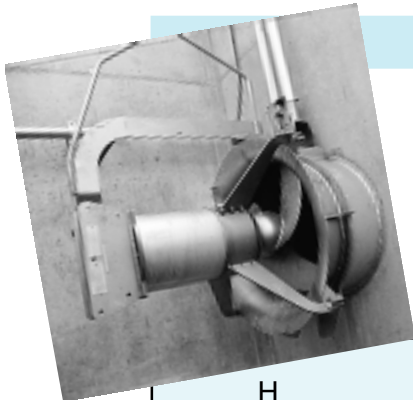

The 4600 propeller pump is designed for applications requiring very large capacity at ultra low head.



PP 4630

3-phase

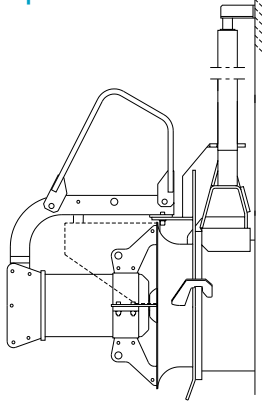

Max. power, input	2.1 kW
Rated power, output	1.5 kW
Speed	750* r/min
Weight	77 kg

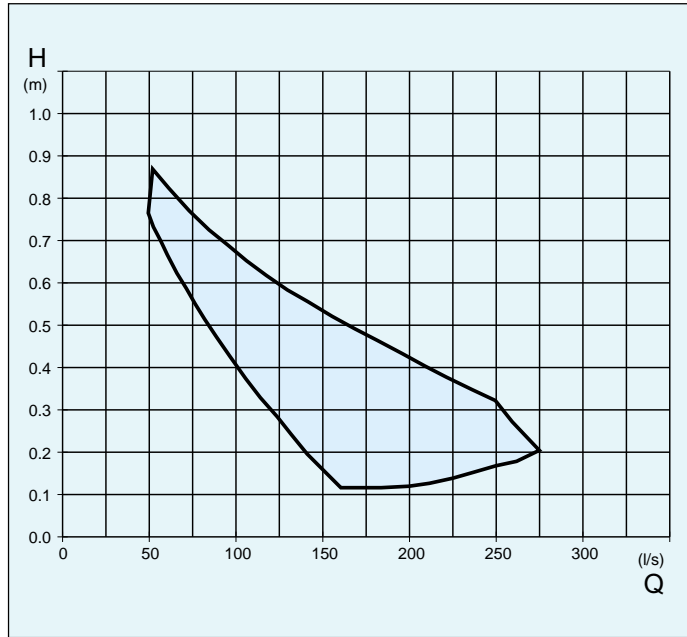

PP 4640

3-phase

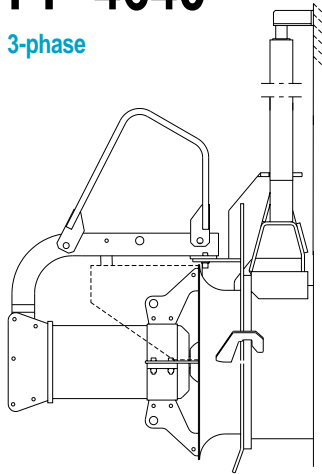

Max. power, input	3.4 kW
Rated power, output	2.5 kW
Speed	705* r/min
Weight	83 kg

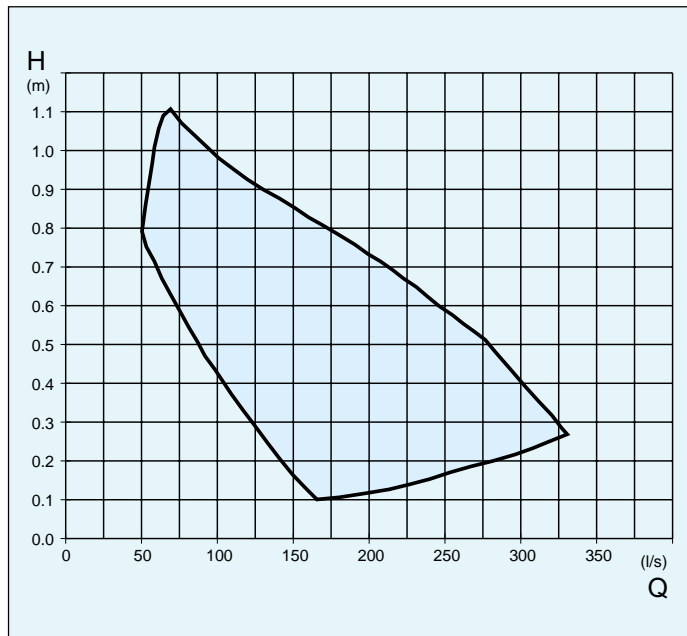

*400V

PP 4650

3-phase

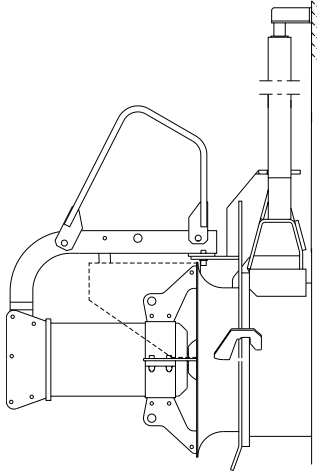

Max. power, input	6.9 kW
Rated power, output	5 kW
Speed	480* r/min
Weight	196 kg

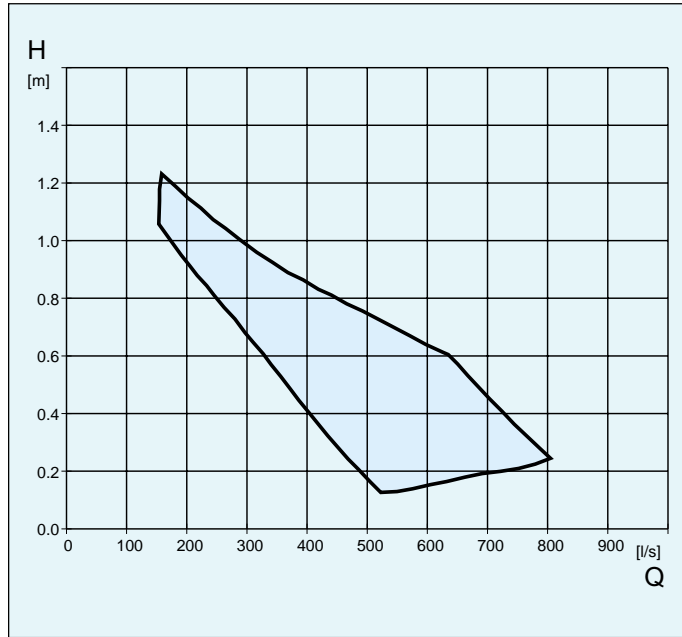

PP 4660

3-phase

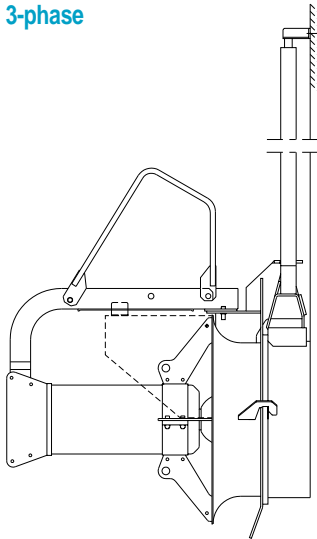

Max. power, input	13.4 kW
Rated power, output	10 kW
Speed	475* r/min
Weight	242 kg

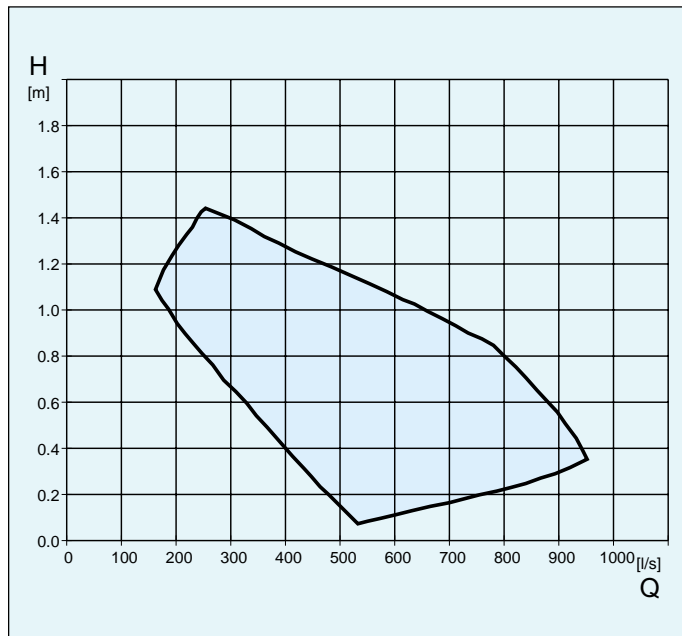

*400V

PP 4670

3-phase

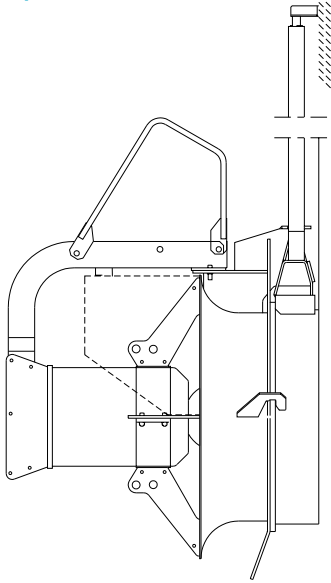

Max. power, input	17.1 kW
Rated power, output	13 kW
Speed	360* r/min
Weight	395 kg

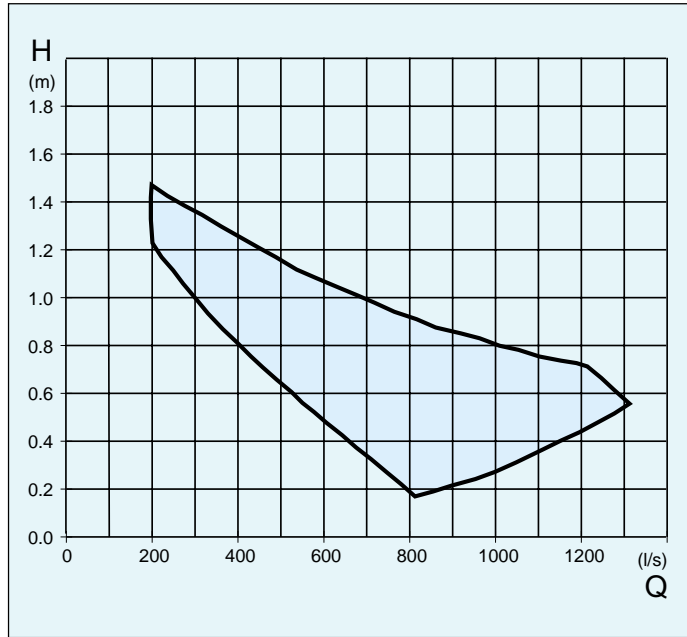

PP 4680

3-phase

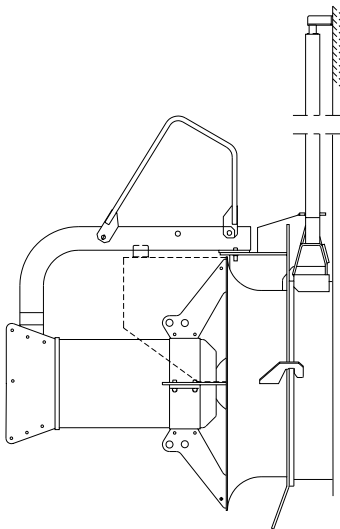

Max. power, input	32 kW
Rated power, output	25 kW
Speed	360* r/min
Weight	516 kg

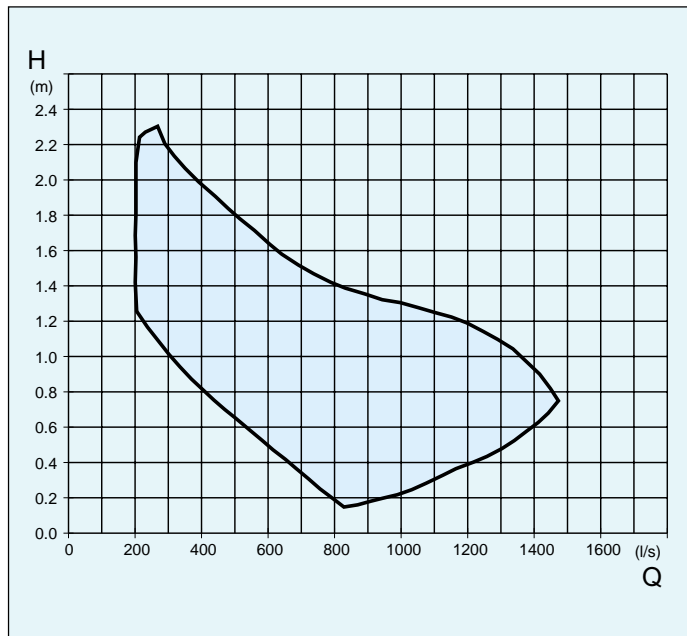

*400V

PROPELLER-PUMPS • 50 Hz

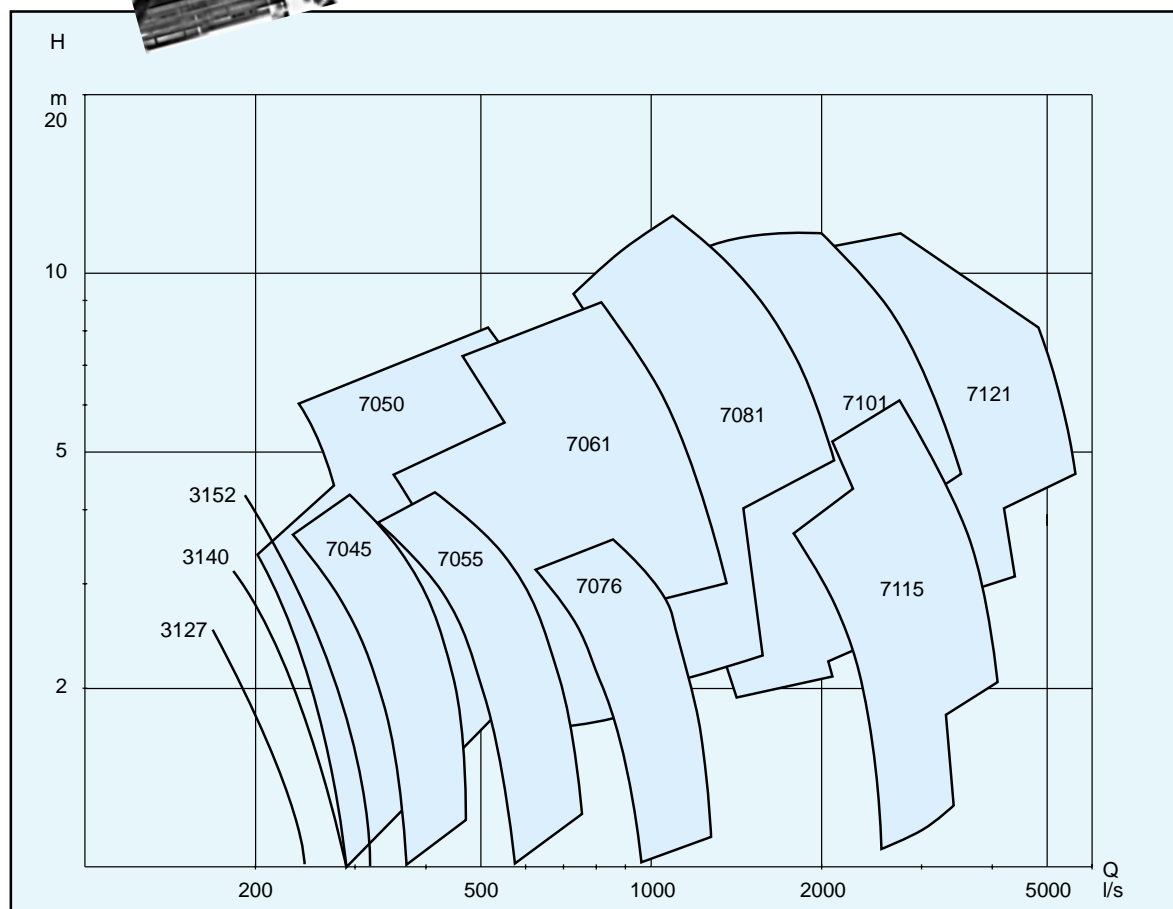
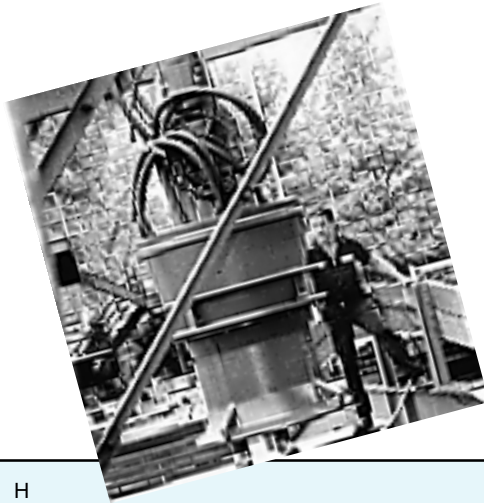

The propeller is dynamically balanced for minimum vibration and maximum life of seals and bearings. Its new, hydrodynamic, conical design affords more efficient pumping. Moreover, the propeller's swept-back blades (for low-clogging performance) are numerically machined to match the pump's specified duty point.

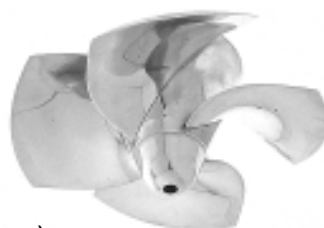

P 3127

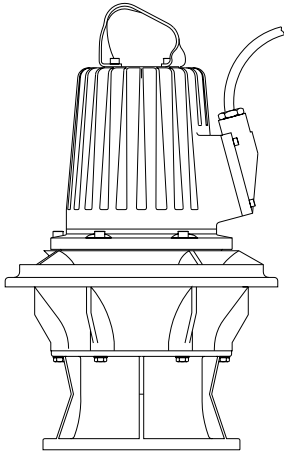

PL

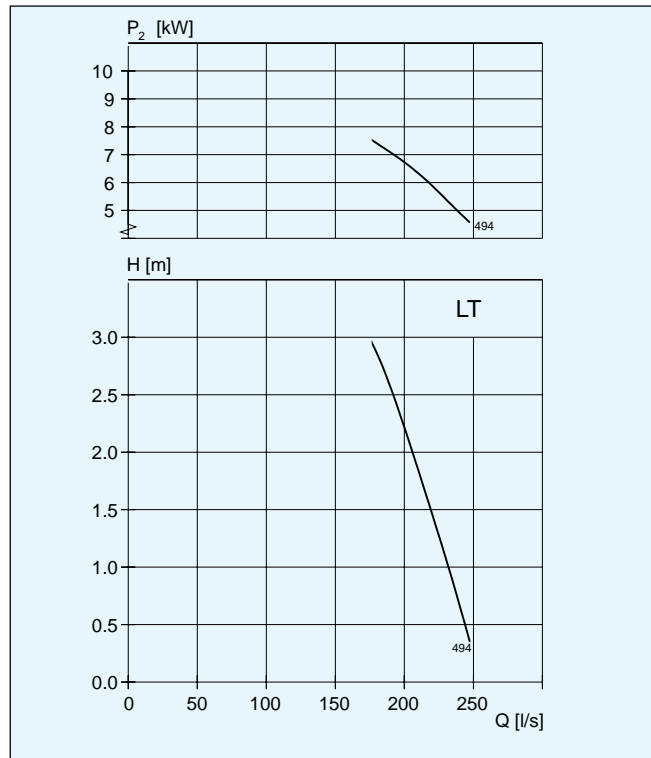

Curve code	Overall diam. mm diff. ring	Motor rating, kW		rpm	Max weight kg
		P_1	P_2		
494	∅490	9.1	7.5	1435	182

P 3140

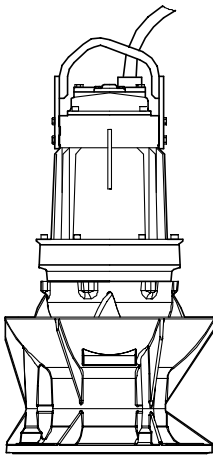

PL

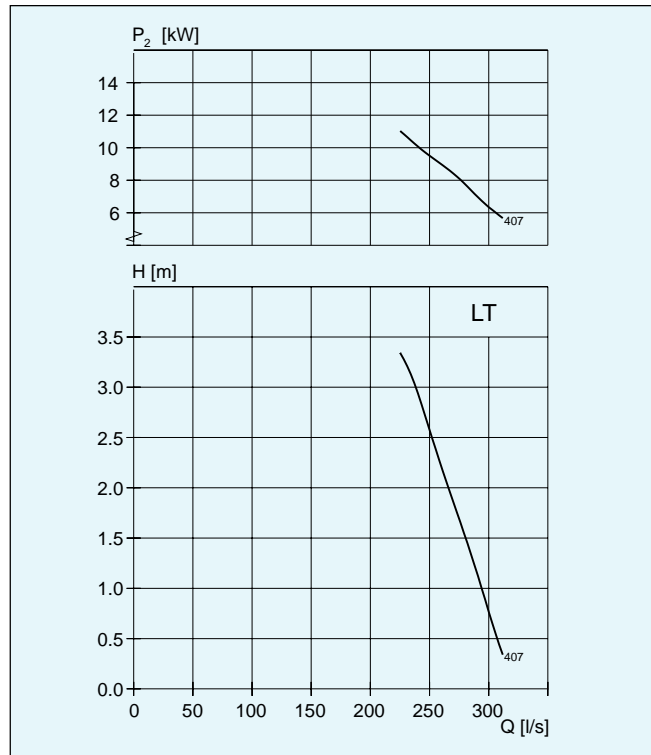

Curve code	Overall diam. mm diff. ring	Motor rating, kW		rpm	Max weight kg
		P_1	P_2		
407	∅575	13.3	11	1440	270

P 3152

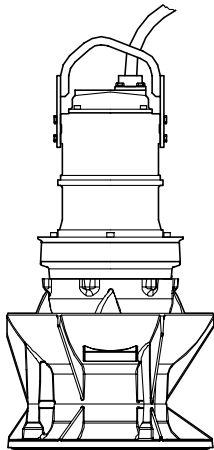

PL

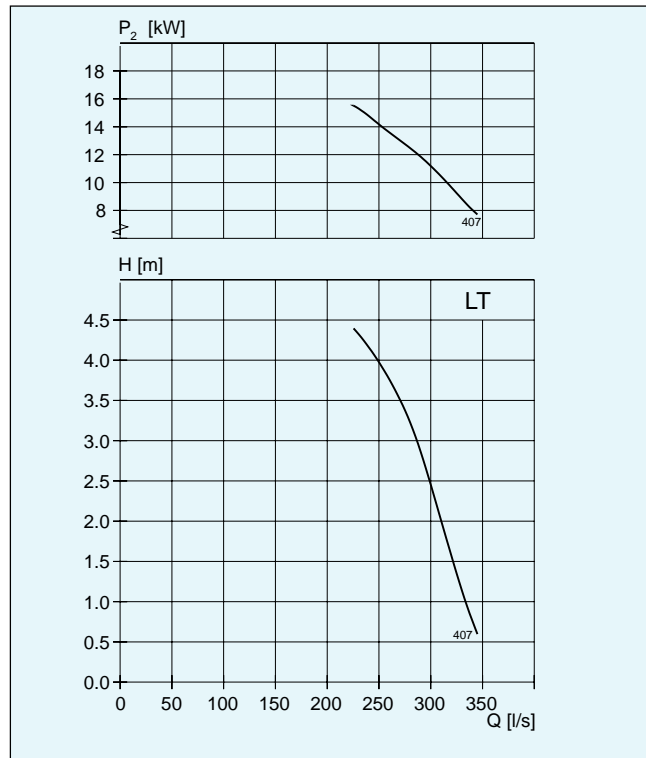

Curve code	Overall diam. mm diff. ring	Motor rating, kW		rpm	Max weight kg
		P_1	P_2		
407	∅ 575	18,4	15,5	1440	273

P 7045

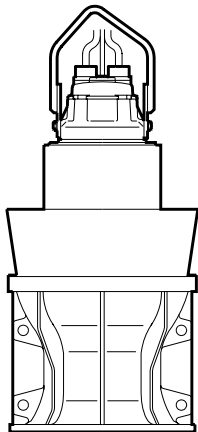

PL

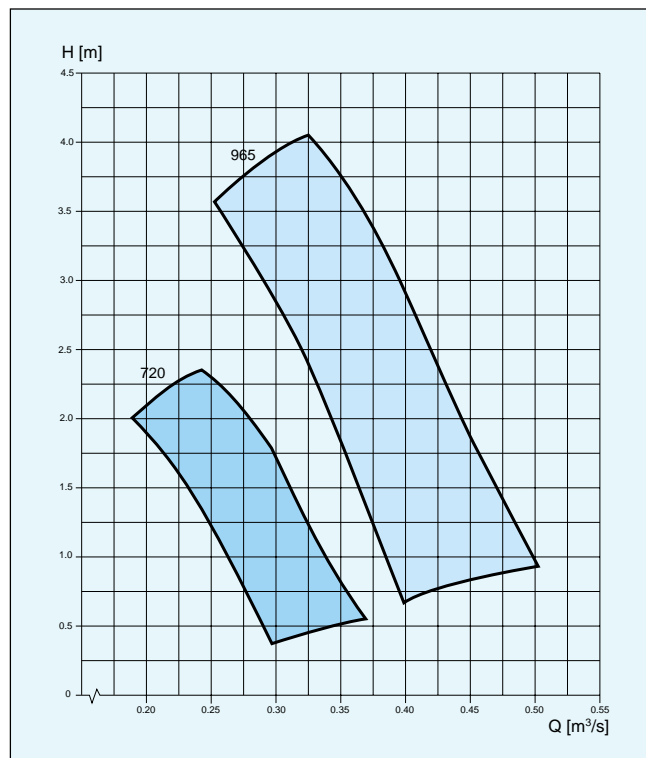

Curve code	Overall diam. mm diff. ring	Motor rating, kW		rpm	Overall height mm	Max weight kg
		P_1	P_2			
965	655	20-26	17-22	965	1425	420
720	655	13,3	11	720	1425	420

P 7050

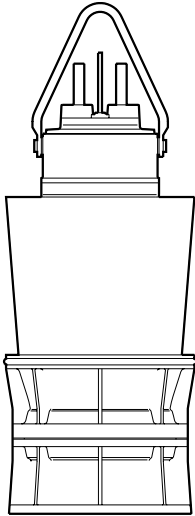

PL

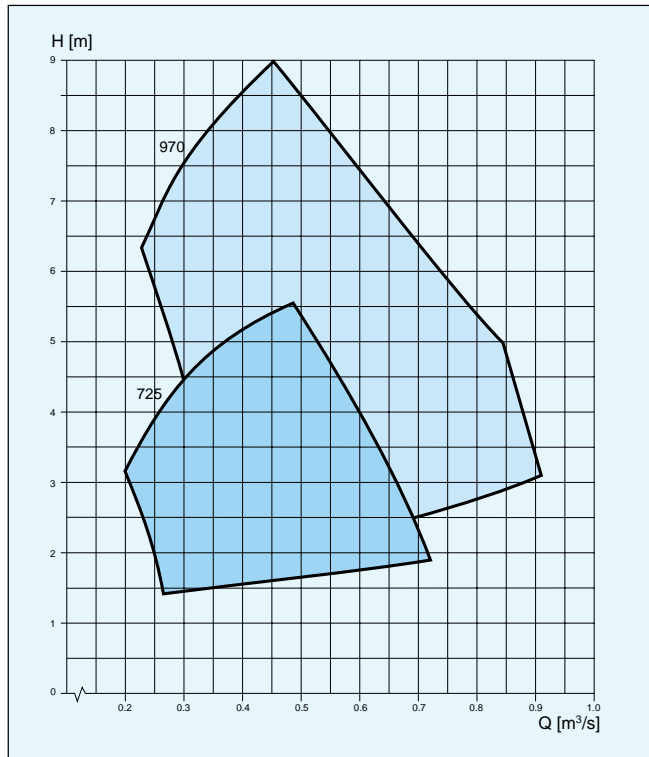

Curve code	Overall diam. mm diff. ring	Motor rating, kW		rpm	Overall height mm	Max weight kg
		P ₁	P ₂			
970	655	52-64	45-55	970	1735	750
725	655	31-42	27-37	725	1735	750

P 7055

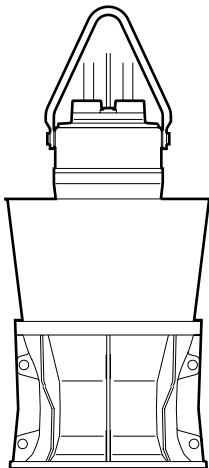

PL

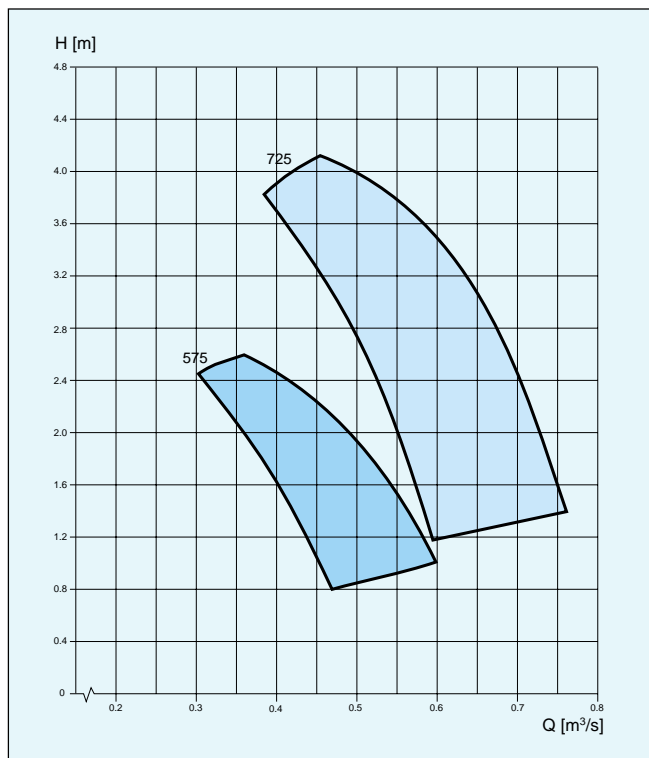

Curve code	Overall diam. mm diff. ring	Motor rating, kW		rpm	Overall height mm	Max weight kg
		P ₁	P ₂			
725	755	20-42	17-37	725	1700	630
575	755	16-20	13-17	575	1700	630

P 7061

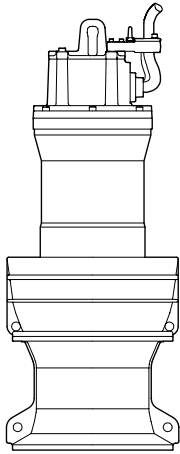

PL

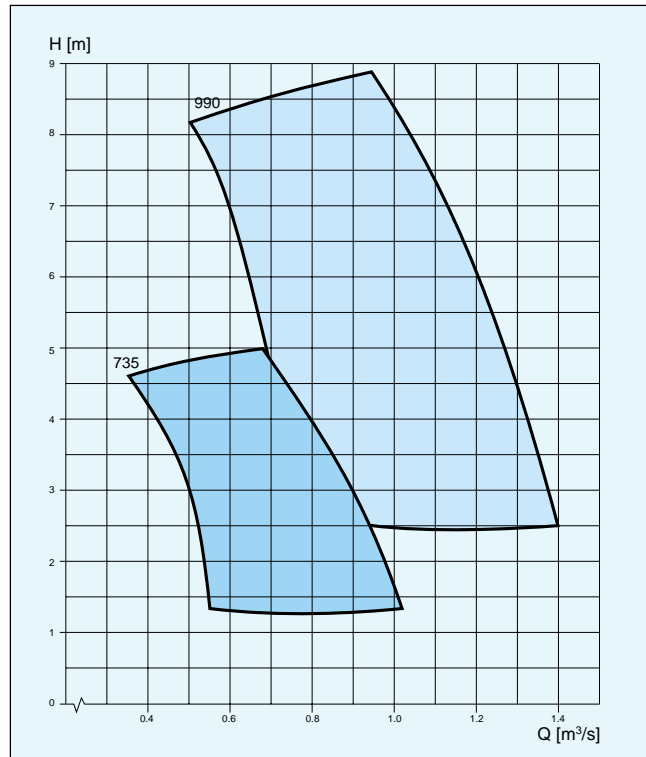

Curve code	Overall diam. mm diff. ring	Motor rating, kW		rpm	Overall height mm	Max weight kg
		P ₁	P ₂			
990	770	64-173	58-160	990	2370	1350
735	770	51-61	46-55	735	2370	1350

P 7076

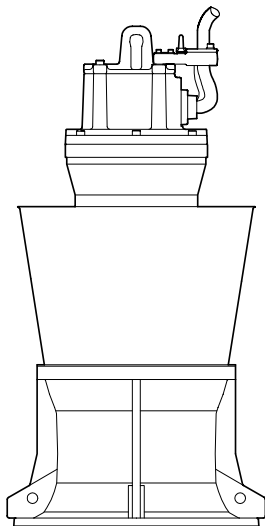

PL



Curve code	Overall diam. mm diff. ring	Motor rating, kW		rpm	Overall height mm	Max weight kg
		P ₁	P ₂			
580	920	43-61	37-55	580	2315	1250

P 7081

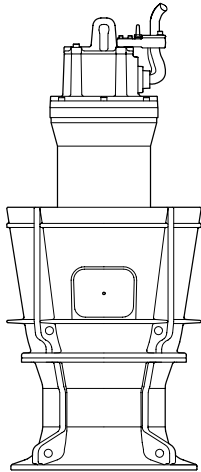

PL

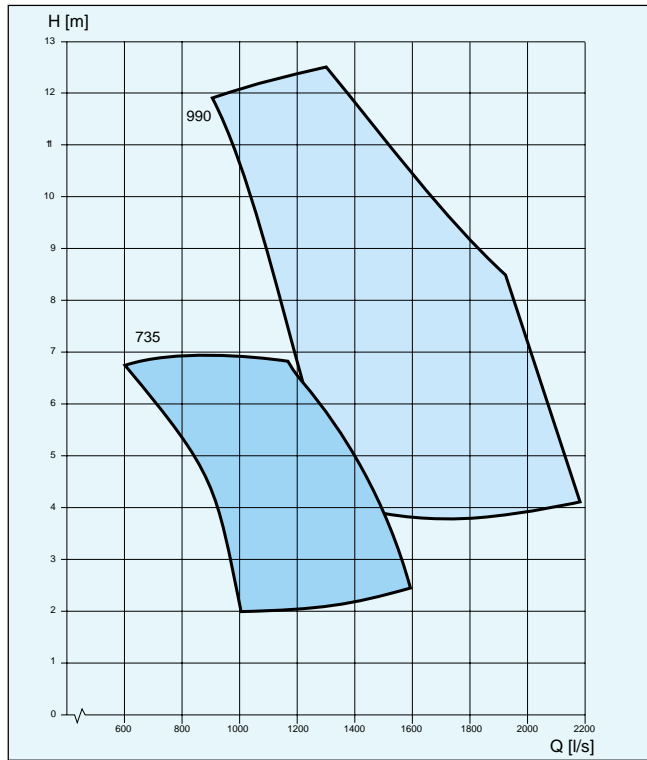

Curve code	Overall diam. mm diff. ring	Motor rating, kW		rpm	Overall height mm	Max weight kg
		P ₁	P ₂			
990	965	173-214	160-200	990	2675	1950
735	965	61-155	55-140	735	2675	1950

P 7101

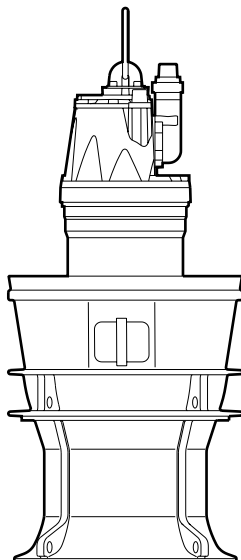

PL

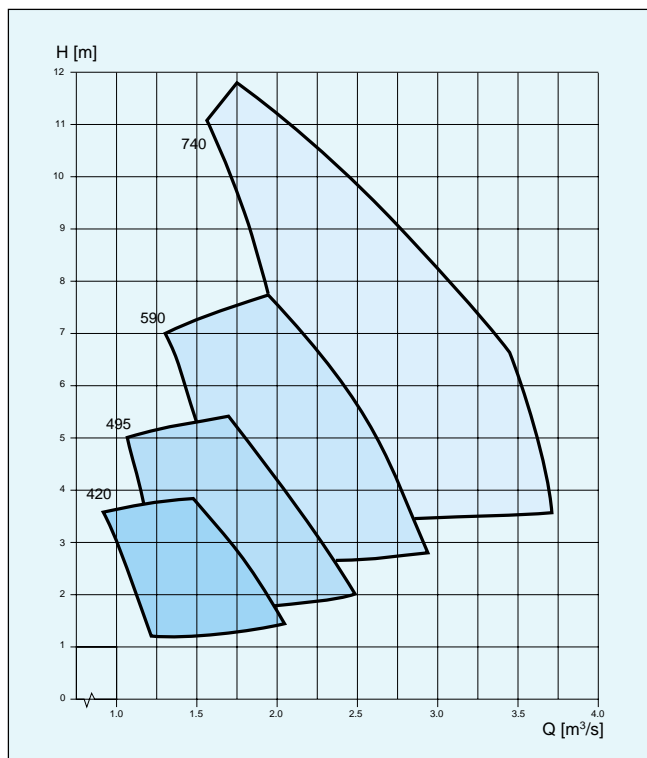

Curve code	Overall diam. mm diff. ring	Motor rating, kW		rpm	Overall height mm	Max weight kg
		P ₁	P ₂			
740	1170	246-320	230-300	740	3050	3300
590	1170	111-247	100-230	590	3050	3300
495	1170	67-174	60-160	495	3050	3300
420	1170	46-99	40-90	420	3050	3300

P 7115

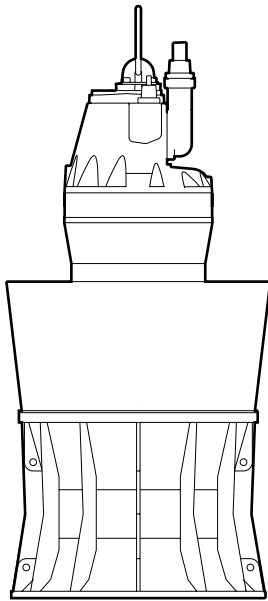

PL

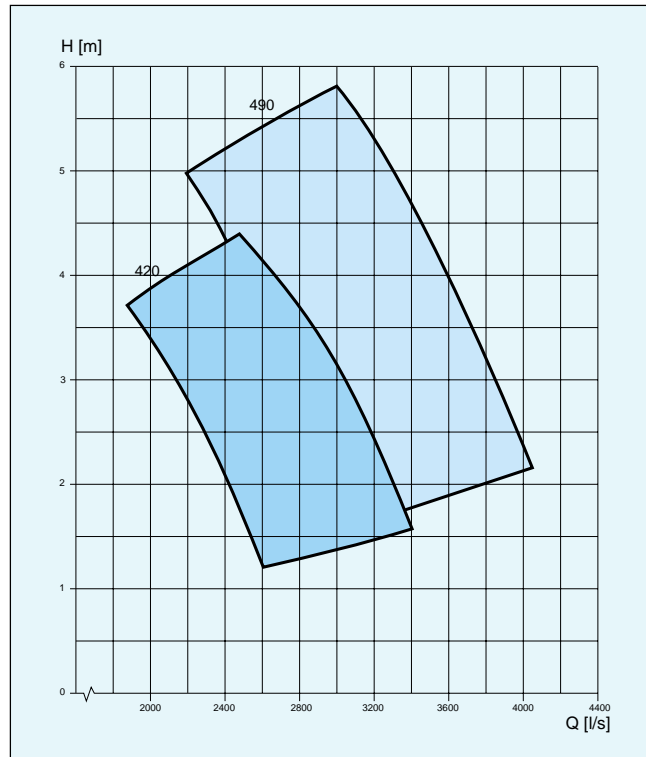

Curve code	Overall diam. mm diff. ring	Motor rating, kW		rpm	Overall height mm	Max weight kg
		P ₁	P ₂			
490	1360	174-241	160-225	490	3530	4500
420	1360	99-167	90-150	490	3530	4500

P 7121

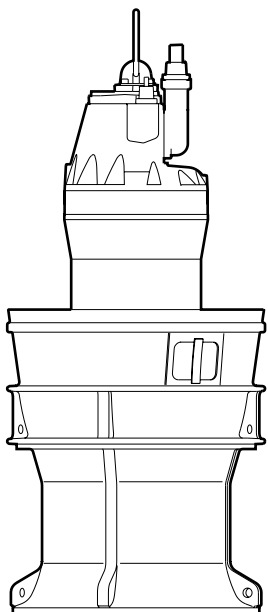

PL

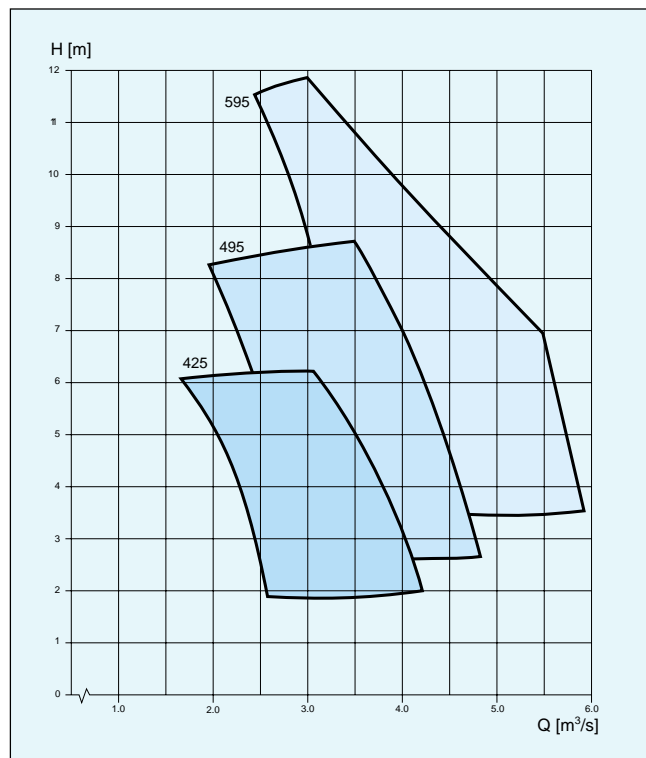

Curve code	Overall diam. mm diff. ring	Motor rating, kW		rpm	Overall height mm	Max weight kg
		P ₁	P ₂			
595	1370	385-484	365-460	595	3410	5200
495	1370	217-435	200-410	495	3410	5200
425	1370	140-267	125-250	425	3410	5200

B-PUMPS • 50 Hz

IN BRONZE AND STAINLESS STEEL

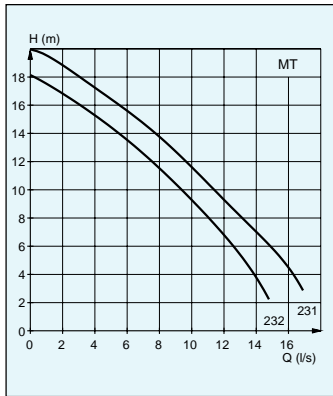

2060
Stainless steel

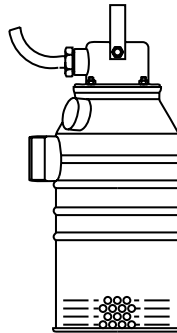

Weight, kg	BS
	32

Impeller code	Outlet dia mm BS vers.	Through-let, mm	Motor rating kW	rpm	Available versions
231	62	8	2.2	2800	BS
232	62	8	2.2	2800	BS

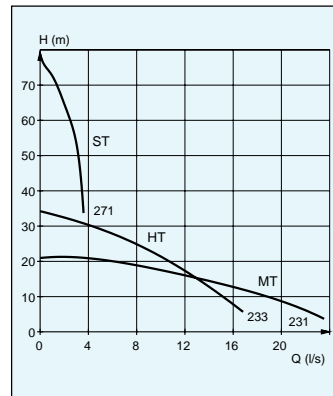

2075
Bronze

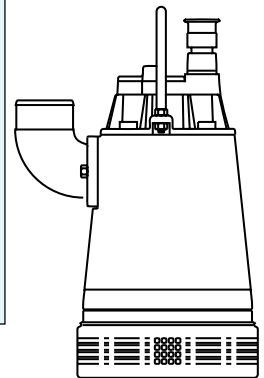

Weight, kg	BS
	85

Impeller code	Outlet dia mm BS vers.	Through-let, mm	Motor rating kW	rpm	Available versions
233	75	8	3.7	2800	BS
231	100	8	3.7	2800	BS

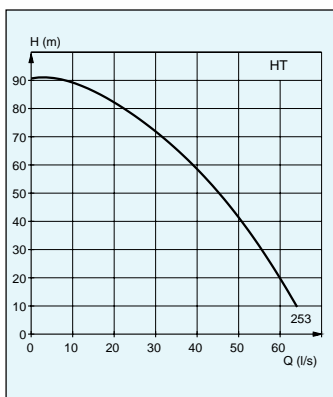

2201
Bronze

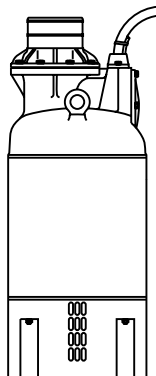

Weight, kg	BS
	460

Impeller code	Outlet dia mm BS vers.	Through-let, mm	Motor rating kW	rpm	Available versions
253	100	10	37	2920	BS

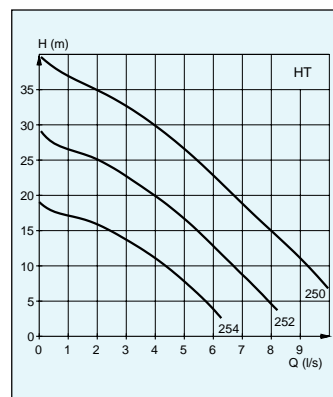

3085
Stainless steel

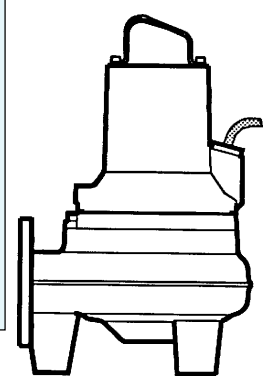

Weight, kg	BP	BS
	58	58

Impeller code	No. of channels	Outlet dia mm BP vers.	Through-let, mm	Motor rating kW P ₁ P ₂	rpm	Available versions
250	3	50	10	3.0 2.4	2830	BP/BS
252	3	50	10	3.0 2.4	2830	BP/BS
254	3	50	10	3.0 2.4	2830	BP/BS

C-PUMPS • 50 Hz IN STAINLESS STEEL

C 3060

Stainless steel

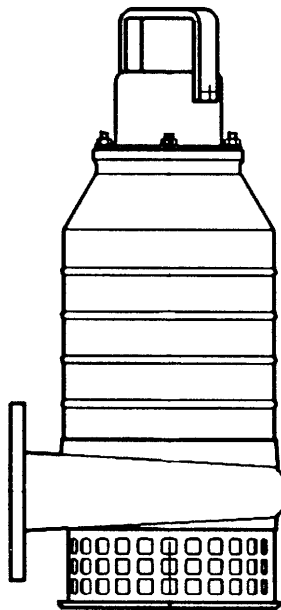

	CP	CT	CS
Weight, kg (with cooling jacket)	41	45	41
	41	45	41

CP/CT/CS

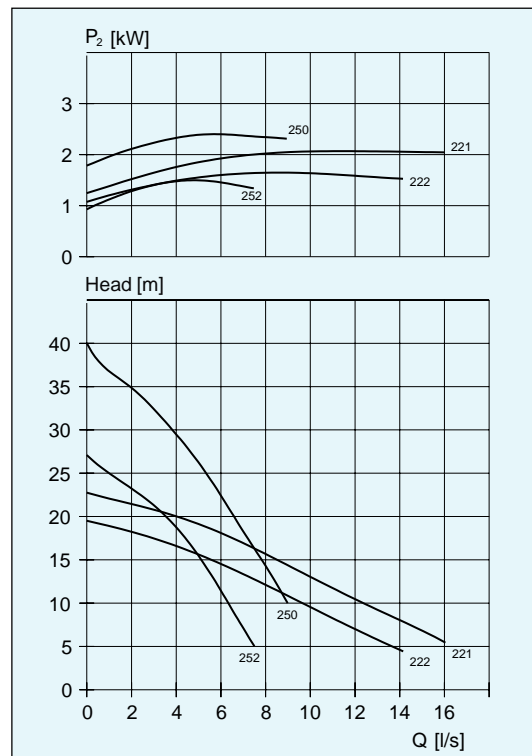

Impeller code	No. of vanes	Outlet dia mm CP vers.	Through-let, mm	Motor rating kW		rpm	Available versions
				P ₁	P ₂		
221	2	80	15 x 15	3.3	2.4	2800	CP/CT/CS
222	2	80	15 x 15	3.3	2.4	2800	CP/CT/CS
250	2	80	15 x 15	3.3	2.4	2800	CP/CS
252	2	80	15 x 15	3.3	2.4	2800	CP/CS

C 3085

Stainless steel

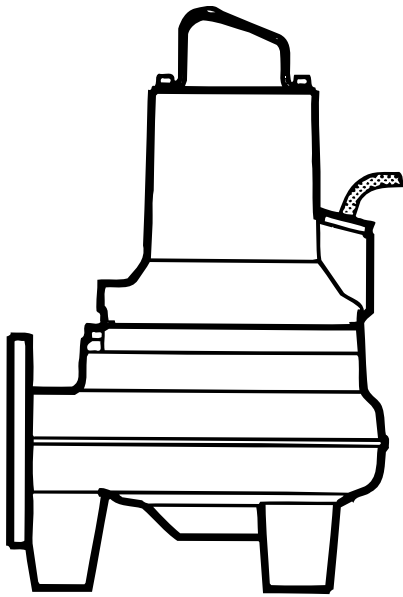

Weight, kg	CP	CS
MT	72	72

*NEVACLOG

CP/CS

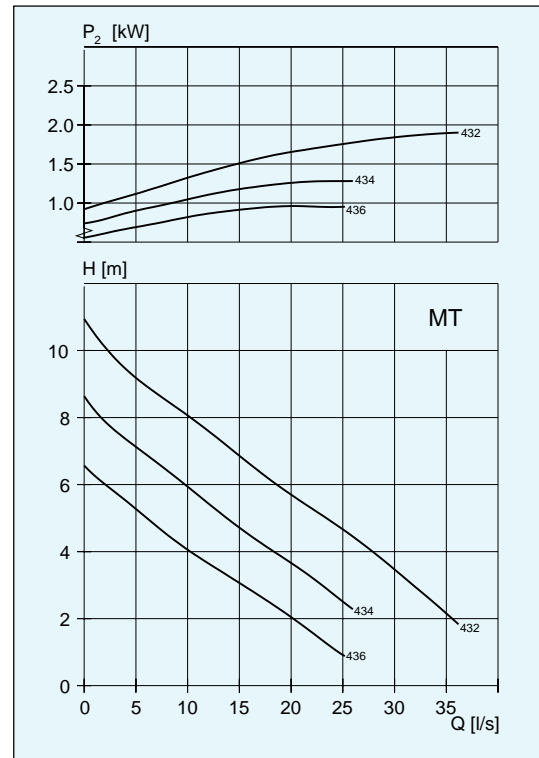

Impeller code	No. of channels	Outlet dia mm CP vers.	Through-let, mm	Motor rating kW		rpm	Available versions
				P_1	P_2		
432*	1	80	∅ 73	27	20	1385	CP/CS
434*	1	80	∅ 73	27	20	1385	CP/CS
436*	1	80	∅ 73	27	20	1385	CP/CS

C 3126

Stainless steel

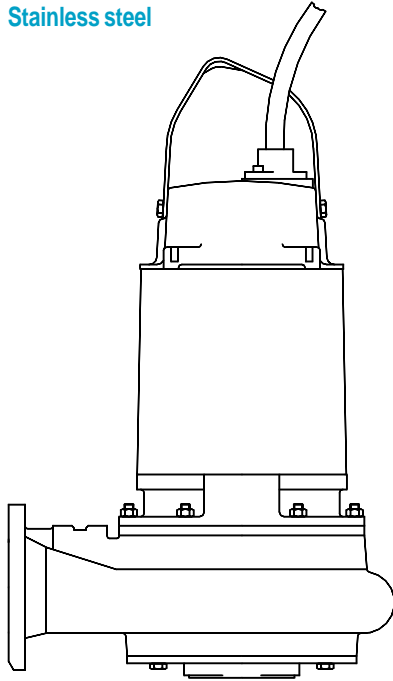

Weight, kg	CP	CS	CT	CZ
HT	156	162	185	255
MT	164	168	215	263

CP/CS/CT/CZ

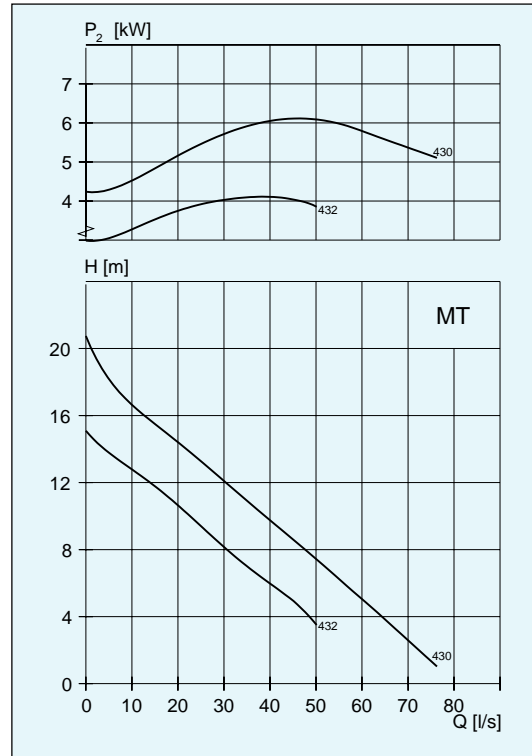

Impeller code	No. of channels	Outlet dia mm CP vers.	Through-let, mm	Motor rating kW		rpm	Available versions
				P_1	P_2		
W430	1	100	100x110	8.0	6.7	1440	CP/CS/CT/CZ
W432	1	100	87x100	8.0	6.7	1440	CP/CS/CT/CZ
W432	1	100	87x100	6.5	5.3	1435	CP/CS/CT/CZ

CP/CS/CT/CZ

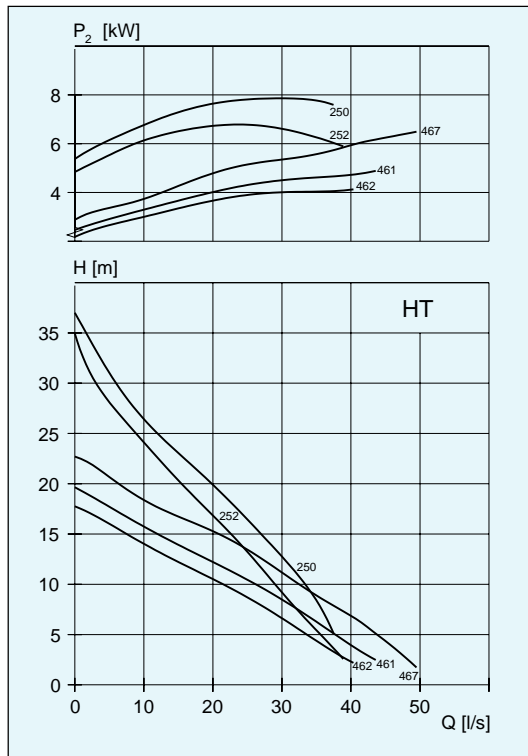

Impeller code	No. of channels	Outlet dia mm CP vers.	Through-let, mm	Motor rating kW		rpm	Available versions
				P_1	P_2		
W250	1	80	∅ 58	9.5	8.0	2890	CP/CS/CT/CZ
W252	1	80	∅ 58	9.5	8.0	2890	CP/CS/CT/CZ
W461	1	100	∅ 76	8.0	6.7	1440	CP/CS/CT/CZ
W461	1	100	∅ 76	6.5	5.3	1435	CP/CS/CT/CZ
W462	1	100	∅ 76	8.0	6.7	1440	CP/CS/CT/CZ
W462	1	100	∅ 76	6.5	5.3	1435	CP/CS/CT/CZ
W467	1	100	∅ 76	8.0	6.7	1440	CP/CS/CT/CZ

C 3201

Stainless steel

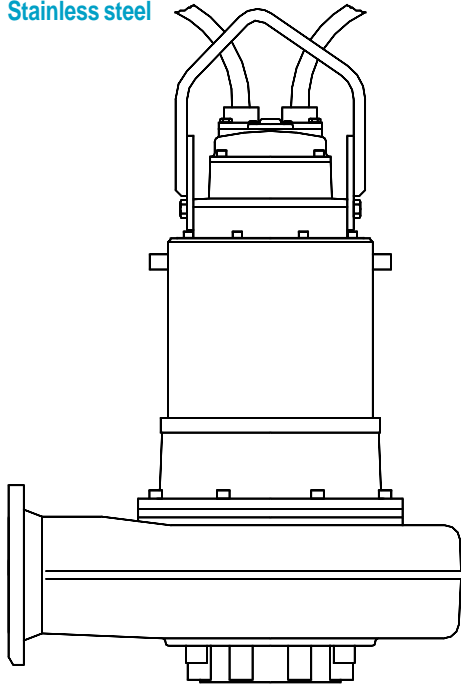

Weight, kg	CP	CS	CT	CZ
HT	560	510	675	675
MT	550	500	580	580

CP/CS/CT/CZ

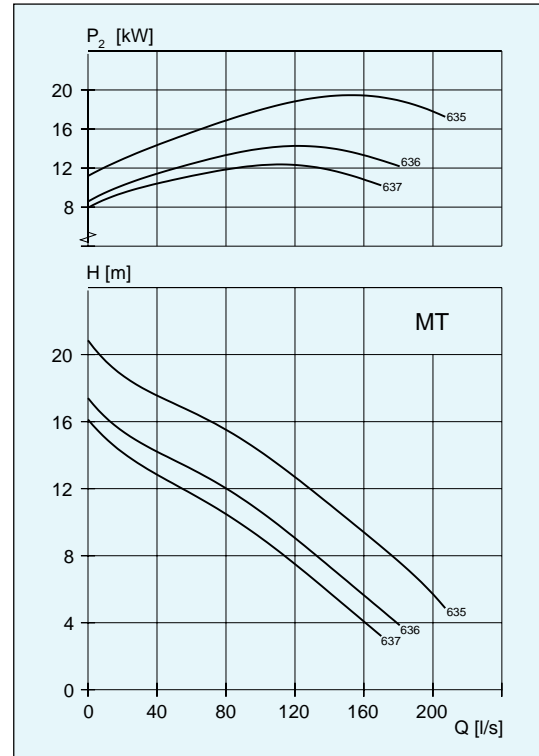

Impeller code	No. of channels	Outlet dia mm CP vers.	Through-let, mm	Motor rating kW		rpm	Available versions
				P ₁	P ₂		
W635	2	250	102 x 84	25	22	970	CP/CS/CT/CZ
W636	2	250	102 x 84	25	22	970	CP/CS/CT/CZ
W637	2	250	102 x 84	25	22	970	CP/CS/CT/CZ

CP/CS/CT/CZ

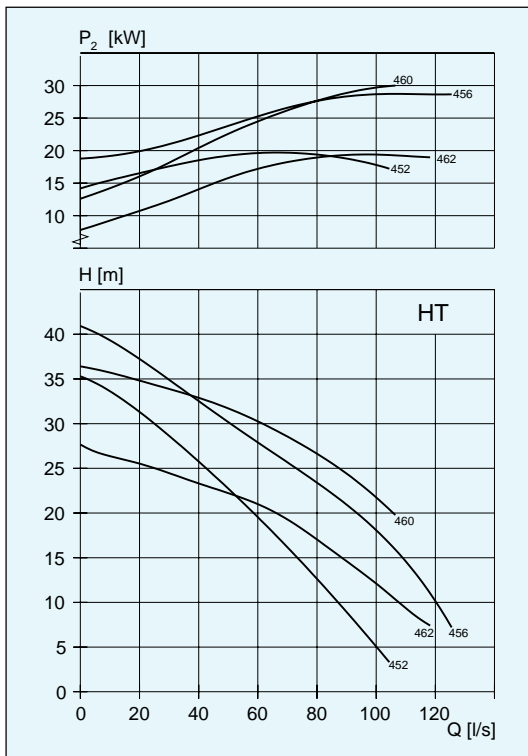

Impeller code	No. of channels	Outlet dia mm CP vers.	Through-let, mm	Motor rating kW		rpm	Available versions
				P ₁	P ₂		
W452	1	200	77 x 77	34	30	1455	CP/CS/CT/CZ
452	1	200	77 x 77	25	22	1460	CP/CS/CT/CZ
456	1	200	∅ 100	34	30	1455	CP/CS/CT/CZ
460	3	200	59 x 65	34	30	1455	CP/CS/CT/CZ
W462	3	200	59 x 65	34	30	1455	CP/CS/CT/CZ
462	3	200	59 x 65	25	22	1460	CP/CS/CT/CZ

C 3300

Stainless steel

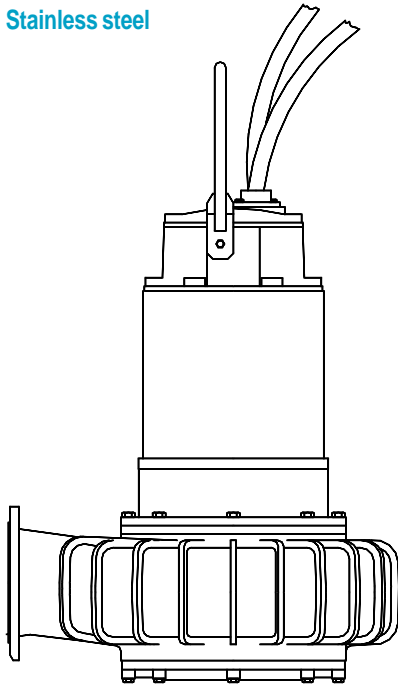

Weight, kg	CP	CS	CT	CZ
HT	950	1003	1043	1043
MT	1150	1176	1236	1236

CP/CS/CT/CZ

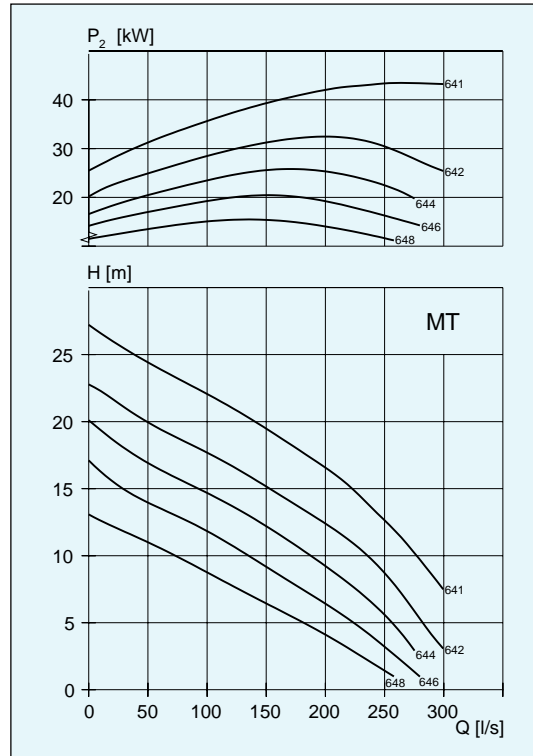

Impeller code	No. of channels	Outlet dia mm CP vers.	Through-let, mm	Motor rating kW		rpm	Available versions
				P ₁	P ₂		
641	2	300	100x100	50	44	975	CP/CS/CT/CZ
642	2	300	100x100	50	44	975	CP/CS/CT/CZ
644	2	300	100x100	50	44	975	CP/CS/CT/CZ
646	2	300	100x100	50	44	975	CP/CS/CT/CZ
648	2	300	100x100	50	44	975	CP/CS/CT/CZ

CP/CS/CT/CZ

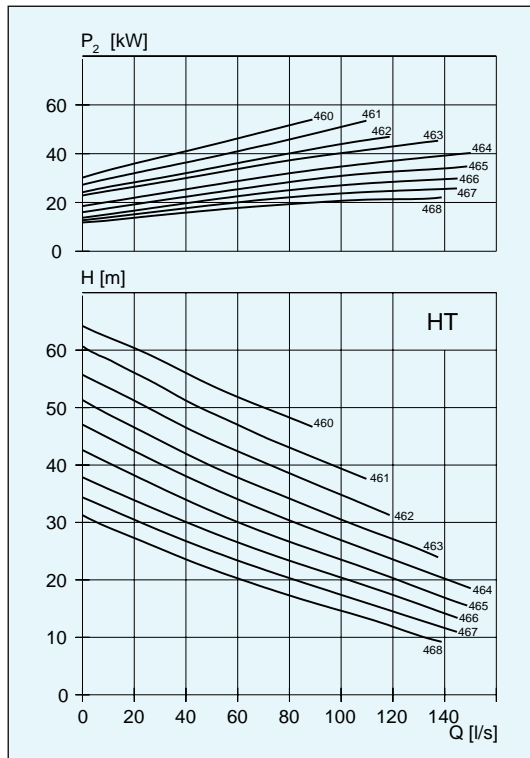

Impeller code	No. of channels	Outlet dia mm CP vers.	Through-let, mm	Motor rating kW		rpm	Available versions
				P ₁	P ₂		
460	2	200	76 x 76	59	54	1475	CP/CS/CT/CZ
460	2	200	76 x 76	45	40	1475	CP/CS/CT/CZ
461	2	200	76 x 76	59	54	1475	CP/CS/CT/CZ
462	2	200	76 x 76	59	54	1475	CP/CS/CT/CZ
463	2	200	76 x 76	59	54	1475	CP/CS/CT/CZ
464	2	200	76 x 76	59	54	1475	CP/CS/CT/CZ
465	2	200	76 x 76	59	54	1475	CP/CS/CT/CZ
466	2	200	76 x 76	59	54	1475	CP/CS/CT/CZ
466	2	200	76 x 76	45	40	1475	CP/CS/CT/CZ
467	2	200	76 x 76	59	54	1475	CP/CS/CT/CZ
467	2	200	76 x 76	45	40	1475	CP/CS/CT/CZ
468	2	200	76 x 76	59	54	1475	CP/CS/CT/CZ

D-PUMPS • 50 Hz

IN BRONZE AND STAINLESS STEEL

D 3060

Stainless steel

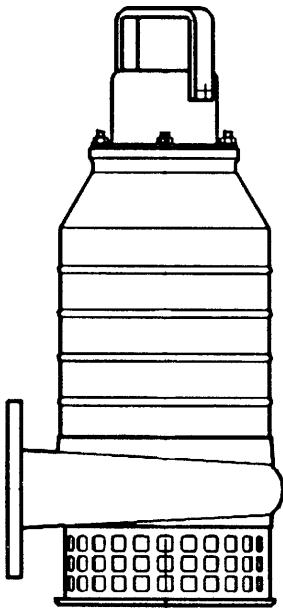

Pump type	DP	DS	DT
Weight, kg	41	41	45

DP/DT/DS

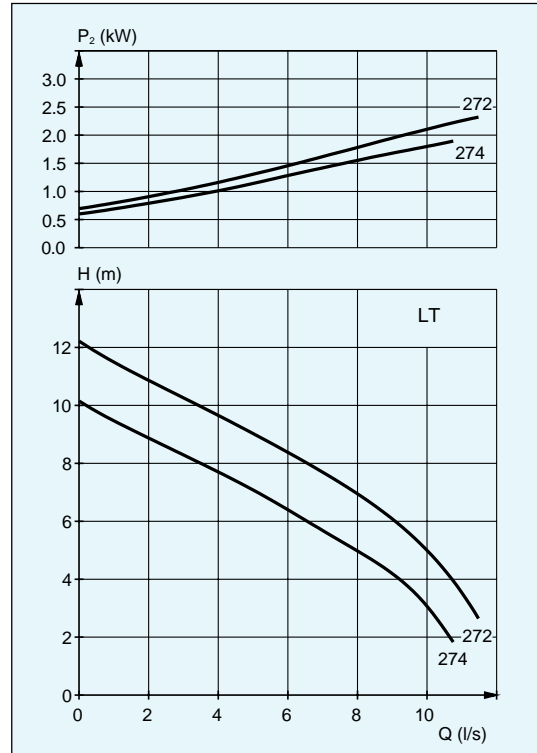

Impeller code	Outlet dia mm, DP vers.	Through-let, mm	Motor rating kW		rpm	Available versions
			P ₁	P ₂		
272	75	15 x 15	3.3	2.4	2800	DP/DT/DS
274	75	15 x 15	3.3	2.4	2800	DP/DT/DS

D 3080

Bronze

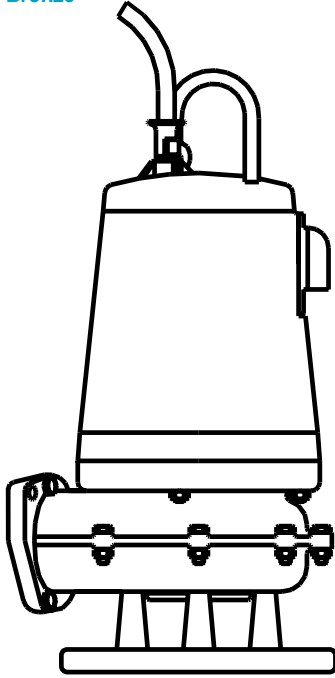

	DS
Weight, kg	105

DS

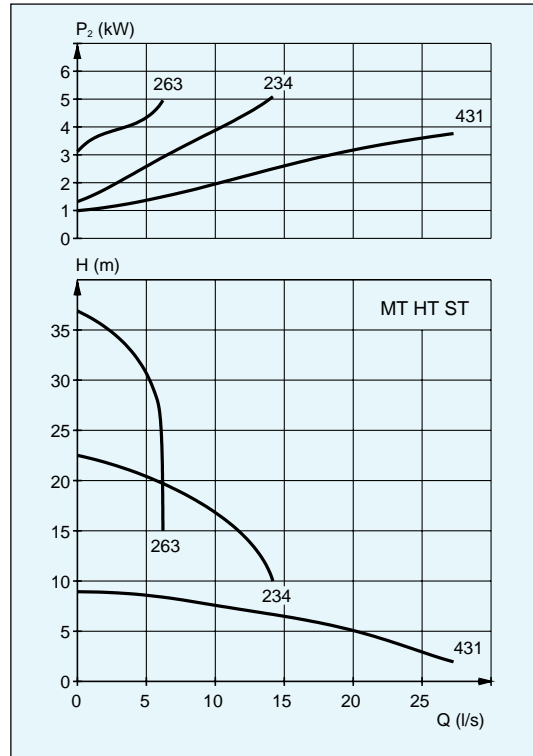

Impeller code	Outlet dia mm, DP vers.	Through-let, mm	Motor rating kW		rpm	Available versions
			P ₁	P ₂		
263	75	25	7.3	5.5	2800	DS
234	75	40	7.3	5.5	2800	DS
431	100	75	5.0	4.0	1400	DS

D 3085

Stainless steel

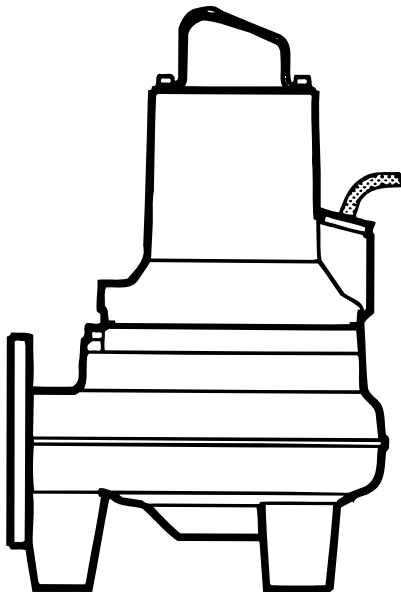

	DP	DS
Weight, kg	68	68

DP/DS

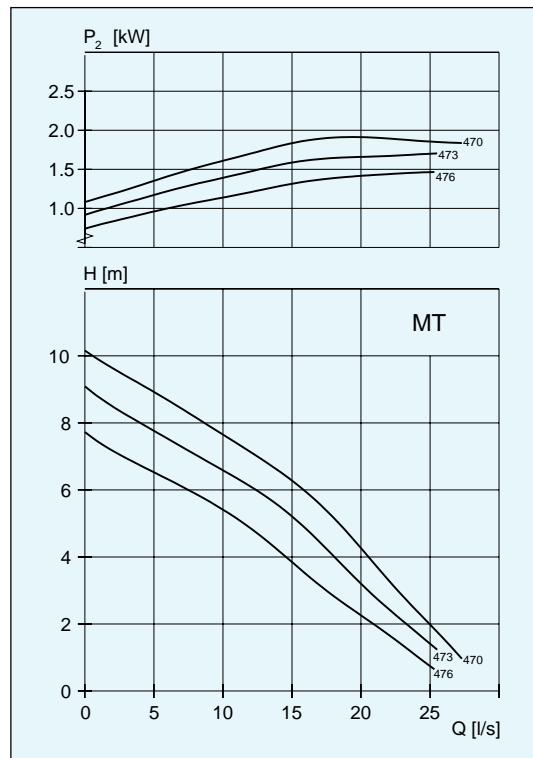

Impeller code	Outlet dia mm, DP vers.	Through-let, mm	Motor rating kW		rpm	Available versions
			P ₁	P ₂		
470	80	65	2.7	2.0	1395	DP/DS
473	80	65	2.7	2.0	1395	DP/DS
476	80	65	2.7	2.0	1395	DP/DS

D 3126

Stainless steel

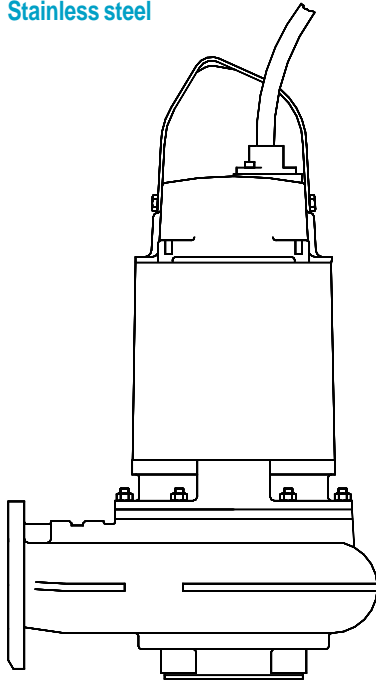

Weight, kg	DP	DS	DT	DZ
HT	154	161	-	-
MT	165	165	214	214

DP/DS/DT/DZ

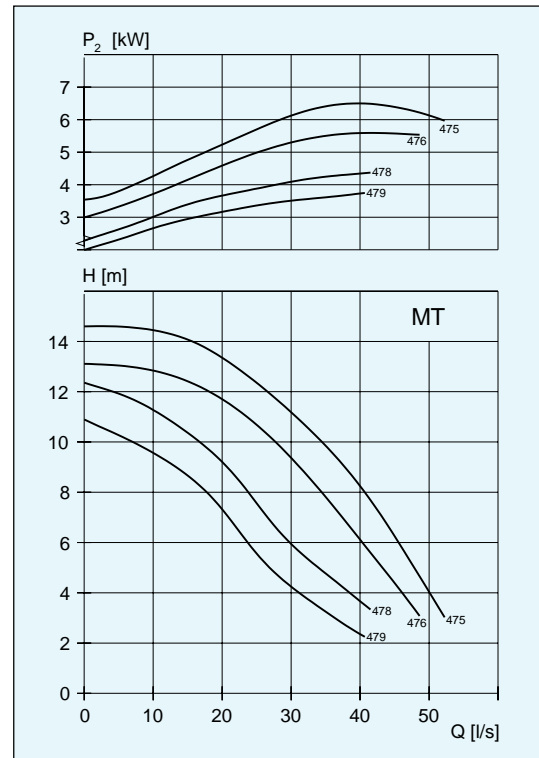

Impeller code	Outlet dia mm, DP vers.	Through-let, mm	Motor rating kW		rpm	Available versions
			P ₁	P ₂		
W475	100	52	8.0	6.7	1440	DP/DS/DT/DZ
W476	100	52	8.0	6.7	1440	DP/DS/DT/DZ
W478	100	52	8.0	6.7	1440	DP/DS/DT/DZ
W478	100	52	6.5	5.3	1435	DP/DS/DT/DZ
W479	100	52	8.0	6.7	1440	DP/DS/DT/DZ
W479	100	52	6.5	5.3	1435	DP/DS/DT/DZ

DP/DS

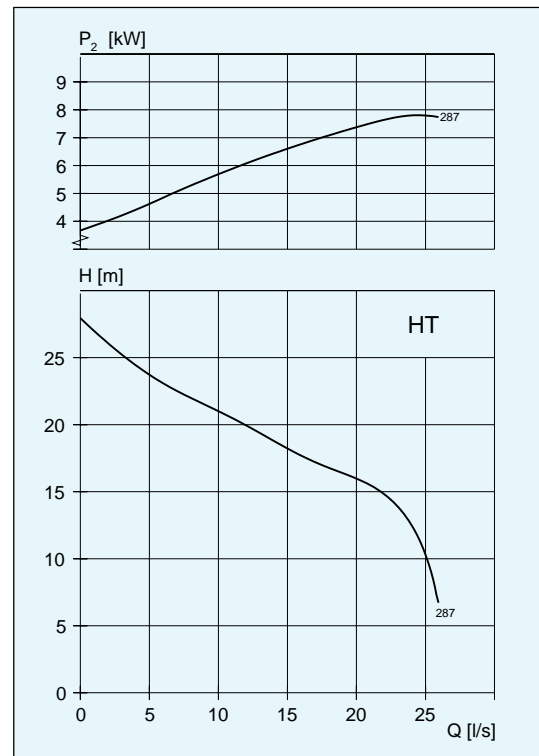

Impeller code	Outlet dia mm, DP vers.	Through-let, mm	Motor rating kW		rpm	Available versions
			P ₁	P ₂		
W287	75	50	9.5	8.0	2890	DP/DS

EXPLOSION PROOF PUMPS AND MIXERS

Many of the Flygt pumps are available in Explosion-Proof execution and various approvals apply. Below is given the classification of the different approvals in accordance with the European norms and the explanation of the letter coding.

E EXd e IIB T4* II G2
E EXd e IIB T3* II G2
E EXd e I* I M2

E = European norm EN 50014

EXd = Explosionproof encapsulation permitted in Zone 1 and 2. EN 50018.

e = Increased safety. EN 50019.

I = Gas group (Methane), cool mines

IIB = Gas group (Ethylene), industry

T4 = Temp. class. Max. surf.temp. = 135° C.

T3 = Temp. class. Max. surf. temp. = 200° C.

Approval No. The thermocontacts in the equipment must be connected.

II G2 and I M2 = Equipment groups and categories acc. to EC-Directive 94/9/EC.

Classification of hazardous areas

Hazardous locations are those in which flammable materials are likely to be present or introduced in concentrations, which can be ignited through normal or abnormal equipment operation. Equipment must generally be approved for these locations. Hazardous areas are classified into zones according to the IEC 79-10. Most of the European countries have standards or norms which conform with this recommendation.

Due to the temporary and local probability of the presence of an explosive atmosphere, the hazardous areas are divided into zones as follows:

- Zone 0:** Area in which an explosive atmosphere is continuously present for long periods.
- Zone 1:** Areas in which an explosive atmosphere is likely to occur in normal operation.
- Zone 2:** Areas in which an explosive atmosphere is not likely to occur in normal operation and, if it occurs, it will only exist for a short time.

Flygt guarantees the pumps to be in compliance with the above mentioned approvals when being delivered.

It is the responsibility of the owner to make sure that the equipment is used in accordance with the approval and in applications for which it is intended. Special attention should be paid to the connection of safety devices such as thermocontacts and the earthing systems.

All modification and repair work must be performed in accordance with the original approval and by using only genuine Flygt parts.

The degree of protection for all Flygt designed and constructed submersible equipment is IP68, 20m.

The following pump-types and mixers are available in EX-proof execution:		
3000-pumps	2000-pumps	Mixers
3057	2075	4352
3067	2125	4400
3068	2135	4410
3085	2201	4430
3102	2400	4610
3127	3067	4620
3140	3080	4630
3152		4640
3153		4650
3170		4660
3171		4670
3201		4680
3300		
3231		
3306		
3312		
3351		
3356		
3400		
3501		
3531		
3602		
3800		

* Please refer to the Care and Maintenance Manual for more detailed information.

DIMENSIONS

All drawings are available as Acrobat documents (.pdf) and AutoCad drawings (.dwg).

Please contact your ITT Flygt representative for more information.

All dimensions are in mm.

