

SITRANS F M MAG 8000
Precise Metering with battery
powered water meters

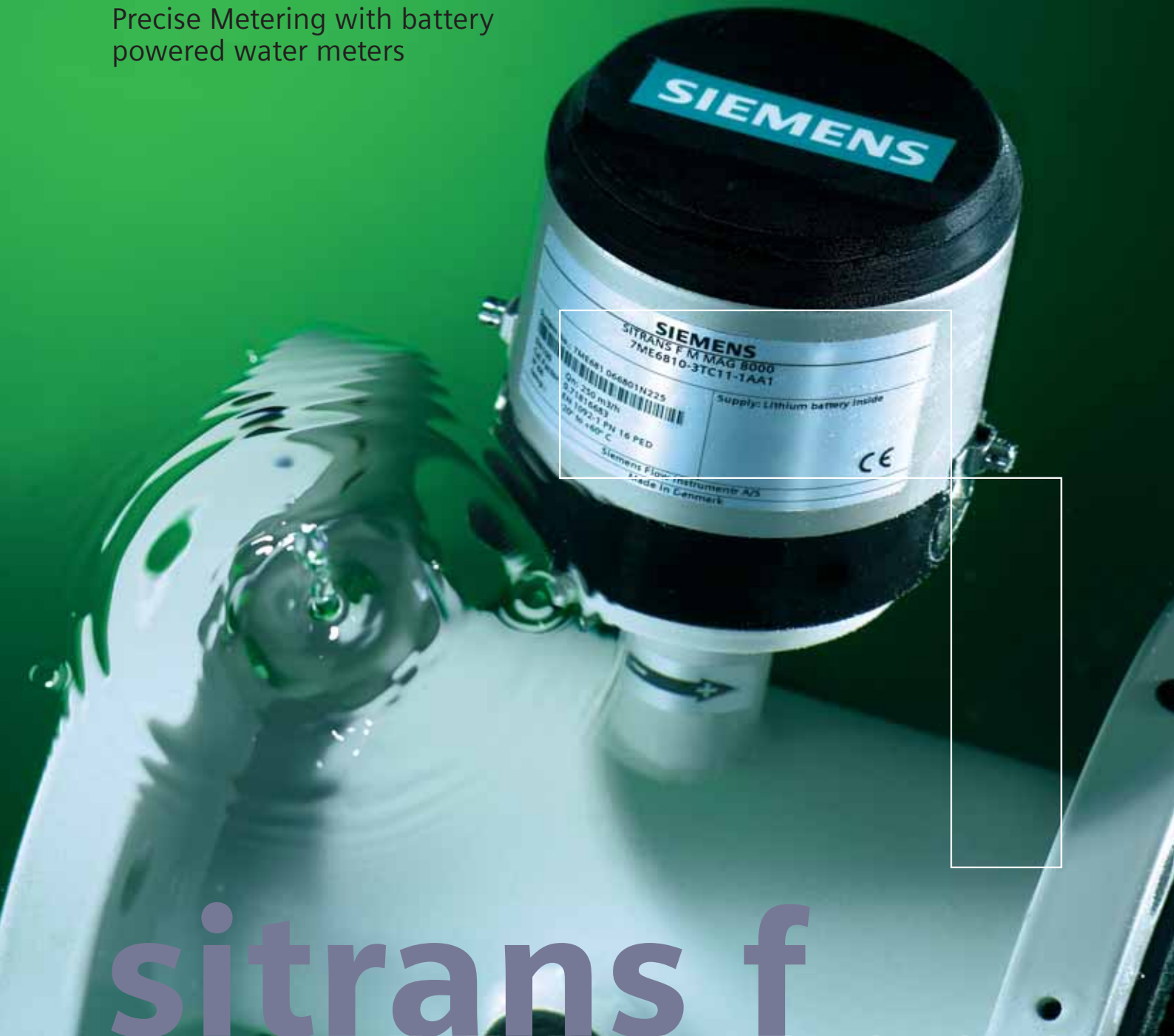

sitrans f MAG 8000



SIEMENS

Compact and remote installation made simple

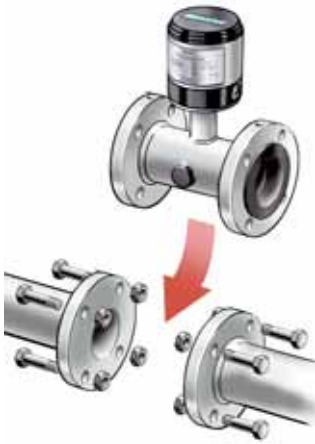

Designed for the water industry, the SITRANS F M MAG 8000 program is a battery powered solution that makes it easier than ever to install a reliable water meter virtually anywhere, without sacrificing accuracy or performance.

- **No mains power is needed!**
- **Simply bolt in place before operation**
- **Remote transmitter solution with factory mounted sensor cables and connectors**
- **Underground installation – sensor can be buried**
- **IP68/NEMA 6P enclosure and cable withstand constant flooding**
- **Flow simulation to ensure correct information chain**
- **Configuration via standard IrDA interface or communication channel**
- **Built-in earthing electrodes**

Easy to install

- *Simply bolt into place before operation*
- *Minimized inlet and outlet requirements*



Flexible power supply

- *Replaceable internal battery pack*
- *External battery pack with waterproof connectors (IP68/NEMA 6P)*
- *Internal mains power supply, 12-24 V AC/DC and 115-230 V AC with battery back-up*



There are no electronics in the remote sensor that can be damaged during installation or operation.

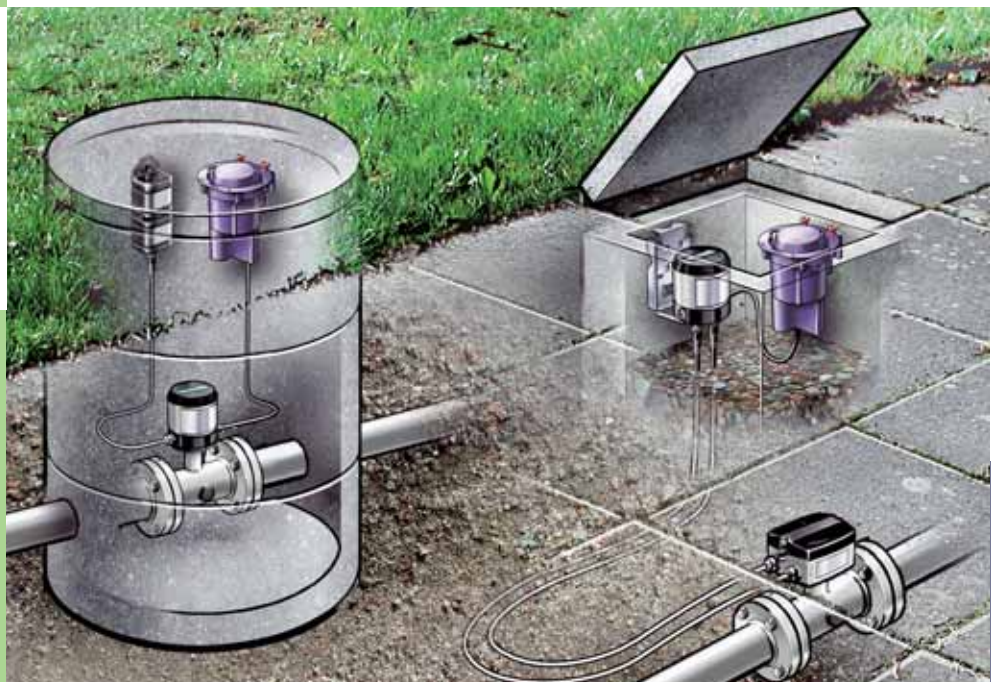

Long lasting accurate performance with 6 years of battery operation

The MAG 8000 program is designed to assure best-in-class performance for leakage detection and accurate billing. It is seriously low maintenance, delivering long-term performance with minimal cost of ownership.

Superior measurement

- High accuracy down to 0.2% of rate and independent of selected power supply
- OIML R49 pattern approval for class I and class II
- Bi-directional measurement with 0.1% high repeatability in both directions
- Internal sensor design optimized for low flow detection
- Documentation of operation conditions with on-board meter self check and diagnostics of application conditions

Long life for low cost of ownership

- 6 years non-stop operation with internal battery pack in typical revenue applications
- No moving parts means less wear and tear
- Robust construction built to resist environmental influences
- Call up function via pulse output to reduce site visits

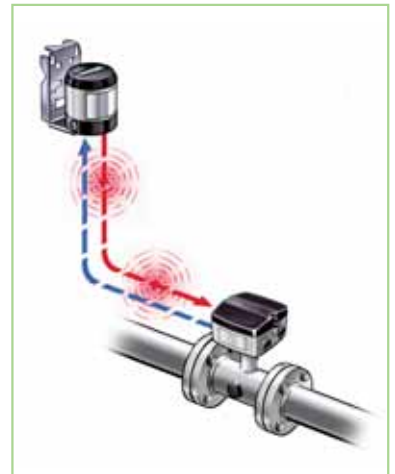

Insulation test

Built-in "cross-talk" test checks the entire signal chain of the system ensuring that the sensor flow signal is unaffected by external noise.



Low-flow detection

Siemens coned flow tube design improves low-flow performance with minimal pressure drop.



Battery power management

Optimal control of power consumption ensures long operation time and reduces the number of site visits. A customer-selectable "low battery" level setting with call up alarm lets you know when it's time to replace the battery.



Obstruction free

No moving parts make MAG 8000 resistant to solids and debris in the water.



Durable against flooding and high humidity



Durable against high – low temperature



Durable against corrosion

Intelligence to optimize water supply and consumption

MAG 8000 water meters have intelligent features built-in. With advanced display of information, on-site data collection and remote monitoring via communication networks, MAG 8000 makes sure you get all the information you need to optimize water supply and reduce consumption.

Data flows better with Siemens...

MAG 8000 open communication platform makes network integration easy. It can be integrated into your current system. And it is open for upgrading to communication network platforms of the future, eliminating the need to re-invest in new water meters, or making a step wise investment.

MAG 8000 performance enhancing features

- Consumption logging with up to 26 months of data
- Leakage detection program
- Consumption profile
- Meter utilization for meter selection
- Tariff and settling data for billing
- Advanced flow statistic
- Meter status and alarm handling
- Meter and application diagnostic
- Data protection and back up



Add-on communication

Communications module can be installed if network capability is required.



Easy access to data on-site

Standard IrDA interface for MAG 8000 configuration, data collection and documentation using Siemens Process Device Manager or Flow Tool Software.

"Information on the desk"

Siemens offers a complete wireless Automated Meter Reading solution. Data from the site can be directly accessed over the Internet using a standard browser and secure password protection.



Easy-to-read display

Graphical display and keypad for simple operation and instant access to information.

MAG 8000 provides intelligent information with an on-site display.



Meter information



Service



Data logger



Statistic



Revenue

SITRANS F MAG 8000 stands out when it comes to stand alone water applications

The MAG 8000 program provides a terrific combination of world-class performance, dedicated application solutions and water certifications. It offers powerful ways to optimize water supply and customer service.

- 1) Designed for stand-alone water applications and simple to install
- 2) Long lasting performance with superior measurement and minimal cost of ownership
- 3) Intelligent information, easy to access onsite or online using open, "future-proof" communications platform

Water certifications

MAG 8000 is approved to the international water meter standard OIML R49, complying to the European CEN – EN 14154 specifications.

Backed by Siemens

MAG 8000 is designed to exceed expectations and is backed by Siemens' exceptional international service and support.



The MAG 8000 program includes different versions to meet different market demands:

- Basic version for general water applications
- Advanced version for advanced information and functionality
- Custody Transfer version with pattern approval for water billing

MAG 8000 program delivers the performance, dependability and long life that make it the water industry's water meter of choice.

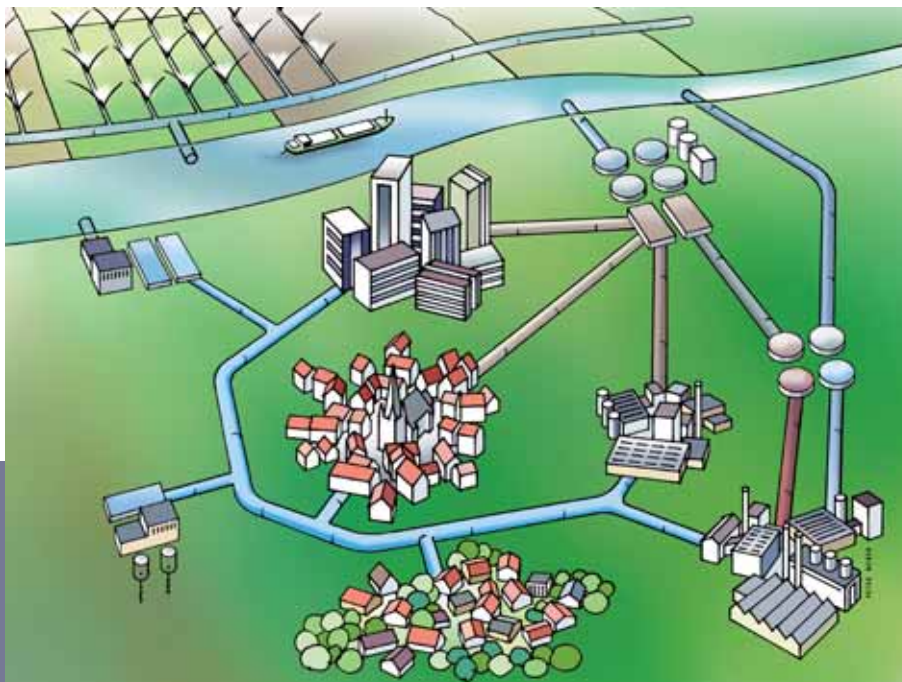

One water meter platform for water applications

- Abstraction – monitoring water collection and avoid draining
- Distribution network – optimize water supply and reduce leakage
- Revenue metering – provide correct billing and monitoring of consumption
- Irrigation – ensure long term performance for optimal ownership

Your Siemens partners worldwide

Find a contact in your area at:

www.siemens.com/processinstrumentation

www.siemens.com/flow

www.siemens.com/mag8000



Siemens Flow Instruments A/S
DK-6430 Nordborg
Denmark

www.siemens.com/processautomation

The information provided in this brochure contains merely general descriptions or characteristics of performance which in case of actual use do not always apply as described or which may change as a result of further development of the products. An obligation to provide the respective characteristics shall only exist if expressly agreed in the terms of contract.

All product designations may be trademarks or product names of Siemens AG or supplier companies whose use by third parties for their own purposes could violate the rights of the owners.